

# HARRY GWALA DISTRICT MUNICIPALITY



## UMZIMKHULU BULK SEWER

CONSTRUCTION OF UMZIMKHULU BULK SEWER OUTFALL

**CONTRACT No. HGDM 759/HGDM/2022**

**CIDB CONTRACTOR GRADING**  
**7CE OR Higher**

**COMPILED BY:**

Zimile Consulting Engineers  
76 Hope Street  
Kokstad  
4700

Tel N°: +27 39 940 6729  
Fax N°: N/A  
Email: info@zimile.co.za

**ON BEHALF OF:**

Harry Gwala District Municipality  
Private Bag X 501  
Ixopo  
3276

Tel N°: +27 39 834 8700  
Fax N°: +27 39 834 2259  
Email: GqibaD@harrygwaladm.gov.za

**FEBRUARY 2022**

NAME OF TENDERER	
ADDRESS OF TENDERER	
TELEPHONE	
FAX	
TENDER SUM	

**TENDER CLOSING DATE: 12H00, 03 MARCH 2022**

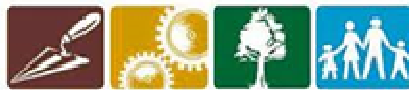

**EXPANDED PUBLIC WORKS PROGRAMME**  
Creating opportunities towards human fulfillment

**TENDER DOCUMENT CHECKLIST**

Tenderers must complete this document checklist to ensure that all information is completed in the Tender Document.

	<b>ITEMS</b>	<b>CHECKED Tenderer</b>
1)	Correct Tender Offer Amount carried forward to Cover Page and Form of Offer on Section C.1.....	<input type="checkbox"/>
2)	All pages requiring signatures signed by the Tenderer .....	<input type="checkbox"/>
3)	Bill of Quantities	
	i) Completed in <b>BLACK INK</b> only .....	<input type="checkbox"/>
	ii) Corrections crossed out and initialled.....	<input type="checkbox"/>
4)	Submission of All Returnable Documents and Schedules	
A	Authority for Signatory.....	<input type="checkbox"/>
B	MBD Forms.....	<input type="checkbox"/>
C	Schedule of work carried out by Tenderer.....	<input type="checkbox"/>
D	Amendments, Qualifications and Alternatives.....	<input type="checkbox"/>
E	Tax Clearance Certificate.....	<input type="checkbox"/>
F	Compulsory Enterprise Questionnaire.....	<input type="checkbox"/>
G	BBBEE Certificate.....	<input type="checkbox"/>
H	Key Personnel .....	<input type="checkbox"/>
I	Contractor's Health and Safety Declaration.....	<input type="checkbox"/>
5)	J Data to be provided by Tenderer.....	<input type="checkbox"/>

**UMZIMKHULU BULK SEWER****CONSTRUCTION OF UMZIMKHULU BULK SEWER OUTFALL****CONTRACT N<sup>o</sup> HGDM 759/HGDM/2022****TABLE OF CONTENTS**

<b>PART</b>	<b>DESCRIPTION</b>	<b>PAGE COLOUR</b>	<b>PAGE No.</b>
<b>PART T: THE TENDER</b>			<b>TP 1-TP25</b>
T1.1.	Tender Notice and Invitation to Tender	White	TP 2
T1.2	Tender Data	Pink	TP 4
T2.1	Returnable Documents and Schedules	Yellow	RD 1
T2.2	List of Returnable Documents and Schedules	Yellow	RD 2 to RD 57
<b>PART C1: AGREEMENTS AND CONTRACT DATA</b>			<b>C 1 to C 21</b>
C1.1	Form Offer and Acceptance	Yellow	C 2
C1.2	Contract Data	Yellow	C 7
C1.3	Performance Guarantee	Yellow	C 12
C1.4	Disclosure Statement	Yellow	C 15
C1.5	Agreement in terms of the Occupational Health and Safety Act No. 85 of 1993	Yellow	C 16
C1.6	Adjudication Board Member Agreement	Yellow	C18
<b>PART C2: PRICING DATA</b>			<b>PD 1 to PD 24</b>
C2.1	Pricing Instructions	Yellow	PD 2
C2.2	Schedule of Quantities	Yellow	PD 6
<b>PART C3: SCOPE OF WORK</b>			<b>SW 1 to SW 133</b>
	Scope of Work	Blue	SW 1
<b>PART C4: SITE INFORMATION</b>			<b>SI 1 to SI 4</b>
	Site Information	Green	SI 1
<b>PART C5: DRAWINGS</b>			<b>D1 – D 18</b>
	Drawings	Green	D1

HARRY GWALA DISTRICT MUNICIPALITY

CONSTRUCTION OF UMZIMKHULU BULK SEWER OUTFALL

HGDM 759/HGDM/2022

---

**PLANNING AND DESIGN OF UMZIMKHULU BULK SEWER**

**CONTRACT N° HGDM 759/HGDM/2022**

**CONSTRUCTION OF UMZIMKHULU BULK SEWER OUTFALL**

**PART T1: TENDERING PROCEDURES**

**TABLE OF CONTENTS**

T1.1: Tender Notice and Invitation to Tender.....	TP 2
T1.2: Tender Data .....	TP 4

**T1.1:Tender Notice and Invitation to Tender**



**HARRY GWALA DISTRICT MUNICIPALITY  
INFRASTRUCTURE SERVICES DEPARTMENT**

**BID NOTICE**

**BID INVITATION**

Bids are hereby invited, from qualified and experienced Bidders, for the construction of the following Infrastructure projects within the Harry Gwala District municipality

NO.	PROJECT NAME	CIDB GRADING	COMPULSORY BRIEFING DATE	TENDER NUMBER	CLOSING DATE
i.	<b>PLANNING AND DESIGN OF UMZIMKHULU BULK SEWER:  CONSTRUCTION OF UMZIMKHULU BULK SEWER OUTFALL</b>	<b>7CE OR HIGHER</b>	<b>14 February 2022 at 10:30am Bidders are to meet in Umzimkhulu Council Chamber then proceed to site</b>	<b>HGDM 759/HGDM/2022</b>	<b>03 MARCH 2022 at 12H00</b>

Only Bidders that have the required CIDB Grading listed on the table above will be considered. Joint Ventures are also eligible to submit Bids provided that every member of the Joint Venture is registered with the CIDB, and a combined grade of Joint Venture calculated in accordance with the CIDB regulations is equal to or higher than the specified Contractor grading.

**Invalid or non-submission of the following documents will lead to immediate disqualification.**

- Original Valid Tax Pin Certificate from SARS;
- Certified Copies of Company or CC Documents together with certified copies of member/s ID;
- JV Agreement (if applicable);
- A signed MBD4 form must be submitted with all bids (available on our website or at reception)

**The following will apply in all the above bids:**

- Valid tax pin certificate
- Price(s) quoted must be firm and must be inclusive of VAT;
- A firm delivery period must be indicated;
- All tenders must be valid for 90 days after the tender closing date

**HARRY GWALA DISTRICT MUNICIPALITY**

**CONSTRUCTION OF UMZIMKHULU BULK SEWER OUTFALL**

**HGDM 759/HGDM/2022**

---

- A certified and valid B-BBEE status level verification certificate or an original sworn affidavit for claiming preference points.
- 80/20 Preference point system will be used in Evaluation. Functionality will be calculated first.

**COLLECTION OF BID DOCUMENTS**

Bid documents may be collected from the **02 February 2022 between 09h00 to 16h00** at Harry Gwala District Municipality Offices, Finance Services Department, situated at Ixopo 40 Main Street, Ixopo 3276. Tender documents will be issued upon payment of a non-refundable cash fee of **R 1000 .00 each**.

**NB: No documents will be sold after briefing meetings.**

**CLOSING DATE**

The closing date for the bids is as per the table above. Bids must be enclosed in **SEALED ENVELOPES** and clearly labelled with the contract number and project name on the outside of the envelopes addressed to **The Municipal Manager**.

Bids must be deposited in the Bid Box at the reception area of Harry Gwala District Municipal, 40 Main Street, IXOPO before the closing date. Telegraphic, telexed or faxed bids will not be considered and late bids will not be accepted.

Harry Gwala District Municipality does not bind itself to accept the lowest or any Bid and reserves the right to accept the whole or any part of the bid.

**BID ENQUIRIES**

All bid enquiries and other matters shall be directed to: Executive Director: Water Services: Mr D S Gqiba during working hours on Tel.:039-834 2485

**Mrs NA. Dlamini**  
**Municipal Manager**

## T1.2: Tender Data

### GENERAL

The Conditions of Tender applicable to this contract are the Standard Conditions of Tender as contained in Annexure F of the CIDB *Standard for Uniformity in Construction Procurement, including the amendment made through Board Notice 136 Government Gazette No 38960 of 10 July 2015*. This document is obtainable separately. Tenderers shall obtain their own copies.

The Tender Data make several references to the Standard Conditions of Tender for details that apply specifically to this tender. The Tender Data shall have preference in the interpretation of any ambiguity or inconsistency between it and the Standard Conditions of Tender.

Each item of Tender Data given below is cross-referenced to the relevant clause in the Standard Conditions of Tender to which it mainly applies. The Tender Data shall have precedence in the interpretation of any ambiguity or inconsistency between it and the Standard Conditions of Tender. Each item of Tender Data given below is cross-referenced to the relevant clause in the Standard Conditions of Tender.

Clause Number	Description
<b>F.1</b>	<b>GENERAL</b>
<b>F.1.1</b>	<p><b>Actions</b> The Employer for this Contract is:</p> <p>Name : Harry Gwala District Municipality Contact Name : Mr Dumisani Gqiba Address : 40 Main Street Ixopo 3276 Private Bag X501, Ixopo 3276</p> <p>Tel : 039 834 8700 Fax : 039 834 2259 E-mail address : GqibaD@harrygwalam.gov.za</p>
<b>F.1.2</b>	<p><b>Tender Documents</b> (a) <b>The Tender Document</b>, issued by the Employer consists of the following:</p> <p><b>THE TENDER</b> <b>T1: Tendering Procedures</b> T1.1: Tender Notice and Invitation to Tender T1.2: Tender Data</p> <p><b>T2: Returnable Documents</b> T2.1: List of Returnable Documents T2.2: Returnable Schedules and Documents</p> <p><b>THE CONTRACT</b> <b>Part 1: Agreements and Contract Data</b> C1.1: Form of Offer and Acceptance C1.2: Pro-Forma Forms to be completed by successful tenderer only C1.3: Contract Data</p> <p><b>Part 2: Pricing Data</b> C2.1: Pricing Instructions C2.2: Bill of Quantities</p>

	<p><b>Part 3: Scope of Work</b> C3.1: Description of the Works C3.2: Engineering C3.3: Procurement C3.4: Construction Specifications</p> <p><b>Part 4: Site Information</b> C4.1: Locality Plan C4.2: Geotechnical</p> <p><b>Part 5: Annexures</b> C5.1: Construction Health &amp; Safety Specification C5.2: Environmental Management Plan C5.3: Contract Signboard</p> <p>(b) <b>The Drawings</b>, issued separately from this document</p> <p>The Tender Document and drawings shall be obtained from the Employer at the physical address stated in the Tender Notice, upon payment of the deposit stated in the Tender Notice.</p> <p>In addition, the following documents, which are obtainable separately, are also referred to and are deemed to form part of this tender.</p> <p>(c) <b>“General Conditions of Contract for Construction Works – 3rd Edition 2015”</b></p> <p>This document is issued by the South African Institution of Civil Engineering. (Short title “General Conditions of Contract 2015”), and is obtainable separately. Tenderers shall obtain their own copies.</p> <p>(d) <b>“Standardised Specifications for Civil Engineering Construction” SABS 1200</b></p> <p>This document is obtainable separately, and Tenderers shall obtain their own copies of the applicable sections.</p> <p>(e) <b>The Occupational Health and Safety Act N° 85 of 1993 and Amendment Act N° 181 of and the Construction Regulations 2014 (Government Gazette N° 37305 of 07 February 2014, Notice N° R84)</b></p> <p>This document is obtainable separately, and Tenderers shall obtain their own copies.</p> <p>(f) In addition, Tenderers are advised, in their own interest, to obtain their own copies of the following acts, regulations and standards referred to in this document as they are essential for the Tenderer to get acquainted with the basics of construction management, the implementation of preferential construction procurement policies and participation of targeted enterprise and labour.</p> <p>(i) The Construction Industry Development Board Act No 38 of 2000 and the Regulations in terms of the CIDB Act 38/2000, as at the closing time of this Tender,</p> <p>(ii) SANS 1921:2004 Construction and Management Part 1: General Engineering and Construction Works; Part 2: Accommodation of Traffic on Public Roads occupied by the Contractor; Part 6: HIV &amp; AIDS Awareness.</p> <p>(ii) SANS 10396:2003 Implementing Preferential Construction Procurement Policies using Targeted Procurement Procedures</p> <p>(iv) SANS 1914:2003 Targeted Construction Procurement, Parts 1 to 6, dealing with Participation of Targeted Enterprises, Joint Ventures, Targeted Labour, etc.</p>
--	---



**HARRY GWALA DISTRICT MUNICIPALITY**

**CONSTRUCTION OF UMZIMKHULU BULK SEWER OUTFALL**

**HGDM 759/HGDM/2022**

	(g) The Harry Gwala District Municipality Supply Chain Management Policy in terms of Section III of the Local Government Municipal Finance Management Act (Act N° 56 of 2003).
<b>Clause No.</b>	<b>Description</b>
<b>F.1.4</b>	<b>Communication and Employer's Agent</b> <b>The Employer's Agent's (also referred to as the Engineer) details are as follows:</b>
	<p>Name: Zimile Consulting Engineers                  Address: 76 Hope Street                  Kokstad                  4700</p> <p>Tel N°: +27 39 940 9729                  Fax N°: N/A</p> <p>Contact Person: Shawn Gama                  Email: <a href="mailto:info@zimile.co.za">info@zimile.co.za</a></p>
<b>F1.5</b>	<b>The Employers right to accept or reject any tender offer</b> The Employer is not obliged to accept the lowest or any tender offered
<b>F.2</b>	<b>TENDERER'S OBLIGATIONS</b>
<b>F.2.1</b>	<p><b>Eligibility</b></p> <p>A Tenderer will only be eligible to submit a tender if he/she meets all of the following criteria:</p> <p>(a) Only those Tenderers who are registered with the CIDB, in a contractor as stated in the Tender Notice and Invitation to Tender determined in accordance with Regulations 25 (1B) or 25 (7A) of the Construction Industry Development Regulations, are eligible to have their tenders evaluated</p> <p>See Returnable Documents T2.2.1 FORM A.</p> <p>(b) Joint ventures are eligible to submit tenders provided that:</p> <ol style="list-style-type: none"> <li>1. every member of the joint venture is registered with the CIDB</li> <li>2. the lead partner has a contractor grading designation in the class of construction work as specified in the Invitation to Tender.</li> <li>3. the combined contractor grading designation calculated in accordance with the Construction Industry Development Regulations is equal to or higher than the contractor grading designation required.</li> </ol> <p>(c) Only those tenderers who have in their employ management and supervisory staff satisfying the requirements of the scope of work for supervisory and management staff are eligible to submit tenders.</p> <p>(d) Tenderers are required to achieve the stipulated minimum thresholds, as per the relevant Treasury Instruction Note on local content and production. (See Returnable Documents T2.2.1 FORM J3)</p>

<p><b>F2.7</b></p>	<p><b>Site visit and clarification meeting</b>                  The arrangements for the compulsory clarification meeting and site inspection are as stated in the Tender Notice and Invitation to Tender.</p> <p>Enquiries regarding the visit (at least one full working day in advance) may be directed to:</p> <p><b>Contact Name: Mr Innocent Masunungure (Consultant)</b>  <b>Tel N°: 039 940 6729</b>  <b>Cellular N°: 078 965 0485</b></p>
<p><b>F.2.8</b></p>	<p><b>Seek clarification</b>                  Working days shall be defined as Monday to Friday Inclusive and shall exclude all gazetted public holidays.</p>
<p><b>F.2.11</b></p>	<p><b>Alterations to documents</b></p> <p>A Tender offer shall not be considered if alterations have been made to the offer or contract data (unless such alterations have been duly authenticated by the Tenderer) or if any particulars required therein have not been completed in all respects.</p> <p>Use of correction fluid is not permitted, and the presence of correction fluid in the tender shall render the tender submission invalid.</p>
<p><b>F2.12</b></p>	<p><b>Alternative tender offers</b>                  No Alternate Offers will be accepted</p>
<p><b>F.2.13</b></p>	<p><b>Submitting a Tender Offer</b></p>
<p>F.2.13.2</p>	<p>Tenderers to note that the returnable documents are listed in T.2 (Returnable Documents).</p>
<p>F.2.13.3</p>	<p>Under no circumstances whatsoever may the tender forms be retyped or redrafted. Tenderers are to note that no loose documents will be accepted. All returnable documents must be separately bound and labelled.</p> <p><i>Tender offers shall be submitted as an original with one (1) copy. Where an original or certified copy of a particular returnable document is required, these shall be included as originals or certified copies, as appropriate in both the “original” and the “copy” documents.</i></p> <p>The “Copy” document need not have copies of the entire document. Parts T2.2 (Returnable Schedules and Documents), C1.1 (Form of Offer and Acceptance), C1.2 (Contract Data) and C2.2 (Bill of Quantities) shall be submitted as the “Copy” document. Failure to submit a copy document will render the tender submission invalid.</p>

**HARRY GWALA DISTRICT MUNICIPALITY**

**CONSTRUCTION OF UMZIMKHULU BULK SEWER OUTFALL**

**HGDM 759/HGDM/2022**

F.2.13.5	<p>Delivery of Tender</p> <p>The Employer’s address for delivery of tender offers and identification details to be shown on each tender offer package are:</p> <p><b>Location of tender box : Harry Gwala District Municipality Building</b></p> <p><b>Physical address : 40 Main Street, Ixopo</b></p> <p><b>Identification details : Umzimkhulu Bulk Sewer Outfall HGDM 759/HGDM/2022</b></p> <p>Under no circumstances must documents be handed to an employee of Harry Gwala District Municipality or handed in at the Procurement Department. Tender documents sent via courier services must also be deposited in the Tender Box and not handed to an employee of Harry Gwala District Municipality</p> <p>Late tenders and tenders not in the tender box at the time of opening will not be accepted by the District Municipality and will be returned to the applicant unopened.</p> <p><b>NB: HGDM will not accept responsibility for tender documents which are not deposited in the Tender Box.</b></p>
F.2.13.6	A two-envelope procedure will NOT be followed. (Read with F.3.5 hereafter).
F.2.13.9	Telephonic, telegraphic, telex, facsimile or e-mailed tender offers will not be accepted.
F.2.15.1	<p><b>Closing Time</b></p> <p>The closing time for submission of Tender Offers is as stated in the Tender Notice and Invitation to Tender</p>
F.2.16.1	<p><b>Tender Offer Validity</b></p> <p>The Tender Offer validity period is <b>120 days</b> from the closing time for submission of tenders.</p>
F2.18	<p><b>Provide Other Material</b></p> <p>The tenderer shall, when requested by the Employer to do so, submit the names of all management and supervisory staff that will be employed together with satisfactory evidence that such staff members satisfy the eligibility criteria.</p>
F.2.19	<p><b>Inspections, tests, and analyses</b></p> <p>Access shall be provided for inspections and testing by personnel acting on behalf of the Employer, subject to prior arrangement.</p>
F.2.20	<p><b>Sureties, Bonds and Policies</b></p> <p>The Tenderer is required to submit with his Tender a letter of intent from an approved financial institution registered with the Financial Services Board undertaking to provide the PERFORMANCE GUARANTEE - DEMAND GUARANTEE to the format included in Part T2.2 of this procurement document.</p>
F.2.22	<p><b>Return of Tender Documents</b></p> <p>Where a tenderer who received a tender document does not submit a tender, the tender documents issued to him must be returned to the Employer within <b>35 days</b> after the closing</p>

	date for submission of tenders.												
<b>F.2.23</b>	<p><b>Certificates</b></p> <p>The tenderer shall submit with his tender:</p> <p>Certificates as called for in Section T2 – Returnable Documents. Proof of qualifications and other documentation required shall only be accepted on the basis of originals and certified copies of certificates and other documents.</p> <p>Certificates as required in the Returnable Schedules and Forms must be provided with the tender for each party to a consortium / joint venture.</p>												
<b>F.3</b>	<b>THE EMPLOYER’S UNDERTAKINGS</b>												
<b>F3.1</b>	<p><b>Respond to requests from the tenderer</b></p> <p>Working days shall be defined as Monday to Friday Inclusive and shall exclude all gazetted public holidays</p>												
<b>F.3.4</b>	<p><b>Opening of Tender Submissions</b></p> <p>Tenders will be opened immediately after closing time of tenders (see Tender Notice and Invitation to Tender) at the location of the tender box.</p>												
<b>F3.5</b>	<p><b>Two-envelope system</b></p> <p>The two-envelope system will NOT be followed for this contract.</p>												
<b>F3.8</b>	<p><b>Test for Responsiveness</b></p> <p>The minimum qualifying Functionality Evaluation Score shall be 65 (Sixty-five) points</p>												
<b>F.3.11</b>	<p><b>Evaluation of Tender Offers</b></p> <p>The procedure for the evaluation of responsive Tenders is Method 2 (Financial Offer and Preference)</p>												
<b>F3.11.3</b>	<p><b>Method 2: Functionality, Price and Preference</b></p> <p>The procedure for the evaluation of responsive Tenders is Method 2 (Functionality, Price and Preference). With the applicable preference point systems being:</p> <p>80/20 system for Tenders with a Rand value of less than R50 000 000.00, inclusive of VAT, in which 80 points are allocated for price and 20 points for preference in respect of all responsive Tenders received.</p>												
<b>F3.11.8</b>	<p><b>Scoring preferences</b></p> <p>Points for preference will be scored as set out in Returnable Documents T2.2.1 FORMS P &amp; Q (MBD 6.1). The tenderer is to complete this Section to claim points for B-BBEE Status Level.</p>												
<b>F3.11.9</b>	<p><b>Scoring Functionality</b></p> <p>The table below lists the returnable schedules that set out the scoring criteria and sub-criteria, and the percentage weighting for the score achieved against the relevant schedule:</p> <table border="1" style="margin-left: 40px;"> <thead> <tr> <th>Returnable Schedule</th> <th>Criteria</th> <th></th> <th></th> <th>Total Weighting %</th> </tr> </thead> <tbody> <tr> <td rowspan="2" style="text-align: center;"><b>Form D1</b></td> <td rowspan="2">Tenderer’s experience in supply and Installation of uPVC Sewer outfalls or</td> <td style="text-align: center;">No of Projects completed</td> <td style="text-align: center;">Points</td> <td rowspan="2" style="text-align: center;">18</td> </tr> <tr> <td style="text-align: center;">1 Project</td> <td style="text-align: center;">4</td> </tr> </tbody> </table>	Returnable Schedule	Criteria			Total Weighting %	<b>Form D1</b>	Tenderer’s experience in supply and Installation of uPVC Sewer outfalls or	No of Projects completed	Points	18	1 Project	4
Returnable Schedule	Criteria			Total Weighting %									
<b>Form D1</b>	Tenderer’s experience in supply and Installation of uPVC Sewer outfalls or	No of Projects completed	Points	18									
		1 Project	4										

HARRY GWALA DISTRICT MUNICIPALITY

CONSTRUCTION OF UMZIMKHULU BULK SEWER OUTFALL

HGDM 759/HGDM/2022

		Pipelines greater than 300mm NB and greater than 500m In length	2 Projects	8		
			3 Projects	13		
			4 Projects	18		
	<b>Form D2</b>	Tenderer's experience in Refurbishment of existing sewers or pipe diameters equal to or greater than 160mm		No of Projects completed	Points	15
				1 Project	3	
				2 Projects	8	
				3 Projects	12	
	<b>Form D3</b>	Tenderer's Experience In Trenchless Construction technology (Pipe Jacking)		No of Projects completed	Points	20
				1 Project	5	
				2 Projects	10	
				3 Projects	15	
	<b>Form D4</b>	Tenderer's experience in the Construction of Reinforced Concrete Structures 6m or higher		No of Projects completed	Points	21
				1 Project	5	
				2 Projects	10	
				3 Projects	15	
	<b>Form H</b>	Financial Resources		Bank Rating	Points	5
				Rating A	5	
				Rating B		
				Rating C		
	<b>Form T</b>	Experience of Key Personnel		Rating D	0	
				Rating E		
Rating F						
Rating G						
<b>Form Y</b>	Quality Assurance Plan and Control Procedures		Rating H	0		
			Rating G			
			Rating F			
			Rating E			
<b>Form T</b>	Experience of Key Personnel		Key Personnel	Experience	16	
			Contracts Manager: Relevant Professional Registration with ECSA or SACPCMP with more than 5 years' appropriate experience	2		
			Construction Manager / Site Agent: Relevant Professional Registration with ECSA or SACPCMP with more than 8 years' of appropriate experience	6		
			Structural Foreman: With more than 10 years' appropriate experience	6		
			Pipe Laying Foreman: With more than 8 years' appropriate experience	2		
<b>Form Y</b>	Quality Assurance Plan and Control Procedures		Score Status	Points	5	
			Have ISO 9001 Accreditation	5		
			Have Own Internal QA Plan	3		
			None	0		
	<b>Total Possible Points</b>				<b>100</b>	

Failure to score a single point in any of the criteria listed above will deem the bid to be non-responsive and the bidder will be disqualified. Additionally, a score of less than that stipulated in F.3.8 will deem the bid to be non-responsive and the bidder will be disqualified

The score allocated by each Bid Evaluation Committee member for a tender shall be the sum, of the scores relevant to each of the above listed returnable schedules multiplied by the percentage weighting for each as shown above.

<p><b>F3.13</b></p>	<p><b>Acceptance of Tender Offer</b></p>
<p>F.3.13.1</p>	<p>Tender Offers will only be accepted if, in addition to the conditions listed in the Standard Conditions of Tender;</p> <p>(a) The Tenderer has purchased the tender documents as stated in the Tender Advertisement and Notice to Tenderers.</p> <p><i>See Returnable Documents T2.1 FORM L.</i></p> <p>(b) The Tenderer has attended the compulsory briefing meeting.</p> <p><i>See Returnable Documents T2.1 FORM A.</i></p> <p>(c) The tenderer has the legal capacity to enter into the Contract and the signatory to the tender has the legal capacity to sign the tender.</p> <p><i>See Returnable Documents T2.1 FORMS B.</i></p> <p>(d) The Tenderer is in good standing financially, and is not</p> <ul style="list-style-type: none"> <li>• Insolvent</li> <li>• in receivership</li> <li>• bankrupt</li> <li>• being wound up</li> <li>• having his affairs administered by a court or a judicial officer</li> <li>• suspending his business activities</li> <li>• subject to legal proceedings in respect of the foregoing.</li> </ul> <p>Tenderers are required to submit a Bank Rating with this tender.</p> <p><i>See Returnable Documents T2.1 FORMS H.</i></p> <p>(e) The Tenderer can provide proof that he/she is in good standing with respect to duties, taxes, levies and contributions required in terms of legislation applicable to the work in the contract.</p> <p><i>See Returnable Documents T2.1 FORM G</i></p> <p>(f) The Tenderer can demonstrate that he/she possesses the necessary professional and technical qualifications and competent, financial resources, equipment and other physical facilities, managerial capability, personnel, experience and reputation to perform the contract;</p> <p><i>See Returnable Documents T2.1 FORMS T, Q and R</i></p> <p>(g) The Tenderer or any of its principals, directors or managers is not employed in the service of the State or any municipality. In the event that such principals are involved, official approval from the Executing Authority regarding carrying out remunerative work outside of the public service must be included in the tender submission.</p> <p>The tenderer must completed the Declaration of Interest and the Compulsory Enterprise Questionnaire and there are no conflicts of interest which may impact on the tenderer's ability to perform the contract in the best interests of the employer or potentially compromise the tender process.</p>

	<p><i>See Returnable Documents T2.1 FORMS N &amp; J.</i></p> <p>(h) The Tenderer must demonstrate that he/she is able to arrange an acceptable performance guarantee should he/she be awarded the contract.</p> <p><i>See Returnable Documents T2.1 FORM I and Performance Guarantee Section C1.3.</i></p> <p>(i) The Tenderer must confirm that he/she has the necessary competencies and resources to carry out the work safely in accordance with the Occupational Health and Safety Act, N° 85 of 1993, and the OSHA 1993 Construction Regulations 2014.</p> <p><i>See Returnable Documents T2.1 FORM V</i></p> <p>(j) The Tenderer and his principals are not under any restriction to participate in the Employers procurement due to corrupt or fraudulent practices.</p> <p><i>See Returnable Documents T2.1 FORM N</i></p> <p>(k) The tenderer is up to date with the payment of their Municipal Accounts and Rates.</p> <p><i>See Returnable Documents T.2.1 FORM X.</i></p> <p>(l) The tenderer or any of its directors/shareholders is not listed on the Register of Tender Defaulters in terms of the Prevention and Combating of Corrupt Activities Act of 2004 as a person prohibited from doing business with the public sector.</p> <p>(m) The Tenderer has not abused the Employer’s Supply Chain Management System and has not been given a written notice to the effect that he has failed to perform on any previous contract.</p> <p>(n) The Employer is satisfied that the Tenderer or any of his principals have not influenced the tender offer and acceptance by the following criteria:</p> <ul style="list-style-type: none"> <li>○ having offered, promised or given a bribe or other gift or remuneration to any person in connection with the obtaining or execution of this contract;</li> <li>○ having acted in a fraudulent or corrupt manner in obtaining or executing this contract;</li> <li>○ having approached an officer or employee of the Employer or the employer’s Agent with the objective of influencing the award of a contract in the Tenderer’s favour;</li> <li>○ having entered into any agreement or arrangement, whether legally or not, with any other person, firm or company to refrain from tendering for this contract or as to the amount of the Tender to be submitted by either party;</li> <li>○ having disclosed to any other person, firm or company other than the Employer, the exact or approximate amount of his proposed Tender;</li> </ul> <p>The Employer may, in addition to using any other legal remedies, repudiate the Tender offer and acceptance and declare the Contract invalid should it have been concluded already.</p> <p>The Employer does not bind itself to accept the lowest or any tender.</p>
<p><b>F.3.17</b></p>	<p><b>Provide Copies of the Contract</b>                  The number of paper copies of the signed contract to be provided by the Employer is: <b>one</b>.</p>

**HARRY GWALA DISTRICT MUNICIPALITY**

**CONSTRUCTION OF UMZIMKHULU BULK SEWER OUTFALL**

**HGDM 759/HGDM/2022**

<b>F3.20</b>	<b>Mandatory Sub-Contracting.</b> The successful tenderer will be required to subcontract a portion of the works to designated groups as per the contract data.
--------------	--



**APPENDIX: STANDARD CONDITIONS OF TENDER**

*(These Standard Conditions of Tender have been reproduced, without any changes, from Appendix A of the CIDB Standardized Construction Procurement Documentation for Engineering Construction Works (5 August 2005))*

**F.1 General**

**F.1.1 Actions**

**F1.1.1.** The employer and each tenderer submitting a tender offer shall comply with these conditions of tender. In their dealings with each other, they shall discharge their duties and obligations as set out in F.2 and F.3, timeously and with integrity, and behave equitably, honestly and transparently, comply with all legal obligations and not engage in anticompetitive practices.

**F1.1.2.** The employer and the tenderer and all their agents and employees involved in the tender process shall avoid conflicts of interest and where a conflict of interest is perceived or known, declare any such interest in their tender submissions. Employees, agents and advisors of the employer shall declare any conflict of interest to whoever is responsible for overseeing the procurement process at the start of any deliberations relating to the procurement process or as soon as they become aware of such conflict, and abstain from any decisions where such conflict exists or recuse themselves from the procurement process, as appropriate.

Note 1) A conflict of interest may arise due to a conflict of roles which might provide an incentive for improper acts in some circumstances. A conflict of interest can create an appearance of impropriety that can undermine confidence in the ability of the person to act properly in his or her position even if no improper acts result.

2) Conflicts of interest in respect of those engaged in the procurement process include direct, indirect or family interests in the tender or outcome of the procurement process and any personal bias, inclination, obligation, allegiance or loyalty which would in any way affect any decision taken.

**F.1.1.3** The employer shall not seek, and a tenderer shall not submit a tender without having a firm intention and the capacity to proceed with the contract.

**F.1.2 Tender Documents**

The documents issued by the employer for the purpose of a tender offer are listed in the tender data.

**F.1.3 Interpretation**

**F.1.3.1** The tender data and additional requirements contained in the tender schedules that are included in the returnable documents are deemed to be part of these conditions of tender.

**F.1.3.2** These conditions of tender, the tender data and tender schedules which are only required for tender evaluation purposes, shall not form part of any contract arising from the invitation to tender.

**F.1.3.3** For the purposes of these conditions for the calling for expressions of interest, the following definitions apply:

(a) **conflict of interest** means any situation in which

i) someone in a position of trust has competing professional or personal interest which make it difficult to fulfil his or her duties impartially;

- ii) an individual or organisation is in a position to exploit a professional or official capacity in some way for their personal or corporate benefit; or
  - iii) incompatibility or contradictory interests exist between an employee and the organisation which employs that employee.
- (b) **comparative offer** means the tenderer's financial offer after the factors of non-firm prices, all unconditional discounts and any other tendered parameters that will affect the value of the financial offer have been taken into consideration
- (c) **corrupt practice** means the offering, giving, receiving or soliciting of anything of value to influence the action of the employer or his staff or agents in the tender process; and
- (d) **fraudulent practice** means the misrepresentation of the facts in order to influence the tender process or the award of a contract arising from a tender offer to the detriment of the employer, including collusive practices intended to establish prices at artificial levels
- (e) **Organisation** means a company, firm, enterprise, association or other legal entity, whether incorporated or not, or a public body
- (f) **Quality (functionality)** means the totality of features and characteristics of a product or service that bear on its ability to satisfy stated or implied needs.

#### F.1.4 Communication and employer's agent

Each communication between the employer and a tenderer shall be to or from the employer's agent only, and in a form that can be read, copied and recorded. Writing shall be in the English language. The employer shall not take any responsibility for non-receipt of communications from or by a tenderer. The name and contact details of the employer's agent are stated in the tender data.

#### F.1.5 The employer's right to accept or reject any tender offer

**F.1.5.1** The employer may accept or reject any variation, deviation, tender offer, or alternative tender offer, and may cancel the tender process and reject all tender offers at any time before the formation of a contract. The employer shall not accept or incur any liability to a tenderer for such cancellation and rejection but will give reasons for such action upon written request to do so.

**F.1.5.2** The employer may not be subsequent to the cancellation or abandonment of a tender process or the rejection of all tender offers re-issue a tender covering substantially the same scope of work within a period of six months unless only one tender was received, and such tender was returned unopened to the tenderer.

#### F.1.6 Procurement Procedures

##### F.1.6.1 General

Unless otherwise stated in the tender data, a contract will, subject F.3.13, be concluded with the tenderer who in terms of F.3.11 is the highest ranked or the tenderer scoring the highest number of tender evaluation points, as relevant, based on the tender submissions that are received at the closing time for tenders.

### **F.1.6.2 Competitive Negotiation Procedure**

**F.1.6.2.1** Where the tender data require that the competitive negotiation procedure is to be followed, tenderers shall submit tender offers in response to the proposed contract in the first round of submissions. Notwithstanding the requirements of F.3.4, the Employer shall announce only the names of the tenderers who make a submission. The requirements of F.3.8 relating to the material deviations or qualifications which affect the competitive positions of tenderers shall not apply.

**F.1.6.2.2** All responsive tenderers, or not less than three responsive tenderers that are highest ranked in terms of the evaluation method and evaluation criteria stated in the data, shall be invited in each round to enter the competitive negotiations, based on the principle of equal treatment, and keeping confidential the proposed solutions and associated information. Notwithstanding the provisions of F.2.17, the Employer may request that tenders be clarified, specified, and fine-tuned in order to improve a tenderer's competitive position provided that such clarification, specification, fine-tuning and additional information does not alter any fundamental aspects of the offers or impose substantial new requirements which restrict or distort competition or have a discriminatory effect.

**F.1.6.2.3** At the conclusion of each round of negotiations, tenderers shall be invited by the Employer to make a fresh tender offer, based on the same evaluation criteria, with or without adjusted weightings. Tenderers shall be advised when they are to submit their best and final offer.

**F.1.6.2.4** The contract shall be awarded in accordance with the provisions of F.3.11 and F.3.13 after tenderers have been requested to submit their best and final offer.

### **F.1.6.3 Proposal Procedure using two stage system**

#### **F.1.6.3.1 Option 1**

Tenderers shall in the first stage submit technical proposals and, if required, cost parameters around which a contract may be negotiated. The Employer shall evaluate each responsive submission in terms of the method of evaluation stated in the tender data, and in the second stage negotiate a contract with the tenderer scoring the highest number of evaluation points and award the contract in terms of these conditions of tender.

#### **F.1.6.3.2 Option 2**

**F.1.6.3.2.1** Tenderers shall submit in the first stage only technical proposals. The Employer shall invite all responsive tenderers to submit tender offers in the second stage, following the issuing of procurement documents.

**F.1.6.3.2.2.** The Employer shall evaluate tenders received during the second stage in terms of the method of evaluation stated in the tender data and award the contract in terms of these conditions of tender.

## **F.2 Tenderer's obligations**

### **F.2.1 Eligibility**

**F.2.1.1** Submit a tender offer only if the tenderer complies with the criteria stated in the tender data and the tenderer, or any of his principals, is not under any restriction to do business with employer.

**F.2.1.2** Notify the Employer of any proposed material change in the capabilities or formation of the tendering entity (or both) or any other criteria which formed part of the qualifying requirements used by the Employer as the basis in a prior process to invite the tenderer to submit a tender offer and obtain the Employer's written approval prior to do so prior to the closing time of tenders.

**F.2.2 Cost of tendering**

Accept that the employer will not compensate the tenderer for any costs incurred in the preparation and submission of a tender offer, including the costs of any testing necessary to demonstrate that aspects of the offer satisfy requirements.

**F.2.3 Check documents**

Check the tender documents on receipt for completeness and notify the employer of any discrepancy or omission.

**F.2.4 Confidentiality and copyright of documents**

Treat as confidential all matters arising in connection with the tender. Use and copy the documents issued by the employer only for the purpose of preparing and submitting a tender offer in response to the invitation.

**F.2.5 Reference documents**

Obtain, as necessary for submitting a tender offer, copies of the latest versions of standards, specifications, conditions of contract and other publications, which are not attached but which are incorporated into the tender documents by reference.

**F.2.6 Acknowledge addenda**

Acknowledge receipt of addenda to the tender documents, which the employer may issue, and if necessary, apply for an extension to the closing time stated in the tender data, in order to take the addenda into account.

**F.2.7 Site visit and clarification meeting**

Attend, where required, a site visit and clarification meeting at which tenderers may familiarize themselves with aspects of the proposed work, services or supply and raise questions. Details of the meeting(s) are stated in the tender data.

**F.2.8 Seek clarification**

Request clarification of the tender documents, if necessary, by notifying the employer at least five working days before the closing time stated in the tender data.

**F.2.9 Insurance**

Be aware that the extent of insurance to be provided by the employer (if any) may not be for the full cover required in terms of the conditions of contract identified in the contract data. The tenderer is advised to seek qualified advice regarding insurance.

**F.2.10 Pricing the tender offer**

- F.2.10.1** Include in the rates, prices, and the tendered total of the prices (if any) all duties, taxes (except Value Added Tax (VAT), and other levies payable by the successful tenderer, such duties, taxes and levies being those applicable 14 days before the closing time stated in the tender data.
- F.2.10.2** Show VAT payable by the employer separately as an addition to the tendered total of the prices.
- F.2.10.3** Provide rates and prices that are fixed for the duration of the contract and not subject to adjustment except as provided for in the conditions of contract identified in the contract data.
- F.2.10.4** State the rates and prices in Rand unless instructed otherwise in the tender data. The conditions of contract identified in the contract data may provide for part payment in other currencies.

**F.2.11 Alterations to documents**

Not make any alterations or additions to the tender documents, except to comply with instructions issued by the employer, or necessary to correct errors made by the tenderer. All signatories to the tender offer shall initial all such alterations. Erasures and the use of masking fluid are prohibited.

**F.2.12 Alternative tender offers**

- F.2.12.1** Unless otherwise stated in the tender data, submit alternative tender offers only if a main tender offer, strictly in accordance with all the requirements of the tender documents, is also submitted. The alternative tender offer is to be submitted with the main tender offer together with a schedule that compares the requirements of the tender documents with the alternative requirements the tenderer proposes.
- F.2.12.2** Accept that an alternative tender offer may be based only on the criteria stated in the tender data or criteria otherwise acceptable to the employer.

**F.2.13 Submitting a tender offer**

- F.2.13.1** Submit one tender offer only, either as a single tendering entity or as a member in joint venture, to provide the whole of the works, services or supply identified in the contract data, unless stated otherwise in the tender data.
- F.2.13.2** Return all returnable documents to the employer after completing them in their entirety, either electronically (if they were issued in electronic format) or by writing in black ink.
- F.2.13.3** Submit the parts of the tender offer communicated on paper as an original plus the number of copies stated in the tender data, with an English translation of any documentation in a language other than English, and the parts communicated electronically in the same format as they were issued by the employer.
- F.2.13.4** Sign the original and all copies of the tender offer where required in terms of the tender data. The employer will hold all authorized signatories liable on behalf of the tenderer. Signatories for tenderers proposing to contract as joint ventures shall state which of the signatories is the lead partner whom the employer shall hold liable for the purpose of the tender offer.

HGDM 759/HGDM/2022

- F.2.13.5** Seal the original and each copy of the tender offer as separate packages marking the packages as "ORIGINAL" and "COPY". Each package shall state on the outside the employer's address and identification details stated in the tender data, as well as the tenderer's name and contact address.
- F.2.13.6** Where a two-envelope system is required in terms of the tender data, place and seal the returnable documents listed in the tender data in an envelope marked "financial proposal" and place the remaining returnable documents in an envelope marked "technical proposal". Each envelope shall state on the outside the employer's address and identification details stated in the tender data, as well as the tenderer's name and contact address.
- F.2.13.7** Seal the original tender offer and copy packages together in an outer package that states on the outside only the employer's address and identification details as stated in the tender data.
- F.2.13.8** Accept that the employer shall not assume any responsibility for the misplacement or premature opening of the tender offer if the outer package is not sealed and marked as stated.
- F.2.13.9** Accept that tender offers submitted by facsimile or email will be rejected by the Employer, unless stated otherwise in the tender data.
- F.2.14** **Information and data to be completed in all respects**
- Accept that tender offers, which do not provide all the data or information requested completely and in the form required, may be regarded by the employer as non-responsive.
- F.2.15** **Closing time**
- F.2.15.1** Ensure that the employer receives the tender offer at the address specified in the tender data not later than the closing time stated in the tender data. Proof of posting shall not be accepted as proof of delivery. The employer shall not accept tender offers submitted by telegraph, telex, facsimile or e-mail, unless stated otherwise in the tender data.
- F.2.15.2** Accept that, if the employer extends the closing time stated in the tender data for any reason, the requirements of these conditions of tender apply equally to the extended deadline.
- F.2.16** **Tender offer validity**
- F.2.16.1** Hold the tender offer(s) valid for acceptance by the employer at any time during the validity period stated in the tender data after the closing time stated in the tender data.
- F.2.16.2** If requested by the employer, consider extending the validity period stated in the tender data for an agreed additional period.
- F.2.16.3** Accept that a tender submission that has been submitted to the employer may only be withdrawn or substituted by giving the employer's agent written notice before the closing time for tenders that a tender is to be withdrawn or substituted.
- F.2.16.4** Where a tender submission is to be substituted, submit a substitute tender in accordance with the requirements of F.2.13 with the packages clearly marked as "SUBSTITUTE".

**F.2.17 Clarification of tender offer after submission**

Provide clarification of a tender offer in response to a request to do so from the employer during the evaluation of tender offers. This may include providing a breakdown of rates or prices and correction of arithmetical errors by the adjustment of certain rates or item prices (or both). No change in the competitive position of tenderers or substance of the tender offer is sought, offered or permitted.

**F.2.18 Provide other material**

**F.2.18.1** Provide, on request by the employer, any other material that has a bearing on the tender offer, the tenderer's commercial position (including notarized joint venture agreements), preferencing arrangements, or samples of materials, considered necessary by the employer for the purpose of a full and fair risk assessment. Should the tenderer not provide the material, or a satisfactory reason as to why it cannot be provided, by the time for submission stated in the employer's request, the employer may regard the tender offer as non-responsive.

**F.2.18.2** Dispose of samples of materials provided for evaluation by the employer, where required.

**F.2.19 Inspections, tests, and analysis**

Provide access during working hours to premises for inspections, tests and analysis as provided for in the tender data.

**F.2.20 Submit securities, bonds, policies, etc.**

If requested, submit for the employer's acceptance before formation of the contract, all securities, bonds, guarantees, policies, and certificates of insurance required in terms of the conditions of contract identified in the contract data.

**F.2.21 Check final draft**

Check the final draft of the contract provided by the employer within the time available for the employer to issue the contract.

**F.2.22 Return of other tender documents**

If so, instructed by the employer, return all retained tender documents within 28 days after the expiry of the validity period stated in the tender data.

**F.2.23 Certificates**

Include in the tender submission or provide the employer with any certificates as stated in the tender data.

**F.3 The employer's undertakings**

**F.3.1 Respond to requests from the tenderer**

**F.3.1.1** Respond to a request for clarification received up to five working days prior to the tender closing time stated in the Tender Data and notify all tenderers who drew procurement documents.

**F.3.1.2** Consider any request to make material change in the capabilities or formation of the tendering entity (or both) or any other criteria which formed part of the qualifying requirements used to prequalify a tenderer to submit a tender offer in terms of a previous procurement process and deny any such request if as a consequence:

- a) An individual firm, or joint venture as a whole, or any individual member of the joint venture fails to meet any of the collective or individual qualifying requirements.
- b) The new partners to a joint venture were not prequalified in the first instance, either as individual firms or as another joint venture; or
- c) In the opinion of the Employer, acceptance of the material change would compromise the prequalification process.

### **F.3.2 Issue Addenda**

If necessary, issue addenda that may amend or amplify the tender documents to each tenderer during the period from the date of the Tender Notice until seven days before the tender closing time stated in the Tender Data. If, as a result a tenderer applies for an extension to the closing time stated in the Tender Data, the Employer may grant such extension and, will then notify it to all tenderers who drew documents.

### **F.3.3 Return late tender offers**

Return tender offers received after the closing time stated in the Tender Data, unopened, (unless it is necessary to open a tender submission to obtain a forwarding address), to the tenderer concerned.

### **F.3.4 Opening of tender submissions**

**F.3.4.1** Unless the two-envelope system is to be followed, open valid tender submissions in the presence of tenderers' agents who choose to attend at the time and place stated in the tender data. Tender submissions for which acceptable reasons for withdrawal have been submitted will not be opened.

**F.3.4.2** Announce at the opening held immediately after the opening of tender submissions, at a venue indicated in the tender data, the name of each tenderer whose tender offer is opened, the total of his prices, preferences claimed and time for completion, if any, for the main tender offer only.

**F.3.4.3** Make available the record outlined in F.3.4.2 to all interested persons upon request.

### **F.3.5 Two-envelope system**

**F.3.5.1** Where stated in the tender data that a two-envelope system is to be followed, open only the technical proposal of valid tenders in the presence of tenderers' agents who choose to attend at the time and place stated in the tender data and announce the name of each tenderer whose technical proposal is opened.

**F.3.5.2** Evaluate the quality of the technical proposals offered by tenderers, then advise tenderers who remain in contention for the award of the contract of the time and place when the financial proposals will be opened. Open only the financial proposals of tenderers, who score in the quality evaluation above the minimum number of points for quality stated in the tender data, and announce the score obtained for the technical proposals and the total price and any preferences claimed. Return unopened financial proposals to tenderers whose technical proposals failed to achieve the minimum number of points for quality.

### **F.3.6 Non-disclosure**

Not disclose to tenderers, or to any other person not officially concerned with such processes, information relating to the evaluation and comparison of tender offers, the final evaluation price, and recommendations for the award of a contract, until after the award of the contract to the successful tenderer.



**F.3.7 Grounds for rejection and disqualification**

Determine whether there has been any effort by a tenderer to influence the processing of tender offers and instantly disqualify a tenderer (and his tender offer) if it is established that he engaged in corrupt or fraudulent practices.

**F.3.8 Test for responsiveness**

**F.3.8.1** Determine, on opening and before detailed evaluation, whether each tender offer properly received:

- (a) meets the requirements of these Conditions of Tender,
- (b) has been properly and fully completed and signed, and
- (c) is responsive to the other requirements of the tender documents.

**F.3.8.2** A responsive tender is one that conforms to all the terms, conditions, and specifications of the tender documents without material deviation or qualification. A material deviation or qualification is one which, in the Employer's opinion, would:

- detrimentally affect the scope, quality, or performance of the works, services or supply identified in the Scope of Work,
- change the Employer's or the tenderer's risks and responsibilities under the contract, or
- affect the competitive position of other tenderers presenting responsive tenders, if it were to be rectified.

Reject a non-responsive tender offer, and not allow it to be subsequently made responsive by correction or withdrawal of the non-conforming deviation or reservation.

**F.3.9 Arithmetical errors**

**F.3.9.1** Check responsive tender offers for arithmetical errors between amounts in words and amounts in figures. Where there is a discrepancy between the amounts in figures and in words, the amount in words shall govern.

**F.3.9.2** Check the highest ranked tender or tenderer with the highest number of tender evaluation points after the evaluation of tenders in accordance with F.3.11 for:

- a) The gross misplacement of the decimal point in the unit rate,
- b) Omissions made in completing the pricing schedule or bills of quantities or
- c) Arithmetic errors in
  - Line-item totals resulting from the product of unit rate and a quantity in bills of quantities or schedule of prices; or
  - The summation of the prices.

**F3.9.2** Notify the tenderers of all errors or omissions that are identified in the tender offer and invite the tenderer to either confirm the tender offer as tendered or accept the corrected total of prices.

**F.3.9.3** Where the tenderer elects to confirm the tender offer as tendered, correct the errors as follows:

- a) If bills of quantities or pricing schedules apply and there is an error in the line-item total resulting from the product of the unit rate and the quantity, the line-item total as quoted shall govern, and the unit rate will be corrected. Where there is an obviously gross misplacement of the decimal point in the unit rate, the line-item total as quoted shall govern and the unit rate shall be corrected.

- b) Where there is an error in the total of the prices either as a result of other corrections required by this checking process or in the tenderer's addition of prices, the total of the prices shall govern, and the tenderer will be asked to revise selected item prices (and their rates if a bill of quantities applies) to achieve the tendered total of the prices.

Consider the rejection of a tender offer if the tenderer does not correct or accept the correction of his arithmetical errors in the manner described above.

### F.3.10 Clarification of a tender offer

Obtain clarification from a tenderer on any matter that could give rise to ambiguity in a contract arising from the tender offer.

### F.3.11 Evaluation of tender offers

#### F3.11.1 General

Appoint an evaluation panel of not less than three persons. Reduce each responsive tender offer to a comparative offer and evaluate them using the tender evaluation methods and associated evaluation criteria and weightings that are specified in the tender data.

#### F.3.11.2 Method 1: Price and Preference

In the case of a price and preference:

- 1) Score tender evaluation points for price
- 2) Score points for BBBEE contribution
- 3) Add the points scored for price and BBBEE.

#### F.3.11.3 Method 2: Functionality, Price and Preference

In the case of a functionality, price and preference:

- 1) Score functionality, rejecting all tender offers that fail to achieve the minimum number of points for functionality as stated in the Tender Data.
- 2) No tender must be regarded as an acceptable tender if it fails to achieve the minimum qualifying score for functionality as indicated in the tender invitation.
- 3) Tenders that have achieved the minimum qualification score for functionality must be evaluated further in terms of the preference points system prescribed in paragraphs 4 and 4 and 5 below.

The 80/20 preference point system for acquisition of services, works or goods up to Rand value of R50 million

- 4) (a)(i) The following formula must be used to calculate the points for price in respect of tenders (including price quotation) with a rand value equal to, or above R 30 000 and up to Rand value of R 50 000 000 (all applicable taxes included):

$$P_s = 80 \left( 1 - \frac{(P_t - P_{\min})}{P_{\min}} \right)$$

Where

$P_s$  = Points scored for comparative price of tender or offer under consideration.

$P_t$  = Comparative price of tender or offer under consideration; and

$P_{\min}$  = Comparative price of lowest acceptable tender or offer.

- (4)(a)(ii) An employer of state may apply the formula in paragraph (i) for price quotations with a value less than R30 000, if and when appropriate:

(4)(b) Subject to subparagraph(4)(c), points must be awarded to a tender for attaining the B-BBEE status level of contributor in accordance with the table below:

<b>B-BBEE status level of contributor</b>	<b>Number of points</b>
1	20
2	18
3	16
4	12
5	8
6	6
7	4
8	2
Non-compliant contributor	0

(4)(c) A maximum of 20 points may be allocated in accordance with subparagraph (4)(b)

(4)(d) The points scored by tender in respect of B-BBEE contribution contemplated in contemplated in subparagraph (4) (b) must be added to the points scored for price as calculated in accordance with subparagraph (4)(a).

(4)(e) Subject to paragraph 4.3.8 the contract must be awarded to the tender who scores the highest total number of points.

The 90/ 10 preference points system for acquisition of services, works or goods with a Rand value above R 50 million

(5)(a) The following formula must be used to calculate the points for price in respect of tenders with a Rand value above R50 000 000 (all applicable taxes included):

**90/10**

$$P_s = 90 \left( 1 - \frac{P_t - P_{\min}}{P_{\min}} \right)$$

*Where:*

*P<sub>s</sub> = Points scored for comparative price of tender or offer under consideration;*

*P<sub>t</sub> = Comparative price of tender or offer under consideration; and*

*P<sub>min</sub> = Comparative price of lowest acceptable tender or offer.*

(5)(b) Subject to subparagraph(5)(c), points must be awarded to a tender for attaining the B- BBEE status level of contributor in accordance with the table below:

B-BBEE status level of contributor	Number of points
1	10
2	9
3	8
4	5
5	4
6	3
7	2
8	1
Non-compliant contributor	0

- (5)(c) A maximum of 10 points may be allocated in accordance with subparagraph
- (5)(d) The points scored by tender in respect of B-BBEE contribution contemplated in subparagraph (5) (b) must be added to the points scored for price as calculated in accordance with subparagraph (5)(a).
- (5)(e) Subject to paragraph 4.3.8 the contract must be awarded to the tender who scores the highest total number of points.

#### F.3.11.6 Decimal places

Score price, preference and functionality, as relevant, to two decimal places.

#### F.3.11.7 Scoring Price

Score price of remaining responsive tender offers using the following formula:

$$N_{FO} = W_1 \times A$$

where:

$N_{FO}$  is the number of tender evaluation points awarded for price.

$W_1$  is the maximum possible number of tender evaluation points awarded for price as stated in the Tender Data.

$A$  is a number calculated using the formula and option described in Table F.1 as stated in the Tender Data.

Table F.1: Formulae for calculating the value of A

Formula	Comparison aimed at achieving	Option 1 <sup>a</sup>	Option 2 <sup>a</sup>
1	Highest price or discount	$A = (1 + (P - P_m)) P_m$	$A = P / P_m$
2	Lowest price or percentage commission / fee	$A = (1 - (P - P_m)) P_m$	$A = P_m / P$
<sup>a</sup> $P_m$ is the comparative offer of the most favourable comparative offer. $P$ is the comparative offer of the tender offer under consideration.			

#### F.3.11.8 Scoring preferences

Confirm that tenderers are eligible for the preferences claimed in accordance with the provisions of the tender data and reject all claims for preferences where tenderers are not eligible for such preferences. Calculate the total number of tender evaluation points for preferences claimed in accordance with the provisions of the tender data.

#### **F.3.11.9 Scoring functionality**

Score each of the criteria and subcriteria for quality in accordance with the provisions of the Tender Data.

Calculate the total number of tender evaluation points for quality using the following formula:

$$NQ = W2 \times SO / MS$$

where:

*SO is the score for quality allocated to the submission under consideration;*

*MS is the maximum possible score for quality in respect of a submission; and*

*W2 is the maximum possible number of tender evaluation points awarded for the quality as stated in the tender data*

#### **F.3.12 Insurance provided by the employer**

If requested by the proposed successful tenderer, submit for the tenderer's information the policies and / or certificates of insurance which the conditions of contract identified in the contract data, require the employer to provide.

#### **F.3.13 Acceptance of tender offer**

Accept the tender offer, if in the opinion of the employer, it does not present any risk and only if the tenderer:

- a) is not under restrictions, or has principals who are under restrictions, preventing participating in the employer's procurement,
- b) can, as necessary and in relation to the proposed contract, demonstrate that he or she possesses the professional and technical qualifications, professional and technical competence, financial resources, equipment and other physical facilities, managerial capability, reliability, experience and reputation, expertise, and the personnel, to perform the contract,
- c) has the legal capacity to enter into the contract,
- d) is not insolvent, in receivership, under Business Rescue as provided for in chapter 6 of the Companies Act, 2008, bankrupt or being wound up, has his affairs administered by **a court or a** judicial officer, has suspended his business activities, or is subject to legal proceedings in respect of any of the foregoing,
- e) complies with the legal requirements, if any, stated in the tender data, and
- f) is able, in the opinion of the employer, to perform the contract free of conflicts of interest.

#### **F.3.14 Prepare contract documents**

**F.3.14.1** If necessary, revise documents that shall form part of the contract and that were issued by the employer as part of the tender documents to take account of:

- a) addenda issued during the tender period,
- b) inclusion of some of the returnable documents, and
- c) other revisions agreed between the employer and the successful tenderer.

**F.3.14.2** Complete the schedule of deviations attached to the form of offer and acceptance, if any.

**F.3.15 Complete adjudicator's contract**

Unless alternative arrangements have been agreed or otherwise provided for in the contract, arrange for both parties to complete formalities for appointing the selected adjudicator at the same time as the main contract is signed.

**F.3.16 Notice to unsuccessful tenderers**

**F.3.16.1** Notify the successful tenderer of the employer's acceptance of his tender offer by completing and returning one copy of the form of offer and acceptance before the expiry of the validity period stated in the tender data, or agreed additional period.

**F.3.16.2** After the successful tenderer has been notified of the employer's acceptance of the tender, notify other tenderers that their tender offers have not been accepted.

**F.3.17 Provide copies of the contracts**

Provide to the successful tenderer the number of copies stated in the Tender Data of the signed copy of the contract as soon as possible after completion and signing of the form of offer and acceptance.

**F.3.18 Provide written reasons for actions taken**

Provide upon request written reasons to tenderers for any action that is taken in applying these conditions of tender but withhold information which is not in the public interest to be divulged, which is considered to prejudice the legitimate commercial interests of tenderers or might prejudice fair competition between tenderers.

**F3.19 Transparency in the procurement process**

**F3.19.1** The CIDB prescripts require that tenders must be advertised and be registered on the CIDB iTender system.

**F3.19.2** The employer must adopt a transparency model that incorporates the disclosure and accountability as transparency requirements in the procurement process.

**F3.19.3** The transparency model must identify the criteria for selection of projects, project information template and the threshold value of the projects to be disclosed in the public domain at various intervals of delivery of infrastructure projects.

**F3.19.4** The client must publish the information on a quarterly basis which contains the following information:

- Procurement planning process
- Procurement method and evaluation process
- Contract type
- Contract status
- Number of firms tendering
- Cost estimate
- Contract title
- Contract firm(s)
- Contract price
- Contract scope of work
- Contract start date and duration
- Contract evaluation reports

- F3.19.5** The employer must establish a Consultative Forum which will conduct a random audit in the implementation of the transparency requirements in the procurement process.
- F3.19.6** Consultative Forum must be an independent structure from the bid committees.
- F3.19.7** The information must be published on the employer's website.
- F 3.19.8** Records of such disclosed information must be retained for audit purposes.

**UMZIMKHULU BULK SEWER**

**CONSTRUCTION OF UMZIMKHULU BULK SEWER OUTFALL**

**CONTRACT No. HGDM 759/HGDM/2022**

**PART T2.1: RETURNABLE DOCUMENTS AND SCHEDULES**

**INDEX**

PART T2.1: LIST OF RETURNABLE DOCUMENTS AND SCHEDULES.....	<b>RD2</b>
FORM A: Certificate of Attendance at Clarification Meeting .....	<b>RD3</b>
FORM B: Authority for Signatory.....	<b>RD4</b>
FORM C: Certificate of Registration with CIDB.....	<b>RD6</b>
FORM D: Schedule of Work Carried out by the Tenderer .....	<b>RD7</b>
FORM E: Preliminary Programme .....	<b>RD11</b>
FORM F: Amendments, Qualifications and Alternatives .....	<b>RD12</b>
FORM G: Tenderer's Tax Pin Certificate.....	<b>RD14</b>
FORM H: Tenderer's Financial Standing .....	<b>RD15</b>
FORM I: Form of Intent to Provide a Performance Guarantee.....	<b>RD17</b>
FORM J: Compulsory Enterprise Questionnaire .....	<b>RD18</b>
FORM K: Proforma Client Reference of Projects .....	<b>RD20</b>
FORM L: Proof of Purchase of Tender Documents.....	<b>RD21</b>
FORM M: Preferential Procurement .....	<b>RD22</b>
FORM N: MBD4 Form .....	<b>RD36</b>
FORM O: BBBEE Certificate, Company Reg Doc & Other Doc.....	<b>RD39</b>
FORM P: Joint Venture Disclosure Form.....	<b>RD40</b>
FORM Q: Schedule of Const Plant & Equipment.....	<b>RD46</b>
FORM R: Schedule of Proposed Sub-Contractors .....	<b>RD47</b>
FORM S: Record of Addenda to Tender Documents .....	<b>RD48</b>
FORM T: Key Personnel .....	<b>RD49</b>
FORM U: Rates for Special Materials .....	<b>RD51</b>
FORM V: Contractor's Health and Safety Declaration .....	<b>RD52</b>
FORM W: UIF Registration Certificate .....	<b>RD54</b>
FORM X: Certificate of Municipal Services .....	<b>RD55</b>
FORM Y: Quality Management System .....	<b>RD55</b>



---

## **PART T2.2: LIST OF RETURNABLE DOCUMENTS AND SCHEDULES**

### **1. List of Returnable Documents and Schedules Required for Tender Evaluation Purposes**

- Certificate of Tenderers' Attendance at the Clarification Meeting
- Authority for Signatory
- Schedule of Work Carried out by the Tenderer
- Certificate of Registration with CIDB
- Preliminary Programme
- Amendments, Qualifications and Alternatives
- Tax Clearance Certificate
- BBBEE Certificate
- Tenderer's Financial Standing
- Form of Intent to Provide a Performance Guarantee
- Compulsory Enterprise Questionnaire
- UIF Registration Certificate
- Proof of Purchase of Tender Documents
- MBD4 Form
- Joint Venture Disclosure Form
- Company Registration Certificate
- Identity Documents
- VAT Registration Certificate
- Copy of Cashed Cheque for Company
- Project Specific Health and Safety Plan
- Certificate of Municipal Services

### **2. Other Returnable Schedules and Documents that Will be Incorporated into the Contract**

- Schedule of Construction Plant & Equipment
- Schedule of Proposed Sub-Contractors
- Record of Addenda to Tender Documents
- Rates for Special Materials
- Contractor's Health and Safety Declaration
- Form of Offer and Acceptance (Part C1)
- Contract Data (Part C1)
- Form of Guarantee (Part C1)
- Adjudicator's Agreement (Part C1)
- Agreement in Terms of the OHSA No 85 of 1993 (Part C1)
- Bill of Quantities (Part C2)
- Scope of Work (Part C3)
- Site information (Part C4)
- Drawings (Part C5)

**FORM A: Certificate of Attendance at Clarification Meeting**

**CONTRACT N° HGDM 759/HGDM/2022**

**CONSTRUCTION OF UMZIMKHULU BULK SEWER OUTFALL**

(Please print)

It is hereby CERTIFIED that I, ..... (name)  
in my capacity as.....and a duly authorized  
representative of..... (the TENDERER)  
of (address).....  
in the company of.....(the ENGINEER)  
attended the official Site Inspection on .....(date)  
for and on behalf of the above-named Tenderer.

I hereby further DECLARE that I am satisfied with the description of the Works and the explanations given by the above-named Engineer.

SIGNATURE .....  
(On behalf of TENDERER)

DATE .....

**AS WITNESS :-**  
(On behalf of ENGINEER)

NAME .....

SIGNATURE .....

DATE .....

**FORM B: Authority for Signatory**

Indicate the status of the tenderer by ticking the appropriate box hereunder. The tenderer must complete the certificate set out below for the relevant category.

A Company	B Partnership	C Joint Venture	D Sole Proprietor	E Close Corporation

**A. Certificate for Company**

I, ....., chairperson of the board of ....., hereby confirm that by resolution of the board (copy attached) taken on ..... 20....., Mr/Ms .....

acting in the capacity of ....., was authorised to sign all documents in connection with this tender for CONTRACT N° HGDM 759/HGDM/2022 and any contract resulting from it on behalf of the company.

**As witnesses:**

1. .... Chairman: .....
2. .... Date: .....

Signature of Authorised Person: .....

**B. Certificate for Partnership**

We, the undersigned, being the key partners in the business trading as ....., hereby authorise Mr/Ms ....., acting in the capacity of ....., to sign all documents in connection with this tender for CONTRACT N° HGDM 759/HGDM/2022 and any contract resulting from it on our behalf.

Name	Address	Signature	Date

*Note: This certificate is to be completed and signed by all key partners upon whom rests the direction of the affairs of the Partnership as a whole.*

Signature of Authorised Person: .....

**HARRY GWALA DISTRICT MUNICIPALITY**

**CONSTRUCTION OF UMZIMKHULU BULK SEWER OUTFALL**

**HGDM 759/HGDM/2022**

**C. Certificate for Joint Venture**

We, the undersigned, are submitting this tender offer in Joint Venture and hereby

authorise Mr/Ms ....., authorised signatory of the company

....., acting in the capacity of lead partner, to sign all documents in connection with this tender for CONTRACT HGDM 759/HGDM/2022 and any contract resulting from it on our behalf.

This authorisation is evidenced by the attached power of attorney signed by legally authorised signatories of all the partners to the Joint Venture.

<b>Name of Firm</b>	<b>Address</b>	<b>Authorising Name and Capacity</b>	<b>Authorising Signature</b>
Lead Partner:			

Signature of Authorised Person: .....

**D. Certificate for Sole Proprietor**

I, ....., hereby confirm that I am

the sole owner of the business trading as .....

**As witnesses:**

1. .... Sole Owner: .....

2. .... Date: .....

Signature of Authorised Person: .....

**E. Certificate for Close Corporation**

We, talculations must be set out in a clear and logical sequence and must clearly reflect all design assumptions in the development of the pricing proposal.

lect all design assumptions in the development of the pricing proposal.

ect all design assumptions in the development of the pricing proposal.

Acceptance of an alternative tender offer will mean acceptance in principle of the offer. It will be an obligation of the c° HGDM 759/HGDM/2022 and any contract resulting from it on our behalf.

<b>Name</b>	<b>Address</b>	<b>Signature</b>	<b>Date</b>

*Note: This certificate is to be completed and signed by all key partners upon whom rests the direction of the affairs of the Partnership as a whole.*

Signature of Authorised Person: .....

**HARRY GWALA DISTRICT MUNICIPALITY**

**CONSTRUCTION OF UMZIMKHULU BULK SEWER OUTFALL**

**HGDM 759/HGDM/2022**

**FORM C: Certificate of Registration with CIDB**

The Tenderer is to attach a copy (ies) of Tenderer's Registration with CIDB or alternatively furnish the CIDB registration number and details in the table below. This information will be verified with the CIDB through the CIDB website. It is the Tenderer's responsibility to ensure that their details are displayed on the website. If a joint venture is tendering, details of all the JV members are to be furnished.

<b>Name of Tenderer/Contractor</b>	<b>CIDB Registration Number</b>	<b>Category and Class of Registration e.g. 1CE</b>

My/Our failure to submit the certificate(s) or furnish the required details with my/our tender document will lead to the conclusion that I/we are not registered with CIDB and therefore are not eligible to tender.

SIGNATURE: .....  
*(of person authorised to sign on behalf of the Tenderer)*

DATE: .....

**FORM D 1: Schedule of Work Carried out by the Tenderer**

The Tenderer shall list below the last four civil engineering contracts of a similar nature awarded to him. This information is material to the award of the Contract. Provide list of Tenderer's experience in supply and Installation of uPVC Sewer outfalls or Pipelines greater than 300mm NB and greater than 500m In length.

<b>EMPLOYER</b> (Name, Tel No and Fax No)	<b>CONSULTING ENGINEER</b> (Name, Tel No and Fax No)	<b>NATURE OF WORK</b>	<b>VALUE OF WORK</b>	<b>YEAR OF COMPLETION</b>

SIGNATURE: .....  
(of person authorised to sign on behalf of the Tenderer)

DATE: .....

**FORM D 2: Schedule of Work Carried out by the Tenderer**

The Tenderer shall list below the last four civil engineering contracts of a similar nature awarded to him. This information is material to the award of the Contract. Provide list of Tenderer's experience in Refurbishment of existing sewers or pipe diameters equal to or greater than 160mm.

<b>EMPLOYER</b> (Name, Tel No and Fax No)	<b>CONSULTING ENGINEER</b> (Name, Tel No and Fax No)	<b>NATURE OF WORK</b>	<b>VALUE OF WORK</b>	<b>YEAR OF COMPLETION</b>

SIGNATURE: .....  
(of person authorised to sign on behalf of the Tenderer)

DATE: .....

**FORM D 3: Schedule of Work Carried out by the Tenderer**

The Tenderer shall list below the last four civil engineering contracts of a similar nature awarded to him. This information is material to the award of the Contract. Provide list of Tenderer's Experience In Trenchless Construction technology (Pipe Jacking).

<b>EMPLOYER</b> (Name, Tel No and Fax No)	<b>CONSULTING ENGINEER</b> (Name, Tel No and Fax No)	<b>NATURE OF WORK</b>	<b>VALUE OF WORK</b>	<b>YEAR OF COMPLETION</b>

SIGNATURE: .....  
(of person authorised to sign on behalf of the Tenderer)

DATE: .....



**FORM D 4: Schedule of Work Carried out by the Tenderer**

The Tenderer shall list below the last four civil engineering contracts of a similar nature awarded to him. This information is material to the award of the Contract. Provide list of Tenderer's experience in the Construction of Reinforced Concrete Structures 6m or higher.

<b>EMPLOYER</b> (Name, Tel No and Fax No)	<b>CONSULTING ENGINEER</b> (Name, Tel No and Fax No)	<b>NATURE OF WORK</b>	<b>VALUE OF WORK</b>	<b>YEAR OF COMPLETION</b>

SIGNATURE: .....  
(of person authorised to sign on behalf of the Tenderer)

DATE: .....



**FORM F: Amendments, Qualifications and Alternatives**

(This is not an invitation for amendments, deviations or alternatives but should the Tenderer desire to make any departures from the provisions of this contract he shall set out his proposals clearly hereunder. The Employer will not consider any amendment, alternative offers or discounts unless forms (a), (b) and (c) have been completed to the satisfaction of the Employer).

I / We herewith propose the amendments, alternatives and discounts as set out in the tables below:

**(a) AMENDMENTS**

<b>PAGE, CLAUSE OR ITEM NO</b>	<b>PROPOSED AMENDMENT</b>

Notes:

- (1) Proposals for amendments to the General and Special Conditions of Contract are not acceptable, and will be ignored;
- (2) The Tenderer must give full details of all the financial implications of the amendments and qualifications in a covering letter attached to his tender.

**(b) ALTERNATIVES**

<b>PROPOSED ALTERNATIVE</b>	<b>DESCRIPTION OF ALTERNATIVE</b>

Notes

**HARRY GWALA DISTRICT MUNICIPALITY**

**CONSTRUCTION OF UMZIMKHULU BULK SEWER OUTFALL**

**HGDM 759/HGDM/2022**

- (1) Individual alternative items that do not justify an alternative tender, and an alternative offer for time for completion should be listed here.
- (2) In the case of a major alternative to any part of the work, a separate Bill of Quantities, programme, etc, and a detailed statement setting out the salient features of the proposed alternatives must accompany the tender.
- (3) Alternative tenders involving technical modifications to the design of the works and methods of construction shall be treated separately from the main tender offer.

**(c) DISCOUNTS**

ITEM ON WHICH DISCOUNT IS OFFERED	DESCRIPTION OF DISCOUNT OFFERED

Note

The Tenderer must give full details of the discounts offered in a covering letter attached to his tender, failing which, the offer for a discount may have to be disregarded.]

SIGNATURE: ..... DATE: .....  
(of person authorised to sign on behalf of the Tenderer)

**FORM G: Tenderer's Tax Pin Certificate**

The Tenderer is to attach his original Tax Pin Certificate on this page. In the case of a Joint Venture, original copies of Tax Pin Certificates for all members of the Joint Venture must be attach.

**Tenderers must note that failure to comply with this requirement will render their tender invalid.**

**FORM H: Tenderer's Financial Standing**

**PLANNING AND DESIGN OF UMZIMKHULU BULK SEWER**

**CONSTRUCTION OF UMZIMKHULU BULK SEWER OUTFALL**

**HGDM 759/HGDM/2022**

The Employer may make inquiries to obtain a bank rating from the Tenderer's bank.

To this end, the Tenderer must provide with his tender, a bank rating, certified by his banker, to the effect that he will be able to successfully complete the contract at the tendered amount within the specified time for completion.

However, should the tenderer be unable to provide a bank rating with his tender, he shall be state the reasons thereof and in addition provide the following details of his banker and bank account details that he intends to use for the contract:

Name of Account Holder: .....

Name of Bank: ..... Branch: .....

Account Number: ..... Account Type: .....

Telephone Number: ..... Fax N<sup>o</sup>: .....

Name of Contact Person (*at bank*): .....

Failure to provide either the required bank details or a certified bank rating with his tender will lead to the conclusion that the Tenderer does not have the necessary financial resources at his disposal to complete the contract successfully within the specified time for completion.

The Employer undertakes to treat the information thus received as confidential, strictly for the use of evaluation of the tender submitted by the Tenderer.

SIGNATURE: .....  
(*of person authorised to sign on behalf of the Tenderer*)

DATE: .....

**CERTIFIED BANK RATING**

***Tenderers to attach a Certified Bank Rating to this page. Failure to comply may lead to awarding of zero points for quality on this criteria.***

**FORM I: Form of Intent to Provide a Performance Guarantee**

***[The Tenderer must attach hereto a letter from the bank or institution. with whom he has made the necessary arrangements, to the effect that the said bank or institution will be prepared to provide the required performance guarantee when asked to do so].***

*Tenderers are to refer to Form C1.3: Form of Guarantee*



**FORM J: Compulsory Enterprise Questionnaire**

The following particulars must be furnished. In the case of a joint venture, **separate** enterprise questionnaires in respect of each partner must be completed and submitted.

**Section 1: Name of enterprise:** .....

**Section 2: VAT registration number, if any:** .....

**Section 3: CIDB registration number, if any:** .....

**Section 4: Particulars of sole proprietors and partners in partnerships**

Name*	Identity number*	Personal income tax number*

\* Complete only if sole proprietor or partnership and attach separate page if more than 3 partners

**Section 5: Particulars of companies and close corporations**

Company registration number .....

Close corporation number .....

Tax reference number .....

**Section 6: Record of service of the state**

Indicate by marking the relevant boxes with a cross, if any sole proprietor, partner in a partnership or director, manager, principal shareholder or stakeholder in a company or close corporation is currently or has been within the last 12 months in the service of any of the following:

- |  |   |
|--|---|
| <input type="checkbox"/> a member of any municipal council                                     | <input type="checkbox"/> an employee of any provincial department, national or provincial public entity or constitutional institution within the meaning of the Public Finance Management Act, 1999 (Act 1 of 1999) |
| <input type="checkbox"/> a member of any provincial legislature                                | <input type="checkbox"/> a member of an accounting authority of any national or provincial public entity  |
| <input type="checkbox"/> a member of the National Assembly or the National Council of Province | <input type="checkbox"/> an employee of Parliament or a provincial legislature  |
| <input type="checkbox"/> a member of the board of directors of any municipal entity            |   |
| <input type="checkbox"/> an official of any municipality or municipal entity                   |   |

**If any of the above boxes are marked, disclose the following:**

Name of sole proprietor, partner, director, manager, principal shareholder or stakeholder	Name of institution, public office, board or organ of state and position held	Status of service (tick appropriate column)	
		current	Within last 12 months

\*insert separate page if necessary

**HARRY GWALA DISTRICT MUNICIPALITY**

**CONSTRUCTION OF UMZIMKHULU BULK SEWER OUTFALL**

**HGDM 759/HGDM/2022**

**Section 7: Record of spouses, children and parents in the service of the state**

Indicate by marking the relevant boxes with a cross, if any spouse, child or parent of a sole proprietor, partner in a partnership or director, manager, principal shareholder or stakeholder in a company or close corporation is currently or has been within the last 12 months been in the service of any of the following:

- |  |   |
|--|---|
| <input type="checkbox"/> a member of any municipal council                                     | <input type="checkbox"/> an employee of any provincial department, national or provincial public entity or constitutional institution within the meaning of the Public Finance Management Act, 1999 (Act 1 of 1999) |
| <input type="checkbox"/> a member of any provincial legislature                                | <input type="checkbox"/> a member of an accounting authority of any national or provincial public entity  |
| <input type="checkbox"/> a member of the National Assembly or the National Council of Province | <input type="checkbox"/> an employee of Parliament or a provincial legislature  |
| <input type="checkbox"/> a member of the board of directors of any municipal entity            |   |
| <input type="checkbox"/> an official of any municipality or municipal entity                   |   |

Name of spouse, child or parent	Name of institution, public office, board or organ of state and position held	Status of service (tick appropriate column)	
		current	Within last 12 months

\*insert separate page if necessary

The undersigned, who warrants that he/she is duly authorised to do so on behalf of the enterprise:

- i) authorizes the Employer to obtain a tax pin certificate from the South African Revenue Services that my / our tax matters are in order;
- ii) confirms that the neither the name of the enterprise or the name of any partner, manager, director or other person, who wholly or partly exercises, or may exercise, control over the enterprise appears on the Register of Tender Defaulters established in terms of the Prevention and Combating of Corrupt Activities Act of 2004;
- iii) confirms that no partner, member, director or other person, who wholly or partly exercises, or may exercise, control over the enterprise appears, has within the last five years been convicted of fraud or corruption;
- iv) confirms that I / we are not associated, linked or involved with any other tendering entities submitting tender offers and have no other relationship with any of the tenderers or those responsible for compiling the scope of work that could cause or be interpreted as a conflict of interest;
- iv) confirms that the contents of this questionnaire are within my personal knowledge and are to the best of my belief both true and correct;

Signed \_\_\_\_\_ Date \_\_\_\_\_

Name \_\_\_\_\_ Position \_\_\_\_\_

Name of Enterprise \_\_\_\_\_

**FORM K: Proforma Client Reference of Projects**

The Tenderer must request previous Client/Referee to be complete this form for two projects for their respective pipeline reticulation projects (as claimed in the Tenderers Experience Schedule). The completed and signed forms to be submitted with the Tender.

**PROFORMA REPORT ON THE TENDERER'S COMPETENCE AND PERFORMANCE ON PIPELINE RETICULATION PROJECT FOR TENDER EVALUATION PURPOSES**

The following form will be requested to be completed by the Tenderers previous Clients.

**Project Details:**

Description of work: .....

Employer: .....

Value of work: .....

Contract Duration and Commencement Date: .....

Diameter of pipelines: .....

Length of pipelines: .....

	<b>Qualitative Statements as assessed by Referees</b>	<b>Points</b>	<b>Score</b>
1	"Contractor's Management was adequate for the contract"		
2	"Contractor provided suitably qualified Site personnel"	Unacceptable	0
3	"Contractor's provided adequate resources for the contract"	Poor	1
		Below Average	2
4	"Contractor's communication and compliance to instructions was good"	Average	3
		Above Average	4
5	"Quality of work produced was to drawings and specification"	Good	5
6	"Contract was completed on time"		
	<b>Total Points Obtained</b>		

Any other remarks considered necessary to assist in evaluation of the Service Provider?

.....  
 .....

Client's/ contact person & Capacity: .....

Telephone: .....

Client Signature: .....

Date: .....

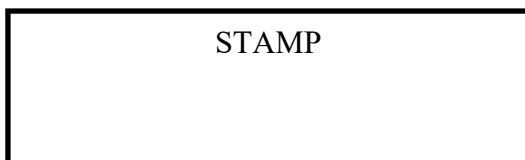

**FORM L: Proof of Purchase of Tender Documents**

The Tenderer shall insert here proof of purchase of the tender documents in the form of an official receipt or other acceptable form of proof

## FORM M: Preferential Procurement

Harry Gwala District Municipality has adopted the Preference Point System as stipulated in the Preferential Procurement Policy Framework Act, 2000 (Act No. 5 of 2000) and as set out in the 2017 regulations.

### M.1. PRINCIPLES APPLIED BY THE MUNICIPALITY

- 1.1 The Harry Gwala District Municipality has a responsibility to ensure that resources are managed in the most efficient and effective manner possible. This aim forms part of a national objective to manage the use of the resources of the nation in a thrifty, careful and economic manner and in such a way as to maximise sustained economic growth. The Municipality also has a responsibility to ensure that its activities further other overall national objectives of equity and redress, and to balance the furthering of these objectives in a manner that is fair and transparent. The Municipality is committed, therefore, to a process of cost effective, competitive procurement for goods and services that incorporates a targeted preferential methodology aimed at furthering the growth and development of persons, or categories of persons, historically disadvantaged by unfair discrimination on the basis of race, gender or disability.
- 1.2 No contract for the supply of any goods to or for any work, undertaking or service for or on behalf of the Harry Gwala District Municipality involving an estimated expenditure in excess of an amount prescribed in the Municipality's Preferential Procurement/Supply Chain Management Policy shall be entered into by the Municipality, unless public tenders have been called for in the manner prescribed.
- 1.3 Furthermore, the Harry Gwala District Municipality shall, in accordance with the framework prescribed by national legislation, give preference in awarding contracts to persons or categories of persons historically disadvantaged by unfair discrimination on the basis of race, gender or disability, and shall make the granting of such preferences public in the manner determined in the policy.

### M.2 The 80/20 Preference Point System

The procedure for the evaluation of responsive tenders is **Method 2** with the 80/20 Preference Point System. Tenderers will be scored for quality first and only those tenders that meet the specified minimum total score for quality will be considered further. These tenders will then be evaluated on the basis of the 80/20 Preference Points System.

#### Method 2: Financial Offer, Quality and Preferences

##### (a) Quality

The score for quality is to be calculated using the following formula:

$$W_q = W_2 \times S_o / M_s$$

where:

$W_2$  = is the percentage score given to quality and equals **100**

$S_o$  = is the score for quality allocated to the submission under consideration

$M_s$  = is the maximum possible score for quality in respect to the submission

The quality will comprise scores for the following based on criteria indicated in the respective tender returnables:

**HARRY GWALA DISTRICT MUNICIPALITY**

**CONSTRUCTION OF UMZIMKHULU BULK SEWER OUTFALL**

**HGDM 759/HGDM/2022**

<b>Criteria</b>			<b>Total Weighting %</b>
Tenderer's experience in supply and Installation of uPVC Sewer outfalls or Pipelines greater than 300mm NB and greater than 500m In length.	No of Projects completed	Points	18
	1 Project	4	
	2 Projects	8	
	3 Projects	13	
	4 Projects	18	
Tenderer's experience in Refurbishment of existing sewers or pipe diameters equal to or greater than 160mm	No of Projects completed	Points	15
	1 Project	3	
	2 Projects	8	
	3 Projects	12	
	4 Projects	15	
Tenderer's experience in Trenchless Construction technology (Pipe Jacking).	No of Projects completed	Points	20
	1 Project	5	
	2 Projects	10	
	3 Projects	15	
	4 Projects	20	
Tenderer's experience in the Construction of Reinforced Concrete Structures 6m or higher.	No of Projects completed	Points	21
	1 Project	5	
	2 Projects	10	
	3 Projects	15	
	4 Projects	21	
Financial Resources	Bank Rating	Points	5
	Rating A	5	
	Rating B		
	Rating C		
	Rating D		
Rating E	0		
Rating F			
Rating G			
Rating H			
Experience of Key Personnel	Key Personnel	Experience	16
	Contracts Manager: Relevant Professional Registration with ECSA or SACPCMP with more than 5 years' appropriate experience	2	
	Construction Manager / Site Agent: Relevant Professional Registration with ECSA or SACPCMP with more than 8 years' of appropriate experience	6	
	Structural Foreman: With more than 10 years' appropriate experience	6	
	Pipe Laying Foreman: With more than 8 years' appropriate experience	2	

**HARRY GWALA DISTRICT MUNICIPALITY**

**CONSTRUCTION OF UMZIMKHULU BULK SEWER OUTFALL**

**HGDM 759/HGDM/2022**

Quality Assurance Plan and Control Procedures	Score Status	Points	5
	Have ISO 9001 Accreditation	5	
	Have Own Internal QA Plan	3	
	None	0	
<b>Total Possible Points</b>			<b>100</b>

**Tenderers that score less than 60% of the total score allowed for quality will not be considered further.**

(b) Financial Offer

The financial offer will be scored using the following formula

Price Points: 80 Points Maximum

The following formula will be used to calculate the points for price in respect of tenders with a Rand value up to R50 000,000:-

$$Ps = 80 \left\{ 1 - \frac{(Pt - Pmin)}{Pmin} \right\}$$

Where:-

- Ps** = Points scored for price of tender under consideration  
**Pt** = Rand value of offer tender consideration  
**Pmin** = Rand value of lowest acceptable tender

(c) Preferences

Up to **20** points (for financial values up to R50 000 000) or **10** points (for financial values over R50 000 000) will be awarded to tenderers who are found to be eligible for the preference claimed.

Points will be awarded to Tenderers for attaining the BBBEE status level of contribution as per the Preferential Procurement Policy Framework Act, 2000: Preferential Procurement Regulations, 2017 as detailed below.

<b>BBBEE Contributor</b>	<b>Status Level</b>	<b>Number of Points (90/10 Principle)</b>	<b>Number of Points (80/20 Principle)</b>
	1	10	20
	2	9	18
	3	8	14
	4	6	12
	5	4	8
	6	3	6
	7	2	4
	8	1	2
Non-Compliant Contributor		0	0

(d) Example of Adjudication Schedule

A typical example of the tender evaluation process and schedule is shown in the table below.

HARRY GWALA DISTRICT MUNICIPALITY

CONSTRUCTION OF UMZIMKHULU BULK SEWER OUTFALL

HGDM 759/HGDM/2022

STAGE 1	STAGE 2	STAGE 3	STAGE 4	STAGE 5		STAGE 6	STAGE 7	STAGE 8	STAGE 9
Name of Tenderer	Price Tendered	Is Tenderer Responsive	Has Tenderer Scored adequate Points for Functionality	Risk Assessment			Points Allocation		
				Tendered Time for Completion Realistic	Has Tenderer got the plant and equipment	Are Rates & Price Realistic	Points for Price	Points for BBEE Status Level of Contribution	Total Points
A	50 000	Yes	Yes	6 Months	YES	NO	0	0	0
B	200 000	Yes	Yes	5 Months	YES	YES	80	2	82
<b>C</b>	<b>210 000</b>	<b>Yes</b>	<b>Yes</b>	<b>6 Months</b>	YES	<b>YES</b>	<b>76.0</b>	<b>8</b>	<b>84.0</b>
D	235 000	Yes	Yes	7 Months	YES	YES	66.0	5	83.8
E	235 000	Yes	Yes	5 Months	YES	YES	66.0	5	83.8
F	600 000	Yes	Yes	6 Months	YES	NO	0	0	0
G	240 000	No	N/A	N/A	YES	N/A	0	0	0

Calculation of Price Points - Tendered	Calculation of Development Points - Tendered
$N_p = 80 \left\{ 1 - \left( \frac{P - P_{min}}{P_{min}} \right) \right\}$ $N_p = 80 \left\{ 1 - \left( \frac{210\,000 - 200\,000}{200\,000} \right) \right\}$ $= 80 \times (1 - 0.05)$ $= 80 \times 0.95$ <p><b>Np = 76.0</b></p>	<p><b>BBBEE status level of contribution</b></p> <p>= 8 points</p>
<b>TOTAL ADJUDICATION POINTS = 76.0 + 8 = 84.0 POINTS</b>	

**M.3 Bidder Submission Requirements**



All bidders must provide the following information and certificates with their bids and may not consider any quotation or bid submitted by a service provider who fails to submit the following information:

- All potential or actual conflicts of interests
- The name of the entity or person
- Whether the owner is or has been in the service of the state in the previous 12 months
- If the provider is not a natural person, whether any of its directors, managers, principle shareholders or stakeholders is in the service of the state or has been in the previous 12 months
- Whether a spouse, child or parent of the provider or of a director, manager shareholder or stakeholder is in the service of the state or has been in the previous 12 months
- Tax reference numbers, including Tax, PAYE, UIF and SDL and VAT, if applicable
- Identification or company registration numbers
- A valid Tax Pin certificate issued by SARS
- BBEEE Certificate for tendering entity. For joint ventures, the BBEEE certificates for the individual JV members should be submitted.
- Registration with relevant bodies or controlling authorities if such registrations are mandatory
- Employment Equity Registration Numbers from the Department of Labour, if applicable
- Proof of registration and a letter of good standing from the Compensation Commissioner in compliance with COID Act.
- Proof that municipal rates, taxes and service charges accounts are in order

#### **M.4 Adjudication Criteria**

Adjudications will be conducted in accordance with the prescribed formulae as indicated in the Preferential Procurement Policy Framework Act and the Broad-Based Black Economic Empowerment Act and scorecards. Adjudication criteria will be clearly stated in the bid documents.

The award must be made to the bidder scoring the highest number of points unless objective criteria indicate that the award should be made to another bidder. The reasons for deviating from the prescribed norms and standards must be documented by the bid adjudication committee and reported immediately to the Accounting Officer. The Accounting Officer may at any stage, refer any recommendations made by either the bid evaluation or bid adjudication committees back to those committees for reconsideration.

#### **M.5 Rejection / Disqualification Criteria**

The Municipality may disqualify any offer or bid submitted for the following reasons:

- (i) The bidder failed to comply with all submission requirements as stated in the tender document.
- (ii) The entity or one of its directors is listed on National Treasury's data base as a person prohibited from doing business with the public sector
- (iii) There are levies for water & sanitation service charges from any Municipality by the entity or any of its directors that are in arrears for longer than 3 months unless credit arrangements have been made in terms of council policies.
- (iv) The entity has failed to perform satisfactorily on previous contracts with any Municipality or other organ of state, after that entity was given written notice that performance was unsatisfactory
- (v) Any of the directors committed a corrupt or fraudulent act in competing for a particular contract or in the execution of a contract
- (vi) An Official or other role player committed any corrupt or fraudulent act during the bidding process or the execution of a contract that benefited that person

- (vii) The entity or any of its directors abused the supply chain management system or committed any improper conduct in relation to such system
- (viii) Any director has been convicted for fraud or corruption during the past 5 years
- (ix) Has wilfully neglected, reneged on or failed to comply with any government, municipal or other public sector contract during the last 5 years
- (x) Misrepresentation of facts or information in the tender document submitted.
- (xi) Submission of two tender documents (from the same company) unless the other tender document is an alternative offer.
- (xii) Any persons whose tax matters have not been declared as being in order by the South African Revenue Services for awards in excess of R15, 000 Inc VAT.

**M.6 Payments**

Payments for Small and Micro projects shall be made within 30 days after submission of an acceptable invoice which has been approved by the Municipality's Representative or as specified in the Municipality's Special Conditions of Contract.

**M.7 Assignment**

The Service Provider may not cede or assign this contract or any moneys due or that may become due to it, without the prior written consent of the Municipality.

**M.8 Joint Ventures**

The Municipality will only accept Joint Venture agreements that are formed as a new legal entity and where an acceptable and legal agreement is submitted to the municipality. Any payments due to the Joint Venture will be made to the JV bank account.

**M.9 Penalties (Construction Contracts and where Necessary)**

Penalties on late completion of work shall be as specified in the Contract Data.

**PREFERENTIAL PROCUREMENT POLICY FRAMEWORK ACT, 2000:  
PREFERENTIAL PROCUREMENT REGULATIONS, 2017**

The Minister of Finance has, in terms of section 5 of the Preferential Procurement Policy Framework Act, 2000 (Act No. 5 of 2000), made the regulations set out in the Schedule.

**SCHEDULE  
Preferential Procurement Regulations, 2017**

**Contents**

1. Definitions
2. Application
3. Identification of preference point system, designated sector, pre-qualification criteria, objective criteria and subcontracting
4. Prequalification criteria for preferential procurement
5. Tenders to be evaluated on functionality
6. 80/20 preference point system for acquisition of goods or services for Rand value equal to or above R30 000 and up to R50 million
7. 90/10 preference point system for acquisition of goods or services with Rand value above R50 million
8. Local production and content
9. Subcontracting as condition of tender
10. Criteria for breaking deadlock in scoring
11. Award of contracts to tenderers not scoring highest points
12. Subcontracting after award of tender
13. Cancellation of tender
14. Remedies
15. Circulars and guidelines
16. Repeal of Regulations and saving
17. Short title and commencement

**Definitions**

1. In these Regulations, unless the context indicates otherwise, any word or expression to which a meaning has been assigned in the Act must bear the meaning so assigned-

“**B-BBEE**” means broad-based black economic empowerment as defined in section 1 of the Broad-Based Black Economic Empowerment Act;

“**B-BBEE status level of contributor**” means the B-BBEE status of an entity in terms of a code of good practice on black economic empowerment issued in terms of section 9(1) of the Broad-Based Black Economic Empowerment Act;

“**black designated groups**” has the meaning assigned to it in the codes of good practice issued in terms of section 9(1) of the Broad-Based Black Economic Empowerment Act;

“**black people**” has the meaning assigned to it in section 1 of the Broad-Based Black Economic Empowerment Act;

“**Broad-Based Black Economic Empowerment Act**” means the Broad-Based Black Economic Empowerment Act, 2003 (Act No. 53 of 2003);

“**co-operative**” means a co-operative registered in terms of section 7 of the Cooperatives Act, 2005 (Act No. 14 of 2005);

“**designated group**” means-

- (a) black designated groups;
- (b) black people;

(c) women;

(d) people with disabilities; or

(e) small enterprises, as defined in section 1 of the National Small Enterprise Act, 1996 (Act No. 102 of 1996);

**“designated sector”** means a sector, sub-sector or industry or product designated in terms of regulation 8(1)(a);

**“EME”** means an exempted micro enterprise in terms of a code of good practice on black economic empowerment issued in terms of section 9(1) of the Broad-Based Black Economic Empowerment Act;

**“functionality”** means the ability of a tenderer to provide goods or services in accordance with specifications as set out in the tender documents;

**“military veteran”** has the meaning assigned to it in section 1 of the Military Veterans Act, 2011 (Act No. 18 of 2011);

**“National Treasury”** has the meaning assigned to it in section 1 of the Public Finance Management Act, 1999 (Act No. 1 of 1999);

**“people with disabilities”** has the meaning assigned to it in section 1 of the Employment Equity Act, 1998 (Act No. 55 of 1998);

**“price”** includes all applicable taxes less all unconditional discounts;

**“proof of B-BBEE status level of contributor”** means-

(a) the B-BBEE status level certificate issued by an authorised body or person;

(b) a sworn affidavit as prescribed by the B-BBEE Codes of Good Practice; or

(c) any other requirement prescribed in terms of the Broad-Based Black Economic Empowerment Act;

**“QSE”** means a qualifying small business enterprise in terms of a code of good practice on black economic empowerment issued in terms of section 9(1) of the Broad-Based Black Economic Empowerment Act;

**“Rand value”** means the total estimated value of a contract in Rand, calculated at the time of the tender invitation;

**“rural area”** means-

(a) a sparsely populated area in which people farm or depend on natural resources, including villages and small towns that are dispersed through the area; or

(b) an area including a large settlement which depends on migratory labour and remittances and government social grants for survival, and may have a traditional land tenure system;

**“stipulated minimum threshold”** means the minimum threshold stipulated in terms of regulation 8(1)(b);

**“the Act”** means the Preferential Procurement Policy Framework Act, 2000 (Act No. 5 of 2000);

**“township”** means an urban living area that any time from the late 19th century until 27 April 1994, was reserved for black people, including areas developed for historically disadvantaged individuals post 27 April 1994;

**“treasury”** has the meaning assigned to it in section 1 of the Public Finance Management Act, 1999 (Act No. 1 of 1999); and

**“youth”** has the meaning assigned to it in section 1 of the National Youth Development Agency Act, 2008 (Act No. 54 of 2008).

### **Application**

**2.** These Regulations apply to organs of state as envisaged in the definition of organ of state in section 1 of the Act.1

**Identification of preference point system, designated sector, pre-qualification criteria, objective criteria and subcontracting**

**3. An organ of state must-**

(a) determine and stipulate in the tender documents-

(i) the preference point system applicable to the tender as envisaged in regulation 6 or 7; or

(ii) if it is unclear which preference point system will be applicable, that either the 80/20 or 90/10 preference point system will apply and that the lowest acceptable tender will be used to determine the applicable preference point system;

(b) determine whether pre-qualification criteria are applicable to the tender as envisaged in regulation 4;

(c) determine whether the goods or services for which a tender is to be invited, are in a designated sector for local production and content as envisaged in regulation 8;

(d) determine whether compulsory subcontracting is applicable to the tender as envisaged in regulation 9; and

(e) determine whether objective criteria are applicable to the tender as envisaged in regulation 11.

**Pre-qualification criteria for preferential procurement**

4.(1) If an organ of state decides to apply pre-qualifying criteria to advance certain designated groups, that organ of state must advertise the tender with a specific tendering condition that only one or more of the following tenderers may respond-

(a) a tenderer having a stipulated minimum B-BBEE status level of contributor;

(b) an EME or QSE;

(c) a tenderer subcontracting a minimum of 30% to-

(i) an EME or QSE which is at least 51% owned by black people;

(ii) an EME or QSE which is at least 51% owned by black people who are youth;

(iii) an EME or QSE which is at least 51% owned by black people who are women;

(iv) an EME or QSE which is at least 51% owned by black people with disabilities;

(v) an EME or QSE which is 51% owned by black people living in rural or underdeveloped areas or townships;

(vi) a cooperative which is at least 51% owned by black people;

(vii) an EME or QSE which is at least 51% owned by black people who are military veterans;

(viii) an EME or QSE.

(2) A tender that fails to meet any pre-qualifying criteria stipulated in the tender documents is an unacceptable tender.

**Tenders to be evaluated on functionality**

5.(1) An organ of state must state in the tender documents if the tender will be evaluated on functionality.

(2) The evaluation criteria for measuring functionality must be objective.

(3) The tender documents must specify-

(a) the evaluation criteria for measuring functionality;

(b) the points for each criteria and, if any, each sub-criterion; and

(c) the minimum qualifying score for functionality

---

<sup>1</sup>The definition of "organ of state" in section 1 of the Act in paragraph (a) to (e) includes-

- a national or provincial department as defined in the Public Finance Management Act, 1999;
- a municipality as contemplated in the Constitution;
- a constitutional institution as defined in the Public Finance Management Act;
- Parliament;
- a provincial legislature.

Paragraph (f) of the definition of organ of state in section 1 of the Act includes any other institution or category of institutions included in the definition of "organ of state" in section 239 of the Constitution and recognised by the Minister by notice in the *Government Gazette* as an institution or category of institutions to which the Act applies. Government Notice R. 501 of 8 June 2011 recognises, with effect from 7 December 2011, all public entities listed in Schedules 2 and 3 to the Public Finance Management Act, 1999, as institutions to which the Act applies. Note should be taken of notices issued from time to time in terms of paragraph (f) of this definition. The application of these Regulations is also subject to applicable exemptions approved in terms of section 3 of the Act.

- (4) The minimum qualifying score for functionality for a tender to be considered further-
- (a) must be determined separately for each tender; and
  - (b) may not be so-
    - (i) low that it may jeopardise the quality of the required goods or services; or
    - (ii) high that it is unreasonably restrictive.
- (5) Points scored for functionality must be rounded off to the nearest two decimal places.
- (6) A tender that fails to obtain the minimum qualifying score for functionality as indicated in the tender documents is not an acceptable tender.
- (7) Each tender that obtained the minimum qualifying score for functionality must be evaluated further in terms of price and the preference point system and any objective criteria envisaged in regulation 11.

**80/20 preference point system for acquisition of goods or services for Rand value equal to or above R30 000 and up to R50 million**

6.(1) The following formula must be used to calculate the points out of 80 for price in respect of a tender with a Rand value equal to or above R30 000 and up to a Rand value of R50 million, inclusive of all applicable taxes:

$$Ps = 80 \left\{ 1 - \frac{(Pt - Pmin)}{Pmin} \right\}$$

Where:-

- Ps = Points scored for price of tender under consideration
- Pt = Rand value of offer tender consideration
- Pmin = Rand value of lowest acceptable tender

(2) The following table must be used to calculate the score out of 20 for BBEE:

BBEE Status Level Contributor	Number of Points
1	20
2	18
3	14
4	12
5	8
6	6
7	4
8	2
Non-Compliant Contributor	0

- (3) A tenderer must submit proof of its B-BBEE status level of contributor.
- (4) A tenderer failing to submit proof of B-BBEE status level of contributor or is a non-compliant contributor to B-BBEE may not be disqualified, but-
- (a) may only score points out of 80 for price; and
  - (b) scores 0 points out of 20 for B-BBEE.
- (5) A tenderer may not be awarded points for B-BBEE status level of contributor if the tender documents indicate that the tenderer intends subcontracting more than 25% of the value of the contract to any other person not qualifying for at least the points that the tenderer qualifies for, unless the intended subcontractor is an EME that has the capability to execute the subcontract.
- (6) The points scored by a tenderer for B-BBEE in terms of subregulation (2) must be added to the points scored for price under subregulation (1).
- (7) The points scored must be rounded off to the nearest two decimal places.
- (8) Subject to subregulation (9) and regulation 11, the contract must be awarded to the tenderer scoring the highest points.
- (9) (a) If the price offered by a tenderer scoring the highest points is not marketrelated, the organ of state may not award the contract to that tenderer.
- (b) The organs of state may-
- (i) negotiate a market-related price with the tenderer scoring the highest points or cancel the tender;

- (ii) if the tenderer does not agree to a market-related price, negotiate a market-related price with the tenderer scoring the second highest points or cancel the tender;
- (iii) if the tenderer scoring the second highest points does not agree to a market-related price, negotiate a market-related price with the tenderer scoring the third highest points or cancel the tender.
- (c) If a market-related price is not agreed as envisaged in paragraph (b)(iii), the organ of state must cancel the tender.

**90/10 preference point system for acquisition of goods or services with Rand value above R50 million**

7.(1) The following formula must be used to calculate the points out of 90 for price in respect of a tender with a Rand value above R50 million, inclusive of all applicable taxes:

Where

- Ps = Points scored for price of tender under consideration;
- Pt = Price of tender under consideration; and
- Pmin = Price of lowest acceptable tender.

(2) The following table must be used to calculate the points out of 10 for BBBEE:

BBBEE Status Level Contributor	Number of Points
1	10
2	9
3	6
4	5
5	4
6	3
7	2
8	1
Non-Compliant Contributor	0

- (3) A tenderer must submit proof of its B-BBEE status level of contributor.
- (4) A tenderer failing to submit proof of B-BBEE status level of contribution or is a non-compliant contributor to B-BBEE may not be disqualified, but-
  - (a) may only score points out of 90 for price; and
  - (b) scores 0 points out of 10 for B-BBEE.
- (5) A tenderer may not be awarded points for B-BBEE status level of contributor if the tender documents indicate that the tenderer intends subcontracting more than 25% of the value of the contract to any other person not qualifying for at least the points that the tenderer qualifies for, unless the intended subcontractor is an EME that has the capability to execute the subcontract.
- (6) The points scored by a tenderer for B-BBEE contribution in terms of subregulation (2) must be added to the points scored for price under subregulation (1).
- (7) The points scored must be rounded off to the nearest two decimal places.
- (8) Subject to subregulation (9) and regulation 11, the contract must be awarded to the tenderer scoring the highest points.
- (9)
  - (a) If the price offered by a tenderer scoring the highest points is not market related, the organ of state may not award the contract to that tenderer.
  - (b) The organs of state may-
    - (i) negotiate a market-related price with the tenderer scoring the highest points or cancel the tender;
    - (ii) if the tenderer does not agree to a market-related price, negotiate a market-related price with the tenderer scoring the second highest points or cancel the tender;
    - (iii) if the tenderer scoring the second highest points does not agree to a market-related price, negotiate a market-related price with the tenderer scoring the third highest points or cancel the tender.
  - (c) If a market-related price is not agreed as envisaged in paragraph (b)(iii), the organ of state must cancel the tender.

### Local production and content

- 8.(1) The Department of Trade and Industry may, in consultation with the National Treasury-
- (a) designate a sector, sub-sector or industry or product in accordance with national development and industrial policies for local production and content, where only locally produced services or goods or locally manufactured goods meet the stipulated minimum threshold for local production and content, taking into account economic and other relevant factors; and
  - (b) stipulate a minimum threshold for local production and content.
- (2) An organ of state must, in the case of a designated sector, advertise the invitation to tender with a specific condition that only locally produced goods or locally manufactured goods, meeting the stipulated minimum threshold for local production and content, will be considered.
- (3) The National Treasury must inform organs of state of any designation made in terms of regulation 8(1) through a circular.
- (4) (a) If there is no designated sector, an organ of state may include, as a specific condition of the tender, that only locally produced services or goods or locally manufactured goods with a stipulated minimum threshold for local production and content, will be considered.  
(b) The threshold referred to in paragraph (a) must be in accordance with the standards determined by the Department of Trade and Industry in consultation with the National Treasury.
- (5) A tender that fails to meet the minimum stipulated threshold for local production and content is an unacceptable tender.

### Subcontracting as condition of tender

- 9.(1) If feasible to subcontract for a contract, an organ of state must apply subcontracting to advance designated groups.
- (2) If an organ of state applies subcontracting as contemplated in sub regulation (1), the organ of state must advertise the tender with a specific tendering condition that the successful tenderer must subcontract a minimum of threshold of the value of the contract as follows:
- Subcontracting to start from R5 million to be 5%
  - Appoint 2 sub-contractors between R10 million to R20 million at R1.5 million each
  - Appoint 3 sub-contractors for R30 million at R3 million each
  - Sub-contractors to be mentored and capacitated by main contractor

The subcontractors are to be from the following designated groups: an EME or OSE;

28 No . 40553 GOVERNMENT GAZETTE, 20 JANUARY 2017

- (b) an EME or QSE which is at least 51% owned by black people;
  - (c) an EME or QSE which is at least 51% owned by black people who are youth ;
  - (d) an EME or QSE which is at least 51% owned by black people who are women;
  - (e) an EME or QSE which is at least 51% owned by black people with disabilities ;
  - (f) an EME or QSE which is 51% owned by black people living in rural or underdeveloped areas or townships;
  - (g) a cooperative which is at least 51% owned by black people;
  - (h) an EME or QSE which is at least 51% owned by black people who are military veterans; or
  - (i) more than one of the categories referred to in paragraphs (a) to (h).
- (3) The organ of state must make available the list of all suppliers registered on a database approved by the National Treasury to provide the required goods or services in respect of the applicable designated groups mentioned in subregulation (2) from which the tenderer must select a supplier.

### Criteria for breaking deadlock in scoring

- 10.(1) If two or more tenderers score an equal total number of points, the contract must be awarded to the tenderer that scored the highest points for B-BBEE.
- (2) If functionality is part of the evaluation process and two or more tenderers score equal total points and equal preference points for B-BBEE, the contract must be awarded to the tenderer that scored the highest points for functionality.



(3) If two or more tenderers score equal total points in all respects, the award must be decided by the drawing of lots.

#### **Award of contracts to tenderers not scoring highest points**

11.(1) A contract may be awarded to a tenderer that did not score the highest points only in accordance with section 2(1)(f) of the Act.

(2) If an organ of state intends to apply objective criteria in terms of section 2(1)(f) of the Act, the organ of state must stipulate the objective criteria in the tender documents.

#### **Subcontracting after award of tender**

12.(1) A person awarded a contract may only enter into a subcontracting arrangement with the approval of the organ of state.

(2) A person awarded a contract in relation to a designated sector, may not subcontract in such a manner that the local production and content of the overall value of the contract is reduced to below the stipulated minimum threshold.

(3) A person awarded a contract may not subcontract more than 25% of the value of the contract to any other enterprise that does not have an equal or higher B-BBEE status level of contributor than the person concerned, unless the contract is subcontracted to an EME that has the capability and ability to execute the subcontract.

#### **Cancellation of tender**

13. (1) An organ of state may, before the award of a tender, cancel a tender invitation if-

- (a) due to changed circumstances, there is no longer a need for the goods or services specified in the invitation;
- (b) funds are no longer available to cover the total envisaged expenditure;
- (c) no acceptable tender is received; or
- (d) there is a material irregularity in the tender process.

(2) The decision to cancel a tender invitation in terms of sub regulation (1) must be published in the same manner in which the original tender invitation was advertised.

(3) An organ of state may only with the prior approval of the relevant treasury cancel a tender invitation for the second time.

#### **Remedies**

14.(1) Upon detecting that a tenderer submitted false information regarding its BBBEE status level of contributor, local production and content, or any other matter required in terms of these Regulations which will affect or has affected the evaluation of a tender, or where a tenderer has failed to declare any subcontracting arrangements, the organ of state must-

- (a) inform the tenderer accordingly;
- (b) give the tenderer an opportunity to make representations within 14 days as to why-
  - (i) the tender submitted should not be disqualified or, if the tender has already been awarded to the tenderer, the contract should not be terminated in whole or in part;
  - (ii) if the successful tenderer subcontracted a portion of the tender to another person without disclosing it, the tenderer should not be penalised up to 10 percent of the value of the contract; and
  - (iii) the tenderer should not be restricted by the National Treasury from conducting any business for a period not exceeding 10 years with any organ of state; and
- (c) if it concludes, after considering the representations referred to in sub regulation (1)(b), that-
  - (i) such false information was submitted by the tenderer-
    - (aa) disqualify the tenderer or terminate the contract in whole or in part; and
    - (bb) if applicable, claim damages from the tenderer; or
  - (ii) the successful tenderer subcontracted a portion of the tender to another person without disclosing, penalise the tenderer up to 10 percent of the value of the contract.

(2) (a) An organ of state must-

- (i) inform the National Treasury, in writing, of any actions taken in terms of sub regulation (1);

- (ii) provide written submissions as to whether the tenderer should be restricted from conducting business with any organ of state; and
  - (iii) submit written representations from the tenderer as to why that tenderer should not be restricted from conducting business with any organ of state.
- (b) The National Treasury may request an organ of state to submit further information pertaining to sub-regulation (1) within a specified period.
- (3) The National Treasury must-
  - (a) after considering the representations of the tenderer and any other relevant information, decide whether to restrict the tenderer from doing business with any organ of state for a period not exceeding 10 years; and
  - (b) maintain and publish on its official website a list of restricted suppliers.

### **Circulars and guidelines**

- 15.** The National Treasury may issue-
- (a) a circular to inform organs of state of any matter pertaining to these Regulations; or
  - (b) a guideline to assist organs of state with the implementation of any provision of these Regulations.

### **Repeal of Regulations and saving**

**16.(1)** Subject to this regulation, the Preferential Procurement Regulations, 2011, published in Government Notice No R. 502 of 8 June 2011 (herein called “the 2011 Regulations), are hereby repealed with effect from the date referred to in regulation 17.

(2) Any sector designated, and minimum threshold determined for local production and content for purposes of regulation 9 of the 2011 Regulations and in force immediately before the repeal of the 2011 Regulations, are regarded as having been done under regulation 8(1) of these Regulations.

(3) Any tender advertised before the date referred to in regulation 17 must be dealt with in terms of the 2011 Regulations.

### **Short title and commencement**

**17.** These Regulations are called the Preferential Procurement Regulations, 2017 and take effect on 1 April 2017.

**FORM N: MBD4 Form**

**MBD 4**

**DECLARATION OF INTEREST**

1. No bid will be accepted from persons in the service of the state<sup>1</sup>.
2. Any person, having a kinship with persons in the service of the state, including a blood relationship, may make an offer or offers in terms of this invitation to bid. In view of possible allegations of favouritism, should the resulting bid, or part thereof, be awarded to persons connected with or related to persons in service of the state, it is required that the bidder or their authorised representative declare their position in relation to the evaluating/adjudicating authority.
- 3 In order to give effect to the above, the following questionnaire must be completed and submitted with the bid.

3.1 Full Name of bidder or his or her representative:.....

3.2 Identity Number: .....

3.3 Position occupied in the Company (director, trustee, hareholder<sup>2</sup>):.....

3.4 Company Registration Number: .....

3.5 Tax Reference Number:.....

3.6 VAT Registration Number: .....

3.7 The names of all directors / trustees / shareholders members, their individual identity numbers and state employee numbers must be indicated in paragraph 4 below.

3.8 Are you presently in the service of the state? **YES / NO**

3.8.1 If yes, furnish particulars. ....

.....

<sup>1</sup>MSCM Regulations: "in the service of the state" means to be –

- (a) a member of –
  - (i) any municipal council;
  - (ii) any provincial legislature; or
  - (iii) the national Assembly or the national Council of provinces;
- (b) a member of the board of directors of any municipal entity;
- (c) an official of any municipality or municipal entity;
- (d) an employee of any national or provincial department, national or provincial public entity or constitutional institution within the meaning of the Public Finance Management Act, 1999 (Act No.1 of 1999);
- (e) a member of the accounting authority of any national or provincial public entity; or
- (f) an employee of Parliament or a provincial legislature.

<sup>2</sup> Shareholder" means a person who owns shares in the company and is actively involved in the management of the company or business and exercises control over the company.

3.9 Have you been in the service of the state for the past twelve months? .....**YES / NO**

3.9.1 If yes, furnish particulars.....

.....  
3.10 Do you have any relationship (family, friend, other) with persons in the service of the state and who may be involved with the evaluation and or adjudication of this bid? ..... **YES / NO**

3.10.1 If yes, furnish particulars.  
.....  
.....

3.11 Are you, aware of any relationship (family, friend, other) between any other bidder and any persons in the service of the state who may be involved with the evaluation and or adjudication of this bid? ..... **YES / NO**

3.11.1 If yes, furnish particulars  
.....  
.....

3.12 Are any of the company's directors, trustees, managers, principle shareholders or stakeholders in service of the state? ..... **YES / NO**

3.12.1 If yes, furnish particulars.  
.....  
.....

3.13 Are any spouse, child or parent of the company's directors trustees, managers, principle shareholders or stakeholders in service of the state? ..... **YES / NO**

3.13.1 If yes, furnish particulars.  
.....  
.....

3.14 Do you or any of the directors, trustees, managers, principle shareholders, or stakeholders of this company have any interest in any other related companies or business whether or not they are bidding for this contract. ..... **YES / NO**

3.14.1 If yes, furnish particulars:  
.....  
.....

4. Full details of directors / trustees / members / shareholders.

Full Name	Identity Number	State Employee Number

.....  
**Signature**

.....  
**Date**

.....  
**Capacity**

.....  
**Name of Bidder**

.....

**FORM O:   BBBEE Certificate, Company Registration Documents and Other Documents**

Tenderers are to attach certified copies of the following documentation to this page:

- BBBEE Certificate
- Company Registration Documents
- Identity Documents of Company Shareholders/members.
- Proof of Registration on Central Supplier Database

**Tenderers are to note that failure to submit the above documentation may result in the non-award of other preference points during tender evaluation**

**FORM P: Joint Venture Disclosure Form**

**EMPLOYER** : Harry Gwala District Municipality  
**CONTRACT DESCRIPTION** : PLANNING AND DESIGN OF UMZIMKHULU BULK SEWER  
**CONTRACT NUMBER** : CONSTRUCTION OF UMZIMKHULU BULK SEWER OUTFALL  
HGDM 759/HGDM/2022  
**PROJECT REFERENCE NUMBER** :

- Note:
- 1) This form needs not be completed for Joint Ventures which have targeted enterprise partners.
  - 2) All the information requested must be filled in the spaces provided. If additional space is required, additional sheets may be attached.
  - 3) A copy of the joint venture agreement must be attached to this form. In order to demonstrate the targeted enterprise partner's share in the ownership, control, management responsibilities, risks and profits of the joint venture, the proposed joint venture agreement must include specific details relating to:
    - i) The contributions of capital and equipment
    - ii) Work items to be performed by the targeted enterprise partner's own forces.
    - iii) Work items to be performed under the supervision of the targeted enterprise partner.
    - iv) The commitment of management, supervisory and operative personnel employed by the targeted enterprise partner to be dedicated to the performance of the Contract.
  - 4) Copies of all written agreements between partners concerning the contract must be attached to this form including those which relate to ownership options and to restrictions/limits regarding ownership and control.
  - 5) Targeted enterprise partners must each complete an Enterprise Declaration Affidavits.

**JOINT VENTURE PARTICULARS**

Name : \_\_\_\_\_  
Postal address : \_\_\_\_\_  
Physical address : \_\_\_\_\_  
Telephone : \_\_\_\_\_ Fax \_\_\_\_\_

**IDENTITY OF EACH NON-TARGETED ENTERPRISE PARTNERS**

Name : \_\_\_\_\_  
Postal address : \_\_\_\_\_  
Physical address : \_\_\_\_\_  
Telephone : \_\_\_\_\_ Fax \_\_\_\_\_  
Contact Person : \_\_\_\_\_

(Continue as required for further non-targeted enterprise partners)

**HARRY GWALA DISTRICT MUNICIPALITY**

**CONSTRUCTION OF UMZIMKHULU BULK SEWER OUTFALL**

**CONTRACT HGDM 759/HGDM/2022**

---

Name : \_\_\_\_\_  
Postal address : \_\_\_\_\_  
Physical address : \_\_\_\_\_  
Telephone : \_\_\_\_\_ Fax \_\_\_\_\_  
Contact Person : \_\_\_\_\_

**IDENTITY OF EACH TARGETED ENTERPRISE PARTNER**

Name : \_\_\_\_\_  
Postal address : \_\_\_\_\_  
Physical address : \_\_\_\_\_  
Telephone : \_\_\_\_\_ Fax \_\_\_\_\_  
Contact Person : \_\_\_\_\_

Name : \_\_\_\_\_  
Postal address : \_\_\_\_\_  
Physical address : \_\_\_\_\_  
Telephone : \_\_\_\_\_ Fax \_\_\_\_\_  
Contact Person : \_\_\_\_\_

Name : \_\_\_\_\_  
Postal address : \_\_\_\_\_  
Physical address : \_\_\_\_\_  
Telephone : \_\_\_\_\_ Fax \_\_\_\_\_  
Contact Person : \_\_\_\_\_

**DESCRIPTION OF THE ROLE OF THE TARGETED PARTNERS IN THE JOINT VENTURE**

**OWNERSHIP OF THE JOINT VENTURE**

a) Percentage Ownership in respect of	:	Targeted Enterprises	%	Targeted Enterprises	%
b) Profit and Loss Sharing	:	Targeted Enterprises	%	Targeted Enterprises	%
c) Initial Capital Contribution	:	Targeted Enterprises	R	Targeted Enterprises	R
d) Ongoing Capital Contribution	:	Targeted Enterprises	R	Targeted Enterprises	R
e) Major Plant and Equipment Contribution	:	Targeted Enterprises		Targeted Enterprises	
		_____		_____	
		_____		_____	
		_____		_____	
		_____		_____	
		_____		_____	
		_____		_____	



**RECENT CONTRACTS EXECUTED BY PARTNERS IN THEIR OWN RIGHT OR AS PARTNERS IN OTHER JOINT VENTURES**

**Targeted Enterprise Partners**

- 1. : \_\_\_\_\_
- 2. : \_\_\_\_\_
- 3. : \_\_\_\_\_
- 4. : \_\_\_\_\_
- 5. : \_\_\_\_\_

**Non-Targeted Enterprise Partners**

- 1. : \_\_\_\_\_
- 2. : \_\_\_\_\_
- 3. : \_\_\_\_\_
- 4. : \_\_\_\_\_
- 5. : \_\_\_\_\_

**CONTROL AND PARTICIPATION IN THE JOINT VENTURE**

(Identify by name and firm those individuals who are, or will be, responsible for, and have authority to engage in the relevant management functions and policy and decision making, indicating any limitations in their authority e.g. co-signature requirements and Rand limits).

Function	Targeted Enterprise Partner		Non-Targeted Enterprise	
	Enterprise	Name of Person	Enterprise	Name of Person
Cheque Signing				
Authority to enter into contracts on behalf of the Joint Venture				
Signing, co-signing and/or collateralizing of loans				
Acquisition of lines of credit				
Acquisition of performance bonds				
Negotiating and signing labour agreements				

**HARRY GWALA DISTRICT MUNICIPALITY**

**CONSTRUCTION OF UMZIMKHULU BULK SEWER OUTFALL**

**CONTRACT HGDM 759/HGDM/2022**

---

**MANAGEMENT OF CONTRACT PERFORMANCE**

(Fill in the name and firm of the responsible person).

Function	Targeted Enterprise Partner		Non-Targeted Enterprise	
	Enterprise	Name of Person	Enterprise	Name of Person
Supervision of field operations				
Major purchasing				
Estimating				
Technical management				

**MANAGEMENT AND CONTROL OF JOINT VENTURE**

- a) Managing Partner : \_\_\_\_\_
- b) What authority does each partner have to commit or obligate the other to financial institutions, insurance companies, suppliers, subcontractors and /or other parties participating in the execution of the contemplated works?

Partner	Targeted Enterprise Status		Authority Status	
	YES	NO	YES	NO

**PERSONNEL**

- a. State the approximate number of operative personnel (by trade/ function/ discipline) needed to perform the Joint Venture work under the contract.

TRADE/FUNCTION/	Total Qty Required	Qty supplied by Targeted Enterprise	Qty supplied by non-Targeted Enterprise

- b) Name of individual who will be responsible for hiring Joint Venture employees : \_\_\_\_\_
- c) Name of individual who will be responsible for preparation of Joint venture payrolls : \_\_\_\_\_

**CONTROL AND STRUCTURE OF THE JOINT VENTURE**

Briefly describe the manner in which the Joint Venture is structured and controlled.

The undersigned warrants that he/she is duly authorized to sign this Joint Venture Disclosure Form and affirms that the foregoing statements are correct and include all material information necessary to identify and explain the terms and operations of the Joint Venture and the intended participation of each partner in the undertaking.

The undersigned further covenants and agrees to provide the Employer with complete and accurate information regarding actual Joint Venture work and the payment therefore, and any proposed changes in any provisions of the Joint Venture agreement, and to permit the audit and examination of the books, records, and files of the Joint Venture, or those of each partner relevant to the Joint Venture, by duly authorized representatives of the Employer.

Signature : \_\_\_\_\_  
Name : \_\_\_\_\_  
Duly authorised to sign on behalf of : \_\_\_\_\_  
Address : \_\_\_\_\_  
Telephone : \_\_\_\_\_  
Fax : \_\_\_\_\_  
Date : \_\_\_\_\_

**PLANNING AND DESIGN OF UMZIMKHULU BULK SEWER OUTFALL**

**CONTRACT No. HGDM 759/HGDM/2022**

**CONSTRUCTION OF UMZIMKHULU BULK SEWER OUTFALL**

**PART T2.2: RETURNABLE DOCUMENTS THAT WILL BE  
INCORPORATED INTO THE CONTRACT**

**INDEX**

FORM Q: .....	Schedule of Construction Plant & Equipment	<b>RD46</b>
FORM R: Schedule of Proposed Sub-Contractors .....		<b>RD47</b>
FORM S: Record of Addenda to Tender Documents .....		<b>RD48</b>
FORM T: Key Personnel .....		<b>RD49</b>
FORM U: Rates for Special Materials .....		<b>RD51</b>
FORM V: Contractor's Health and Safety Declaration .....		<b>RD52</b>
FORM W: UIF registration Certificate .....		<b>RD54</b>
FORM X: Certificate of Municipal Services .....		<b>RD55</b>

**FORM Q: Schedule of Construction Plant & Equipment**

The following are lists of major Construction Plant and Equipment that I / We presently own or Lease and will have available for this contract if my / our tender is accepted. Tenderer shall submit a certificate of ownership / title / registration document to prove ownership.

- (a) **Details of major equipment that is owned by me / us and immediately available for this contract.**

DESCRIPTION ( <i>type, size, capacity etc</i> )	QUANTITY	YEAR OF MANUFACTURE

*Attach additional pages if more space is required*

- (b) **Details of major Plant & Equipment that will be hired, or acquired for this contract if my / our tender is accepted**

DESCRIPTION ( <i>type, size, capacity etc</i> )	QUANTITY	HOW ACQUIRED	
		HIRE/ BUY	SOURCE

*Attach additional pages if more space is required*

SIGNATURE: .....  
 (of person authorised to sign on behalf of the Tenderer)

DATE: .....

**FORM R: Schedule of Proposed Sub-Contractors**

I/We hereby notify you that it is my/our intention to employ the following Sub-Contractors for work in this contract.

NAMES AND ADDRESSES OF PROPOSED SUBCONTRACTORS	NATURE AND EXTENT OF WORK TO BE SUBCONTRACTED	PREVIOUS EXPERIENCE WITH SUBCONTRACTOR OR RECENT WORK EXECUTED BY THE SUB-CONTRACTOR
..... ..... .....		
..... ..... .....		
..... ..... .....		
..... ..... .....		
..... ..... .....		
..... ..... .....		
..... ..... .....		

**SIGNATURE:** .....  
*(of person authorised to sign on behalf of the Tenderer)*

**DATE:** .....

**FORM S: Record of Addenda to Tender Documents**

We confirm that the following communications received from the Engineer before the submission of this tender offer, amending the tender documents, have been taken into account in this tender offer:

	Date	Title or Details
1		
2		
3		
4		
5		
6		
7		
8		
9		
10		

Attach additional pages if more space is required.

Signed: ..... Date: .....

Name: ..... Position: .....

SIGNATURE: ..... DATE: .....  
*(of person authorised to sign on behalf of the Tenderer)*

**FORM T: Key Personnel**

Tenderers shall provide details of the Site Agent(s) and General Foreman's experience in work of a similar nature to that for which their tender is submitted.

Failure to complete this schedule may result in the tender not being considered.

a. Contracts Manager

<b>CONTRACTS MANAGER</b>	<b>NAME:.....</b>			
<b>CONTRACT &amp; CLIENT</b>	<b>NATURE OF WORK</b>	<b>POSITION HELD</b>	<b>VALUE OF WORK</b>	<b>YEAR COMPLETED</b>

b. Site Agent

<b>SITE AGENT</b>	<b>NAME:.....</b>			
<b>CONTRACT &amp; CLIENT</b>	<b>NATURE OF WORK</b>	<b>POSITION HELD</b>	<b>VALUE OF WORK</b>	<b>YEAR COMPLETED</b>

c. Foreman

<b>GENERAL FOREMAN</b>	<b>NAME:.....</b>			
<b>CONTRACT &amp; CLIENT</b>	<b>NATURE OF WORK</b>	<b>POSITION HELD</b>	<b>VALUE OF WORK</b>	<b>YEAR COMPLETED</b>

SIGNATURE: .....  
*(of person authorised to sign on behalf of the Tenderer)*

DATE: .....



**HARRY GWALA DISTRICT MUNICIPALITY**

**CONSTRUCTION OF UMZIMKHULU BULK SEWER OUTFALL**

**CONTRACT HGDM 759/HGDM/2022**

---

**Tenderers to attach CV of the following proposed site staff:**

- 1. Site Agent**
- 2. Foreman**
- 3. Contracts Manager**



**FORM V: Contractor's Health and Safety Declaration**

In terms of Clause 4(4) of the OHS Act 1993 Construction Regulations 2003 (referred to as "the Regulations" hereafter), a Contractor may only be appointed to perform construction work if the Employer is satisfied that the Contractor has the necessary competencies and resources to carry out the work safely in accordance with the Occupational Health and Safety Act No 85 of 1993 and the OHS Act 1993 Construction Regulations 2003.

To that effect a person duly authorised by the tenderer must complete and sign the declaration hereafter in detail.

**Declaration by Tenderer**

1. I the undersigned hereby declare and confirm that I am fully conversant with the Occupational Health and Safety Act No 85 of 1993 (as amended by the Occupational Health and Safety Amendment Act No 181 of 1993), and the OHS Act 1993 Construction Regulations 2003.
2. I hereby declare that my company / enterprise has the competence and the necessary resources to safely carry out the construction work under this contract in compliance with the Construction Regulations and the Employer's Health and Safety Specifications.
3. I hereby undertake, if my tender is accepted, to provide a sufficiently documented Health and Safety Plan in accordance with Regulation 5(1) of the Construction Regulations, approved by the Employer or his representative, before I will be allowed to commence with construction work under the contract. I hereby agree that my company/enterprise will not have a claim for compensation for delay or extension of time because of my failure to obtain the necessary approval for the said safety plan.
4. I confirm that copies of my company's approved Health and Safety Plan, the Employer's Safety Specifications as well as the OHS Act 1993 Construction Regulations 2003 will be provided on site and will at all times be available for inspection by the Contractor's personnel, the Employer's personnel, the Engineer, visitors, and officials and inspectors of the Department of Labour.
5. I hereby confirm that adequate provision has been made in my tendered rates and prices in the bill of quantities to cover the cost of all resources, actions, training and all health and safety measures envisaged in the OHS Act 1993 Construction Regulations 2003, including the cost for specific items that may be scheduled in the bill of quantities.
6. I hereby confirm that I will be liable for any penalties that may be applied by the Employer in terms of the said Regulations for failure on my part to comply with the provisions of the Act and the Regulations as set out in Regulation 30 of the Regulations.
7. I agree that my failure to complete and execute this declaration to the satisfaction of the Employer will mean that I am unable to comply with the requirements of the OHS Act 1993 Construction Regulations 2003, and accept that my tender will be prejudiced and may be rejected at the discretion of the Employer.
8. I am aware of the fact that, should I be awarded the contract, I must submit the notification required in terms of Regulation 3 of the OHS Act 1993 Construction Regulations 2003 (*example attached hereafter*) before I will be allowed to proceed with any work under the contract.

SIGNATURE: ..... DATE: .....  
(of person authorised to sign on behalf of the Tenderer)

**PRO FORMA NOTIFICATION FORM IN TERMS OF THE OCCUPATIONAL HEALTH AND  
SAFETY ACT 1993 , CONSTRUCTION REGULATIONS 2003**

***[In terms of Regulation 3 of the Construction Regulations 2003, the successful Tenderer must complete and forward this form prior to commencement of work to the office of the Department of Labour.]***

1. (a) Name and postal address of Contractor: .....
- (b) Name of Contractor's contact person: .....  
Telephone number: .....
2. Contractor's compensation registration number: .....
3. (a) Name and postal address of client: .....
- (b) Name of client's contact person or agent:.....  
Telephone number .....
4. (a) Name and postal address of designer(s) for the project: .....
- (b) Name of designer's contact person: .....  
Telephone number .....
5. Name of Contractor's construction supervisor on site appointed in terms of  
Regulation 6(1): .....  
Telephone number: .....
6. Name/s of Contractor's sub-ordinate supervisors on site appointed in terms of regulation 6(2).  
.....
7. Exact physical address of the construction site or site office: .....
8. Nature of the construction work: .....
9. Expected commencement date: .....
10. Expected completion date: .....
11. Estimated maximum number of persons on the construction site: .....
12. Planned number of subcontractors on the construction site accountable to Contractor: .....
13. Name(s) of subcontractors already chosen: .....

SIGNED BY:

CONTRACTOR:..... DATE:.....  
CLIENT:..... DATE:.....

**FORM W: UIF Registration Certificate**

*Tenderers to attach copy of UIF Registration Certificate*

**HARRY GWALA DISTRICT MUNICIPALITY**

**CONSTRUCTION OF UMZIMKHULU BULK SEWER OUTFALL**

**CONTRACT HGDM 759/HGDM/2022**

---

**FORM X: Certificate of Municipal Services**

Information required in terms of the Harry Gwala District Municipality's Supply Chain Management Policy. Latest municipal services account statement must be attached.

<b>Tender Number:</b> <b>HGDM 759/HGDM/2022</b>
<b>Name of the Tenderer:</b> _____

**FURTHER DETAILS OF THE BIDDER/S: Proprietor / Director(s) / Partners, etc:**

Physical Business address of the Bidder	Municipal Account Number(s)

If there is not enough space for all the names, please attach the additional details to the Tender document.

Name of Director / Member / Partner	Identity Number	Physical <b>residential</b> address of Director / Member / Partner	Municipal Account number(s)

I, \_\_\_\_\_, the undersigned,  
*(full name in block letters)*

**certify that the information furnished on this declaration form is correct and that I/we have no undisputed commitments for municipal services towards a municipality or other service provider in respect of which payment is overdue for more than 30 days.**

\_\_\_\_\_  
Signature

THUS DONE AND SIGNED for and on behalf of the Bidder / Contractor

at \_\_\_\_\_ on the \_\_\_\_\_ day of \_\_\_\_\_ 2020

HARRY GWALA DISTRICT MUNICIPALITY

CONSTRUCTION OF UMZIMKHULU BULK SEWER OUTFALL

CONTRACT HGDM 759/HGDM/2022

---

Please note:

Even if the requested information is not applicable to the Bidder, the table above should be endorsed NOT APPLICABLE and THIS DECLARATION MUST STILL BE SIGNED.

**MUNICIPAL SERVICES STATEMENT**

*Tenderers are to attach the latest statement (not more than 3 months old) from the municipality where the Tenderer receives municipal services*

**FORM Y: Quality Management System(Quality Assurance Plan & Control  
Procedures)**

Tenderer must submit proof of quality management system that they use in the conduct of their business .  
and construction processes.

**Certified Quality Management System**

Please attach ISO 90001 certificate by a certifying body e.g. South African National Standards or other  
recognised certifying bodies.

**OR**

**Internal / Own Quality Management System**

Attach an abridged version / summary version of own quality document.

Signed: ..... Date: .....

Name: ..... Position: .....

SIGNATURE: ..... DATE: .....  
*(of person authorised to sign on behalf of the Tenderer)*



**UMZIMKHULU BULK SEWER**  
**CONTRACT HGDM 759/HGDM/2022**  
**CONSTRUCTION OF UMZIMKHULU BULK SEWER OUTFALL**  
**PART C1: AGREEMENTS AND CONTRACT DATA**

**INDEX**

<b>PART C1: AGREEMENTS AND CONTRACT DATA .....</b>	<b>C2</b>
C1.1 Form of Offer and Acceptance .....	C2
A: Offer .....	C2
B: Acceptance .....	C3
C: Schedule of Deviations .....	C4
D: Confirmation of Receipt .....	C6
<b>PART C1.2 CONTRACT DATA .....</b>	<b>C7</b>
C1.2.1 General Conditions of Contract .....	C7
C1.2.2 Contract Data Provided by Employer .....	C8
C1.2.3 Data Provided by the Contractor .....	C10
C1.3: PERFORMANCE OF GUARANTEE .....	C12
C1.4: DISCLOSURE STATEMENT .....	C15
C1.5: AGREEMENT IN TERMS OF SECTION 37(2) OF THE OCCUPATIONAL HEALTH AND SAFETY ACT No 85 OF 1993 .....	C16
C1.6: ADJUDICATION BOARD MEMBER AGREEMENT .....	C18

## PART C1: AGREEMENTS AND CONTRACT DATA

### C1.1 Form of Offer and Acceptance A:

#### Offer

The Employer, identified in the Acceptance signature block, has solicited offers to enter into a Contract for the procurement of: **CONTRACT HGDM 759/HGDM/2022**

#### CONSTRUCTION OF UMZIMKHULU BULK SEWER OUTFALL

The Tenderer, identified in the Offer signature block, has examined the documents listed in the Tender Data and addenda thereto as listed in the returnable schedules, and by submitting this offer has accepted the conditions of tender.

By the representative of the tenderer, deemed to be duly authorized, signing this part of this form of offer and acceptance, the tenderer offers to perform all of the obligations and liabilities of the contractor under the contract including compliance with all its terms and conditions according to their true intent and meaning for an amount to be determined in accordance with the conditions of contract identified in the contract data.

#### THE OFFERED TOTAL PRICE INCLUSIVE OF VALUE ADDED TAX (VAT) IS

.....  
.....  
..... Rand (in words);  
R .....(in figures),

This offer may be accepted by the employer by signing the Acceptance part of this Form of Offer and Acceptance and returning one copy of this document to the tenderer before the end of the period of validity stated in the tender data, whereupon the tenderer becomes the party named as the contractor in the conditions of contract identified in the contract data.

**Signature:** .....

**Name: (in capitals)** .....

**Capacity:** .....

**Name of Tenderer (organisation):** .....

**Address:** .....  
.....  
.....

Tel: ..... Fax: .....

#### Witness:

Signature: ..... Name: .....

Date: ..... CIDB Registration N<sup>o</sup>:.....

**HARRY GWALA DISTRICT MUNICIPALITY**

**CONSTRUCTION OF UMZIMKHULU BULK SEWER OUTFALL**

**HGDM 759/HGDM/2022**

---

**B: Acceptance**

By signing this part of this form of offer and acceptance, the employer identified below accepts the tenderer's offer. In consideration thereof, the Employer shall pay the Contractor the amount due in accordance with the conditions of contract identified in the contract data. Acceptance of the tenderer's offer shall form an agreement, between the employer and the tenderer upon the terms and conditions contained in this agreement and in the contract that is the subject of this agreement.

The terms of the contract, are contained in

- Part C1 Agreements and contract data, (which includes this agreement)
- Part C2 Pricing data
- Part C3 Scope of work
- Part C4 Site information

and drawings and documents or parts thereof, which may be incorporated by reference into Parts C1 to C4 above.

Deviations from and amendments to the documents listed in the tender data and any addenda thereto as listed in the tender schedules as well as any changes to the terms of the offer agreed by the tenderer and the employer during this process of offer and acceptance, are contained in the schedule of deviations attached to and forming part of this agreement. No amendments to or deviations from said documents are valid unless contained in this schedule.

The tenderer shall within two weeks after receiving a completed copy of this agreement, including the schedule of deviations (if any), contact the employer's agent (whose details are given in the contract data) to arrange the delivery of any bonds, guarantees, proof of insurance and any other documentation to be provided in terms of the conditions of contract identified in the contract data. Failure to fulfil any of these obligations in accordance with those terms shall constitute a repudiation of this agreement.

Notwithstanding anything contained herein, this agreement comes into effect on the date when the tenderer receives one fully completed original copy of this document, including the schedule of deviations (if any). Unless the tenderer (now contractor) within five working days of the date of such receipt notifies the employer in writing of any reason why he cannot accept the contents of this agreement, this agreement shall constitute a binding contract between the parties.

**Signature:** .....

**Name: (in capitals)** .....

**Capacity:** .....

**Name of Employer (organisation):** .....

**Address:** .....  
.....

**Witness:**

**Signature:** ..... **Name:** .....

**Date:** .....

**C: Schedule of Deviations**

Notes:

1. The extent of deviations from the tender documents issued by the employer prior to the tender closing date is limited to those permitted in terms of the conditions of tender.
2. A tenderer's covering letter shall not be included in the final contract document. Should any matter in such letter, which constitutes a deviation as aforesaid, become the subject of agreements reached during the process of offer and acceptance, the outcome of such agreement shall be recorded here.
3. Any other matter arising from the process of offer and acceptance either as a confirmation, clarification or change to the tender documents and which it is agreed by the Parties becomes an obligation of the contract shall also be recorded here.
4. Any change or addition to the tender documents arising from the above agreements and recorded here, shall also be incorporated into the final draft of the Contract.

**Subject** \_\_\_\_\_  
Details \_\_\_\_\_  
\_\_\_\_\_

**Subject** \_\_\_\_\_  
Details \_\_\_\_\_  
\_\_\_\_\_

**Subject** \_\_\_\_\_  
Details \_\_\_\_\_  
\_\_\_\_\_

**Subject** \_\_\_\_\_  
Details \_\_\_\_\_  
\_\_\_\_\_

**Subject** \_\_\_\_\_  
Details \_\_\_\_\_  
\_\_\_\_\_

By the duly authorised representatives signing this agreement, the employer and the tenderer agree to and accept the foregoing schedule of deviations as the only deviations from and amendments to the documents listed in the tender data and addenda thereto as listed in the tender schedules, as well as any confirmation, clarification, or changes to the terms of the offer agreed by the tenderer and the employer during this process of offer and acceptance.

It is expressly agreed that no other matter whether in writing, oral communication or implied during the period between the issue of the tender documents and the receipt by the tenderer of a completed signed

**HARRY GWALA DISTRICT MUNICIPALITY**  
**CONSTRUCTION OF UMZIMKHULU BULK SEWER OUTFALL**  
**HGDM 759/HGDM/2022**

---

copy of this agreement shall have any meaning or effect in the contract between the parties arising from this Agreement.

**FOR THE TENDERER:**

**Signature:** .....

**Name:** .....

**Capacity:** .....

**Tenderer:** *(Name and address of organisation)* .....

.....

**Witness :**

**Signature:** .....

**Name:** .....

**Date:** .....

**FOR THE EMPLOYER**

**Signature:** .....

**Name:** .....

**Capacity:** .....

**Employer:** *(Name and address of organisation)* .....

.....

**Witness :**

**Signature:** .....

**Name:** .....

**Date:** .....

**D: Confirmation of Receipt**

The Tenderer, (now Contractor), identified in the Offer part of this Agreement hereby confirms receipt from the Employer, identified in the Acceptance part of this Agreement, of one fully completed original copy of this Agreement, including the Schedule of Deviations (if any) today:

The .....(day)

of .....(month)

20.....(year)

at .....(place)

**For the Contractor:**

.....  
Signature

.....  
Name

.....  
Capacity

**Signature and Name of Witness:**

.....  
Signature

.....  
Name

## **PART C1.2      CONTRACT DATA**

### **C1.2.1          General Conditions of Contract**

The General Conditions of Contract for Construction Works (3<sup>RD</sup> Edition 2015) published by the South African Institution of Civil Engineering, Private Bag X200, Halfway House, 1685 is applicable to this contract.

Copies of these conditions of contract may be obtained from the South African Institution of Civil Engineering (Tel 011- 805 5947, Fax: 011 – 805 5971).

The Contract Data referred to in the General Conditions of Contract follow, with the Data to be completed Employer furnished. The Tenderer is to provide his details in the spaces provided.

**C1.2.2 Contract Data Provided by Employer****CONSTRUCTION OF UMZIMKHULU BULK SEWER OUTFALL**

	<b>GCC 2015 Clause</b>	
Defects Liability Period	1.1.1.13	12 months
Name of Employer	1.1.1.15	Harry Gwala District Municipality
Address of Employer	1.2.1.2	40 main Street, Ixopo, 3276 Harry Gwala District Municipality P O Box X501 IXOPO 3276 Email address: GqibaD@harrygwalm.gov.za Tel N°: +27 39 834 8700 Fax N°: +27 39 834 2259
Name of Engineer	1.1.1.16	Zimile Consulting Engineers
Address of the Engineer	1.2.1.2	Zimile Consulting Engineers 76 Hope Street Kokstad 4700 Email : <a href="mailto:info@zimile.co.za">info@zimile.co.za</a> Tel : 039 940 6729
Pricing Strategy	1.1.1.26	Re-measurement Contract
Subcontracting	4.4.7	Add the following new Clause: <b>The contractor will be required to subcontract up to a maximum of 30% of the work to local subcontractors. The work to be subcontracted will be agreed upon with the Employer</b>
Documentation Required Before Commencement of Construction Works	5.3.1	Health and Safety File (Refer to Clause 4.3) Initial Programme (Refer to Clause 5.6) Security (Refer to Clause 6.2) Insurances (Refer to Clause 8.6)
Time to Submit the Documentation Before Commencement with the Works	5.3.2	14 days after commencement date
Non-working Days	5.8.1	Sundays



HARRY GWALA DISTRICT MUNICIPALITY

CONSTRUCTION OF UMZIMKHULU BULK SEWER OUTFALL

HGDM 759/HGDM/2022

	GCC 2015 Clause	
Special Non working days	5.8.1	1. Public Holidays 2. The year-end break commencing on the first day, working day, after 15 December and ending on the first Tuesday after 5 January of the next year
Penalty for Failing to Complete the Works	5.13.1	R1, 000.00 per calendar day
The Latent Defect Period	5.16.3	10 years
Contract Price Adjustment Schedule	6.8.2	x = 0,15 a = 0,20 b = 0,20 c = 0,50 d = 0,10  'L' shall be the "Weighted Average" index, P0141, Table A  'F' shall be the "Fuel (Diesel)" index given in P0142.1 Table 12 for KwaZulu Natal
Area for Producer Price Index		Pietermaritzburg
Base Month		Month before closing date of Tenders
Price Adjustments for Special Materials	6.8.3	Price adjustments for variations in the costs special materials are allowed
The Percentage Advance on Materials not yet Built into the Permanent Works	6.10.1.5	80% (subject to provision of Indemnity for Materials on Site)
Limit of Retention Money	6.10.3	10% of Contract Sum
Value of Plant and Material Supplied by Employer to be included in the insurance sum	8.6.1.1.2	Nil
Amount to cover professional fees for repairing damage and loss	8.6.1.1.3	14% of Repair Amount
Limit of Indemnity for Liability Insurance	8.6.1.3	R10, 000, 000.00 for each and every claim
Dispute Resolution	10.5.1	Standing Adjudication Board
Number of Adjudication Board Members to be Appointed	10.5.3	One
Dispute Determination	10.7.1	Dispute Determination shall be by Arbitration

SIGNATURE OF TENDERER: .....

DATE: .....

**C1.2.3 Data Provided by the Contractor**

	<b>GCC 2015 Clause</b>																			
Name of Contractor	1.1.1.9	.....																		
Address of Contractor (Physical and Postal)	1.2.1.2	..... ..... ..... .....																		
Tel:		.....																		
Fax:		.....																		
Email:		.....																		
Time for Achieving Practical Completion:	1.1.1.14	18 months																		
Security to be Provided by Contractor	6.2.1	Refer to Table Below																		
<table border="1"> <thead> <tr> <th>Type of Security</th> <th>Contractor's Choice (Indicate "YES" or "NO")</th> </tr> </thead> <tbody> <tr> <td><i>Is Value Added Tax included in the Contract Sum and value of Works for calculating percentages?</i></td> <td></td> </tr> <tr> <td>Cash deposit of .....% of the Contract Sum</td> <td></td> </tr> <tr> <td>Performance Guarantee of .....% of the Contract Sum</td> <td></td> </tr> <tr> <td>Retention of .....% of the value of Works</td> <td></td> </tr> <tr> <td>Cash Deposit of .....% of the Contract Sum plus Retention of .....% of the value of Works</td> <td></td> </tr> <tr> <td>Performance Guarantee of .....% of the Contract Sum plus Retention of .....% of the value of Works</td> <td></td> </tr> <tr> <td></td> <td></td> </tr> <tr> <td></td> <td></td> </tr> </tbody> </table>			Type of Security	Contractor's Choice (Indicate "YES" or "NO")	<i>Is Value Added Tax included in the Contract Sum and value of Works for calculating percentages?</i>		Cash deposit of .....% of the Contract Sum		Performance Guarantee of .....% of the Contract Sum		Retention of .....% of the value of Works		Cash Deposit of .....% of the Contract Sum plus Retention of .....% of the value of Works		Performance Guarantee of .....% of the Contract Sum plus Retention of .....% of the value of Works					
Type of Security	Contractor's Choice (Indicate "YES" or "NO")																			
<i>Is Value Added Tax included in the Contract Sum and value of Works for calculating percentages?</i>																				
Cash deposit of .....% of the Contract Sum																				
Performance Guarantee of .....% of the Contract Sum																				
Retention of .....% of the value of Works																				
Cash Deposit of .....% of the Contract Sum plus Retention of .....% of the value of Works																				
Performance Guarantee of .....% of the Contract Sum plus Retention of .....% of the value of Works																				
Price variation of special materials*	6.8.3	.....																		

Type of Special Material	Unit	Rate or Price*
Rate or price for base month of*	6.8.2	.....

***Tenderers are to note that failure to provide a time for completion of the contract will invalidate the tender offer.***

**\* Delete inapplicable**

Signature: .....

Name of Signatory: .....

Date: .....

Name of Tenderer .....

**C1.3: PERFORMANCE GUARANTEE**

For use with the General Conditions of Contractor for Construction Works, Third Edition, 2015.

**GUARANTOR DETAILS AND DEFINITIONS**

“Guarantor“ means: .....

Physical Address: .....

“Employer” means: .....

“Contractor” means: .....

“Engineer” means: .....

“Works” means: .....

“Site” means: .....

“Contract” means: The agreement made in terms of the Form of Offer and Acceptance and such amendments or additions to the Contract as may be agreed in writing between the parties.

“Contract Sum” means: The accepted amount inclusive of tax of R .....  
Amount in words: .....

.....

“Expiry Date” means: .....

**CONTRACT DETAILS**

Engineer issues; Interim Payment Certificates, Final Payment Certificate and the Certificate Completion of the Works as defined in the Contract.

**PERFORMANCE GUARANTEE**

1. The Guarantor’s liability shall be limited to the amount of the Guaranteed Sum.
2. The Guarantor’s period of liability shall be from and including the date of issue of this Performance Guarantee and up to and including the Expiry Date or the date of issue by the Engineer of the Certificate of Completion of the Works or the date of payment in full of the Guaranteed Sum, whichever occurs first. The Engineer and / or the Employer shall advise the Guarantor in writing of the date on which the Certificate of Completion of the Works has been issued.
3. The Guarantor hereby acknowledges that:
  - 3.1 any reference in this Performance Guarantee to the Contract is made for the purpose of convenience and shall not be construed as any intention whatsoever to create an accessory obligation or any intention whatsoever to create suretyship;
  - 3.2 its obligation under this Performance Guarantee is restricted to the payment of money.
4. Subject to the Guarantor’s maximum liability referred to in 1, the Guarantor hereby undertakes to pay the Employer the sum certified upon receipt of the documents identified in 4.1 to 4.3:

- 4.1 A copy of a first written demand issued by the Employer to the Contractor stating that payment of a sum certified by the Engineer in an interim or Final Payment Certificate has not been made in terms of the Contract and failing such payment within seven (7) calendar days, the Employer intends to call upon the Guarantor to make payment in terms of 4.2;
- 4.2 A first written demand issued by the Employer to the Guarantor at the Guarantor's physical address with a copy to the Contractor stating that a period of seven (7) days has elapsed since the first written demand in terms of 4.1 and the sum certified has still not been paid;
- 4.3 A copy of the aforesaid payment certificate which entitles the Employer to receive payment in terms of the Contract of the sum certified in 4.
5. Subject to the Guarantor's maximum liability referred to in 1, the Guarantor undertakes to pay to the Employer the Guaranteed Sum or the full outstanding balance upon receipt of a first written demand from the Employer to the Guarantor at the Guarantor's physical address calling up this Performance Guarantee, such demand stating that:
  - 5.1 the contract has been terminated due to the Contractor's default and that this Performance Guarantee is called up in terms of 5; or
  - 5.2 a provisional or final sequestration or liquidation court order has been granted against the Contractor and that the Performance Guarantee is called up in terms of 5; and
  - 5.3 the aforesaid written demand is accompanied by a copy of the notice of termination and/ or the provisional/ final sequestration and / or the provisional liquidation court order.
6. It is recorded that the aggregate amount of payments required to be made by the Guarantor in terms of 4 and 5 shall not exceed the Guarantor's maximum liability in terms of 1.
7. Where the Guarantor has made payment in terms of 5, the Employer shall upon the date of issue of the Final Payment Certificate submit an expense account to the Guarantor showing how all monies received in terms of this Performance Guarantee have been expended and shall refund to the Guarantor any resulting surplus. All monies refunded to the Guarantor in terms of this Performance Guarantee shall bear interest at the prime overdraft rate of the Employer's bank compounded monthly and calculated from the date payment was made by the Guarantor to the Employer until the date of refund.
8. Payment by Guarantor in terms of 4 or shall be made within seven (7) calendar days upon receipt of the first written demand to the Guarantor.
9. Payment of the Guarantor in terms of 5 will only be made against the return of the original Performance Guarantee by the Employer.
10. The employer shall have the absolute right to arrange his affairs with the Contractor in any manner which the Employer may deem fit and the Guarantor shall not have the right to claim his release from his Performance Guarantee on account of any conduct alleged to the prejudicial to the Guarantor.
11. The Guarantor chooses the physical address as stated above for the service of all notices for all purposes in connection herewith.

- 12. This Performance Guarantee is neither negotiable nor transferable and shall expire in terms of 2, where after no claims will be considered by the Guarantor. The original of this Guarantee shall be returned to the Guarantor after it has expired.
- 13. This Performance Guarantee, with the required demand notices in terms of 4 or 5, shall be regarded as liquid document for the purposes of obtaining a court order.
- 14. Where this Performance Guarantee is issued in the Republic of South Africa the Guarantor hereby consents in terms of Section 45 of the Magistrate's Courts Act No 32 of 1994, as amended, to the jurisdiction of the Magistrate's Court of any district having jurisdiction in terms of Section 28 of the said Act, notwithstanding that the amount of the claim may exceed the jurisdiction of the Magistrate's Court.

Signed at .....

Date .....

Guarantor's signatory (1) .....

Capacity .....

Guarantor's signatory (2) .....

Capacity .....

Witness signatory (1) .....

Witness signatory (2) .....

**C1.4: DISCLOSURE STATEMENT**

(Date).....

Contract: (Name).....

Contractor: (Name).....

Employer: (Name).....

Engineer: (Name).....

Dear Sirs,

I am willing and available to serve as (ad-hoc/standing) Adjudication Board Member in the above-mentioned Contract.

In accordance with the General Conditions of Contract for Construction Works Adjudication Board Rules relating to disclosure statements by selected or nominated persons to the adjudication, I hereby state that:

1. I shall act with complete impartiality and know of nothing at this time, which could affect my impartiality.
2. I had no previous involvement with this project.
3. I do not have any financial interest in this project.
4. I am not currently employed by the Contractor, Employer or Engineer.
5. I do not have any financial connections with the Contractor, Employer or Engineer.
6. I do not have or not have had a personal relationship with any authoritative member of the Contractor, Employer or the Engineer which could affect my impartiality.
7. I undertake to immediately disclose to the parties any changes in the above position which could affect my impartiality or be perceived to affect the same.

*Should there be any deviation from the foregoing statements, details shall be given hereunder.*

.....  
.....  
.....

I further declare that I am experienced in the work which is carried out under the Contract and in interpreting contract documentation.

Name in full: .....

Signature: .....

**C1.5: AGREEMENT IN TERMS OF SECTION 37(2) OF THE OCCUPATIONAL HEALTH AND SAFETY ACT No 85 OF 1993**

THIS AGREEMENT is made between **HARRY GWALA DISTRICT MUNICIPALITY** (hereinafter called the EMPLOYER) of the one part, herein represented by: .....

.....  
in his capacity as: .....

AND: .....

(Hereinafter called the CONTRACTOR) of the other part, herein represented by.....

.....  
in his capacity as: .....

duly authorized to sign on behalf of the Contractor.

**WHEREAS** the CONTRACTOR is the Mandatory of the EMPLOYER in consequence of an agreement between the CONTRACTOR and the EMPLOYER in respect of

CONTRACT No: ..... (CONTRACT TITLE)

.....  
for the construction, completion and maintenance of the works;

AND WHEREAS the EMPLOYER and the CONTRACTOR have agreed to enter into an agreement in terms of the provisions of Section 37(2) of the Occupational Health and Safety Act No 85 of 1993, as amended by OHS Act Amendment Act No 181/1993 (hereinafter referred to as the ACT);

**NOW THEREFORE** the parties agree as follows:

1. The CONTRACTOR undertakes to acquaint the appropriate officials and employees of the CONTRACTOR with all relevant provisions of the ACT and the regulations promulgated in terms thereof.
2. The CONTRACTOR undertakes to fully comply with all relevant duties, obligations and prohibitions imposed in terms of the ACT and Regulations: Provided that should the EMPLOYER have prescribed certain arrangements and procedures that same shall be observed and adhered to by the CONTRACTOR, his officials and employees. The CONTRACTOR shall bear the onus of acquainting himself/herself/itself with such arrangements and procedures.
3. The CONTRACTOR hereby accepts sole liability for such due compliance with the relevant duties, obligations, prohibitions, arrangements and procedures, if any, imposed by the ACT and Regulations, and the CONTRACTOR expressly absolves the EMPLOYER and the Employer's CONSULTING ENGINEERS from being obliged to



**HARRY GWALA DISTRICT MUNICIPALITY**

**CONSTRUCTION OF UMZIMKHULU BULK SEWER OUTFALL**

**HGDM 759/HGDM/2022**

---

comply with any of the aforesaid duties, obligations, prohibitions, arrangements and procedures in respect of the work included in the contract.

4. The CONTRACTOR agrees that any duly authorized officials of the EMPLOYER shall be entitled, although not obliged, to take such steps as may be necessary to ensure that the CONTRACTOR has complied with his undertakings as more fully set out in paragraphs 1 and 2 above, which steps may include, but shall not be limited to, the right to inspect any appropriate site or premises occupied by the CONTRACTOR, or to take such steps it may deem necessary to remedy the default of the CONTRACTOR at the cost of the CONTRACTOR.
  
5. The CONTRACTOR shall be obliged to report forthwith to the EMPLOYER any investigation, complaint or criminal charge which may arise as a consequence of the provisions of the ACT and Regulations, pursuant to work performed in terms of this agreement, and shall, on written demand, provide full details in writing of such investigation, complaint or criminal charge.

Thus, signed at ..... for and on behalf of the  
**CONTRACTOR**

on this the ..... day of ..... 20.....

SIGNATURE: .....

NAME AND SURNAME: .....

CAPACITY: .....

WITNESSES: 1. ....

2. ....

Thus, signed at ..... for and on behalf of the  
**EMPLOYER**

on this the ..... day of ..... 20.....

SIGNATURE: .....

NAME AND SURNAME: .....

CAPACITY: .....

WITNESSES: 1. ....

2. ....

**C1.6: ADJUDICATION BOARD MEMBER AGREEMENT**

This Agreement is entered into between:

Adjudication Board Member: *(Name, physical address, postal address, email address, fax number, telephone number and mobile number)*.....  
.....  
.....

Contractor: *(Name, physical address, postal address, email address, fax number, telephone number and mobile number)*.....  
.....  
.....

Employer: *(Name, physical address, postal address, email address, fax number, telephone, number and mobile number)*.....  
.....  
.....

The contractor and the Employer will hereinafter be collectively referred to as “the Parties”.

The Parties entered into a Contract for .....  
*(name of project)* which provides that a dispute under or in connection with the General Conditions of Contract for Construction Works, Second Edition, 2010, must be referred to *(ad-hoc adjudication/standing adjudication\*\*)*.

The undersigned natural person has been appointed to serve as Adjudication Board Member and together with the undersigned Parties agree as follows:

1. The Adjudication Board Member accepts to perform his duties in accordance with the terms of the Contract, the General Conditions of Contract for Construction Works Adjudication Board Rules and this Agreement.
2. The Adjudicator undertakes to remain independent and impartial of the Contractor, Employer and Engineer for the duration of the Adjudication Board proceedings.
3. The Adjudication Board Member agrees to serve for the duration of the Adjudication Board proceedings.
4. The Parties may at any time, without cause and with immediate effect, jointly terminate this Agreement.

**HARRY GWALA DISTRICT MUNICIPALITY**

**CONSTRUCTION OF UMZIMKHULU BULK SEWER OUTFALL**

**HGDM 759/HGDM/2022**

---

5. Unless the Parties agree, the Adjudication Board Member shall not act as arbitrator or representative of either Party in any subsequent proceedings between the Parties under the Contract. No Party may call the Adjudication Board Member as a witness in any such subsequent proceedings.
6. The standing Adjudication Board's duties shall end upon the Adjudication Board Member(s) receiving notice from the Parties of their joint decision to disband the Adjudication Board.
7. The Adjudication Board Member shall be paid in respect of time spent upon or in connection with the adjudication including time spent travelling :
  - a. A monthly retainer of R.....(*amount*) for .....(*number*) of months, and /or
  - b. A daily fee of R.....(*amount*) based on a .....(*number*) hour day, and /or
  - c. A hourly fee of R.....(*amount*), and /or
  - d. A non- recurrent appointment fee of R.....(*amount*) which shall be accounted for in the final sums payable.
8. The Adjudication Board Member's expenses incurred in adjudication work shall be reimbursed at cost.

Upon submission of an invoice for fees and expenses to the Parties, the (*Contractor/ Employer\*\**) shall pay the full amount within 28 days of receipt of the invoice and he shall be reimbursed by the other party by half the amount so that the fees and expenses are borne equally by the Parties. Late payment of such invoice shall attract the interest at prime plus 3% points compounded monthly at the prime rate changed by the Adjudication Board Member's bank.

This Agreement is entered into by:

**HARRY GWALA DISTRICT MUNICIPALITY**  
**CONSTRUCTION OF UMZIMKHULU BULK SEWER OUTFALL**  
**HGDM 759/HGDM/2022**

---

Contractor's Signature : .....

Contractor's name : .....

Place : .....

Date : .....

Employer's signature : .....

Employer's name : .....

Place : .....

Date : .....

Adjudication Board Member's signature : .....

Adjudication Board Member's name : .....

Place : .....

Date : .....

*\*\*Delete the inapplicable party*

**UMZIMKHULU BULK SEWER**  
**CONTRACT No. HGDM 759/HGDM/2022**  
**CONSTRUCTION OF UMZIMKHULU BULK SEWER OUTFALL**

**PART C2: PRICING DATA**

**INDEX**

<b>PART C2: PRICING DATA .....</b>	<b>PD2</b>
C2.1 Pricing Instructions .....	PD2
C2.2 Schedule of Quantities .....	PD6

## PART C2: PRICING DATA

### C2.1 Pricing Instructions

- 1 The Conditions of Contract, the Contract Data, the Specifications (including the Project Specifications) and the Drawings shall be read in conjunction with the Bill of Quantities.
- 2 The Bill comprises items covering the Contractor's profit and costs of general liabilities and of the construction of Temporary and Permanent Works.

Although the Tenderer is at liberty to insert a rate of his own choosing for each item in the Bill, he should note the fact that the Contractor is entitled, under various circumstances, to payment for additional work carried out and that the Engineer is obliged to base his assessment of the rates to be paid for such additional work on the rates the Contractor inserted in the Bill. Clause 8 of each Standardized Specification, and the measurement and payment clause of each Particular Specification, read together with the relevant clauses of the Project Specifications, all set out which ancillary or associated activities are included in the rates for the specified operations

- 3 Descriptions in the Bill of Quantities are abbreviated and may differ from those in the Standardized and Project Specifications. No consideration will be given to any claim by the Contractor submitted on such a basis. The Bill has been drawn up generally in accordance with the latest issue of Civil Engineering Quantities. Should any requirement of the measurement and payment clause of the appropriate Standardized or Project Specification(s) be contrary to the terms of the Bill or, when relevant, to the Civil Engineering Quantities, the requirement of the appropriate Standardized, Project, or Particular Specification as the case may be, shall prevail
- 4 Unless stated to the contrary, items are measured net in accordance with the Drawings without any allowance having been made for waste.
- 5 The amounts and rates to be inserted in the Bill of Quantities shall be the full inclusive amounts to the Employer for the work described under the several items. Such amounts shall cover all the costs and expenses that may be required in and for the construction of the work described, and shall cover the costs of all general risks, profits, taxes (but excluding value-added tax), liabilities and obligations set forth or implied in the documents on which the Tender is based.
- 6 An amount or rate shall be entered against each item in the Bill of Quantities, whether or not quantities are stated. An item against which no amount or rate is entered will be considered to be covered by the other amounts or rates in the Bill.

The Tenderer shall also fill in a rate against the items where the words "rate only" appear in the amount column. Although no work is foreseen under these items and no quantities are consequently given in the quantity column, the tendered rates shall apply should work under these items actually be required.

Should the Tenderer group a number of items together and tender one sum for such group of items, the single tendered sum shall apply to that group of items and not to each individual item, or should he indicate against any item that full compensation for such item has been included in another item, the rate for the item included in another item shall be deemed to be nil.

The tendered rates, prices and sums shall, subject only to the provisions of the Conditions of Contract, remain valid irrespective of any change in the quantities during the execution of the Contract.

- 7 The quantities of work as measured and accepted and certified for payment in accordance with the Conditions of Contract, and not the quantities stated in the Bill of Quantities, will be used to determine payments to the Contractor. The validity of the Contract shall in no way be affected by differences between the quantities in the Bill of Quantities and the quantities certified for payment.

**Ordering of materials** are not to be based on the Bill of Quantities, but only on information issued for construction purposes.

## 8 PROVISIONAL SUM

Where Provisional sums or Prime Cost sums are provided for items in the Bill of Quantities, payments for the Work done under such items will be made accordance with Clause 6.6 of **GCC 2015 (3<sup>rd</sup> Edition) of the General Condition of Contract**. The Employer reserves the right, during the execution of the works, to adjust the stated amounts upwards or downwards according to the work actually done under the item, or the item may be omitted altogether, without affecting the validity of the Contract, such approval shall be granted by the Executive Director Infrastructure Services as delegated by the Accounting Officer.

The Tenderer shall not under any circumstances whatsoever delete or amend any of the sums inserted in the "Amount" column of the Bill of Quantities and in the Summary of the Bill of Quantities unless ordered or authorized in writing by the Employer before closure of tenders. Unauthorized changes made by the Tenderer to provisional items in the Bill of Quantities, or to the stated provisional percentages and sums in the Summary of the Bill of Quantities, will not be permissible.

## 9 CONTINGENCY

The sum provided under contingency in the Bill of Quantities is under the sole control of the Employer and may be deducted in whole or in part and shall only be expended by order of the Employer as Variation Order. The use of contingency shall be upon approval by the Executive Director Infrastructure Services as delegated by the Accounting Officer.  
Director Infrastructure Services as delegated by the Accounting Officer.

## 10 PAYMENT FOR THE LABOUR-INTENSIVE COMPONENT OF THE WORKS

Those parts of the works to be constructed using labour-intensive methods are marked in the bill of quantities with the letters LI either in a separate column or as a prefix or suffix against every item so designated. The works, or parts of the works so designated are to be constructed using labour-intensive methods only. The use of plant to provide such works, other than plant specifically provided for in the scope of work, is a deviation from the contract. The items marked with the letters LI are not necessarily an exhaustive list of all the activities which must be done by hand and this clause does not over-ride any of the requirements in the generic labour-intensive specification in the Scope of Works.

Where minimum labour intensity is specified in the design, the contractor is expected to use their initiative to identify additional activities that can be done labour-intensively in order to comply with the set minimum labour intensity targets.

Payment for items which are designated to be constructed labour-intensively (either in this schedule or in the Scope of Works) will not be made unless they are constructed using labour-intensive methods. Any unauthorised use of plant to carry out work which was to be done labour-intensively will not be condoned and any works so constructed will not be certified for payment.

## HARRY GWALA DISTRICT MUNICIPALITY

### CONSTRUCTION OF UMZIMKHULU BULK SEWER OUTFALL

#### HGDM 759/HGDM/2022

---

Any non-payment for such works shall not relieve the Contractor in any way from his obligations either in contract or in delict

#### 11. Linkage of Payment for Labour-Intensive Component of Works to Submission of Project Data

The Contractor's payment invoices shall be accompanied by labour information for the corresponding period in a format specified by the employer. If the contractor chooses to delay submitting payment invoices, labour returns shall still be submitted as per frequency and timeframes stipulated by the Employer. The contractor's invoices shall not be paid until all pending labour information has been submitted. The client may institute a penalty relating to outstanding labour information.

The following information shall be maintained on site and submitted in electronic/hard copy formats:

- Certified ID copies of all locally employed labour
- Signed Contracts between the employer and the EPWP Participants
- Attendance Registers for the EPWP Participants
- Proof of Payment of EPWP Employees
- Monthly Reporting Template as per EPWP requirements

#### 10 The units of measurement indicated in the Bill of Quantities are metric units. The following abbreviations may appear in the Bill of Quantities:

mm	=	millimetre
m	=	metre
km	=	kilometre
km-pass	=	kilometre-pass
m <sup>2</sup>	=	square metre
m <sup>2</sup> -pass	=	square metre-pass
ha	=	hectare
m <sup>3</sup>	=	cubic metre
m <sup>3</sup> -km	=	cubic metre-kilometre
kW	=	kilowatt
kN	=	kilonewton
kg	=	kilogram
t	=	ton (1 000 kg)
%	=	per cent
MN	=	meganewton
MN-m	=	meganewton-metre
PC Sum	=	Prime Cost Sum
Prov Sum	=	Provisional Sum
No.	=	number



**HARRY GWALA DISTRICT MUNICIPALITY**

**CONSTRUCTION OF UMZIMKHULU BULK SEWER OUTFALL**

**HGDM 759/HGDM/2022**

---

11 For the purposes of this Bill of Quantities, the following words shall have the meanings hereby assigned to them:

Unit : The unit of measurement for each item of work as defined in the Standardized, Project or Particular Specifications

Quantity : The number of units of work for each item

Rate : The payment per unit of work at which the Tenderer tenders to do the work

Amount : The quantity of an item multiplied by the tendered rate of the (same) item

Sum : An amount tendered for an item, the extent of which is described in the Bill of Quantities, the Specifications or elsewhere, but of which the quantity of work is not measured in units

HARRY GWALA DISTRICT MUNICIPALITY  
 UMZIMKHULU BULK SEWER  
 CONTRACT NUMBER: .....  
 CONSTRUCTION OF BULK SEWER OUTFALLS

**SCHEDULE OF QUANTITIES**

**SUMMARY OF BILL OF QUANTITIES**

SECTION	DESCRIPTION	AMOUNT
1.1	<b>Schedule 1.1: General</b> .....	
1.2	<b>Schedule 1.2: Provisional Sum and Dayworks</b> .....	
2	<b>Pipelines</b> .....	
2.1	Schedule 2.1 - Site Clearance.....	
2.2	Schedule 2.2 - Earthworks (Pipe Trenches).....	
2.3	Schedule 2.3 - Bedding (Pipes).....	
2.4	Schedule 2.4 - Sewers.....	
2.5	Schedule 2.5 - Pipe Jacking.....	
3	<b>Pumpstation, Manholes and Junction Boxes</b> .....	
3.1	Schedule 3.1 - Earthworks.....	
3.2	Schedule 3.2 - Concrete (Small works).....	
3.3	Schedule 3.3 - Precast Concrete (Structural).....	
3.4	Schedule 3.4 - Masonry works.....	
4	<b>Access Roads</b> .....	
4.1	Schedule 4.1 -Access Roads.....	
6	<b>SUB TOTAL</b>	
7	<b>ADD 10% CONTINGENCIES OF SUB TOTAL</b>	
8	<b>TOTAL CONSTRUCTION COST</b>	
9	<b>VALUE ADDED TAX AT 15%</b>	
10	<b>BID PRICE CARRIED FORWARD TO FORM OF OFFER AND ACCEPTANCE</b>	

HARRY GWALA DISTRICT MUNICIPALITY

UMZIMKHULU BULK SEWER

CONTRACT NUMBER: .....

CONSTRUCTION OF BULK SEWER OUTFALLS

**SCHEDULE OF QUANTITIES**

**SECTION 1.1: GENERAL**

ITEM NO	LI	PAYMENT REFERS	DESCRIPTION	UNIT	QTY	RATE	AMOUNT	
		<b>SANS 1200 A</b>	<b>SCHEUDLE 1.1: GENERAL</b>					
		<b>8.3</b>	<b>SCHEDULED FIXED-CHARGE AND VALUE-RELATED ITEMS</b>					
1.1 - 1		PSA 8.3.1	Contractual Requirements	Sum	1			
		<b>8.3.2</b>	<b>Establishment of Facilities on the Site:</b>					
		<b>PSA 8.3.2.1</b>	<b>Facilities for Employer's Agent:</b>					
1.1 - 2		PSA 8.3.2.1 (a)	(a) Furnished Offices	Sum	1			
1.1 - 3		PSA 8.3.2.1 (b)	(b) Provision of cellular phone (Sumsung Galaxy S20)	Sum	2			
1.1 - 4		PSA 8.3.2.1 (c)	(c) Provision of name boards	No	2			
1.1 - 5		PSA 8.3.2.1 (d)	(d) Provision of survey equipment	Sum	1			
1.1 - 6		PSA 8.3.2.1 (e)	(e) Provision of camera	Sum	1			
1.1 - 7		PSA 8.3.2.1 (f)	(f) Provision of i7 laptop complete with printer, modem with 4G connection	Sum	2			
		<b>8.3.2.2</b>	<b>Facilities for Contractor:</b>					
1.1 - 8		8.3.2.2 (a)	(a) Offices and storage sheds.	Sum	1			
1.1 - 9		8.3.2.2 (b)	(b) Workshops.	Sum	1			
1.1 - 10		8.3.2.2 (c)	(c) Laboratories.	Sum	1			
1.1 - 11		8.3.2.2 (e)	(e) Ablution and latrine facilities.	Sum	1			
1.1 - 12		8.3.2.2 (f)	(f) Tools and equipment.	Sum	1			
1.1 - 13		PSA 8.3.2.2 (g)	(g) Water supplies, electric power and communication.	Sum	1			
1.1 - 14		8.3.2.2 (h)	(h) Dealing with water as per clause 5.5	Sum	1			
1.1 - 15		8.3.2.2 (i)	(i) Access as per clause 5.8	Sum	1			
1.1 - 16		8.3.2.2 (j)	(j) Plant.	Sum	1			
1.1 - 17		8.3.3	Other fixed-charge obligations. (To be specified)	Sum	1			
			.....					
1.1 - 18		PSA 8.3.3.1	Issuing of notices to consumers	Sum	1			
		<b>PSA 8.3.3.2</b>	<b>OHS Act Obligations:</b>					
1.1 - 19			i) General Safety obligations (incl. provision of personal protective equipment)	Sum	1			
1.1 - 20			ii) Health and Safety plan/file including health and safety training.	Sum	1			
1.1 - 21			iii) Fulfil legislated and/or specified requirements for blasting (incl. submission of plans).	Sum	1			
1.1 - 22		PSA 8.3.5.3	Environmental Management Plan Obligations	Sum	1			
1.1 - 23		8.3.4	Remove Contractor's Site Establishment.	Sum	1			
		<b>8.4</b>	<b>SCHEDULED TIME-RELATED ITEMS</b>					
1.1 - 24		8.4.1	Contractual Requirements.	Month	18			
1.1 - 25		PSA 8.4.2	Operate and maintain facilities on the site, for duration of construction, except where otherwise stated	Month	18			
<b>SUB - TOTAL CARRIED FORWARD</b>							<b>R</b>	<b>-</b>

HARRY GWALA DISTRICT MUNICIPALITY

UMZIMKHULU BULK SEWER

CONTRACT NUMBER: .....

CONSTRUCTION OF BULK SEWER OUTFALLS

**SCHEDULE OF QUANTITIES**

**SECTION 1.1: GENERAL**

SUB - TOTAL BROUGHT FORWARD						R	-
	<b>PSA 8.4.2.1</b>	<b>Facilities for the Employer's Agent:</b>					
1.1 - 26	PSA 8.4.2.1 (a)	(a) Furnished Offices with covered carport	Month	18			
1.1 - 27	PSA 8.4.2.1 (b)	(b) Provision of cellular phone	Sum	18	R 1 000.00	18 000.00	
1.1 - 28	PSA 8.4.2.1 (c)	(c) Provision of name board	Month	18			
1.1 - 29	PSA 8.4.2.1 (d)	(d) Provision of survey equipment	Month	18			
1.1 - 30	PSA 8.4.2.1 (e)	(e) Provision of camera	Month	18			
1.1 - 31	PSA 8.4.2.1 (f)	(f) Provision of laptop complete with printer, modem with 4G connection	Sum	18	R 1 000.00	18 000.00	
	<b>8.4.2.2</b>	<b>Facilities for Contractor:</b>					
1.1 - 32	8.4.2.2 (a)	(a) Office and storage sheds.	Month	18			
1.1 - 33	8.4.2.2 (b)	(b) Workshops.	Month	18			
1.1 - 34	8.4.2.2 (c)	(c) Laboratories.	Month	18			
1.1 - 35	8.4.2.2 (e)	(e) Ablution and latrine facilities.	Month	18			
1.1 - 36	8.4.2.2 (f)	(f) Tools and equipment.	Month	18			
1.1 - 37	PSA 8.4.2.2 (g)	(g) Water supplies, electric power and communication.	Month	18			
1.1 - 38	8.4.2.2 (h)	(h) Dealing with water (Sub-clause 5.5)	Month	18			
1.1 - 39	8.4.2.2 (i)	(i) Access(Sub-clause 5.8)	Month	18			
1.1 - 40	8.4.2.2 (j)	(j) Plant.	Month	18			
1.1 - 41	8.4.3	Contractor's supervision for duration of construction.	Month	18			
1.1 - 42	8.4.4	Company and Head Office overhead costs for the duration of construction.	Month	18			
1.1 - 43	8.4.5	Other time related obligations.	Month	18			
	<b>PSA 8.4.6.1</b>	<b>OHS Act Obligations</b>					
1.1 - 44		i) General Safety obligations	Month	18			
1.1 - 45		ii) Health and Safety plan/file	Month	18			
1.1 - 46		(iii) Safety Officer	Month	18			
1.1 - 47	PSA 8.4.6.2	Security Services	Month	18			
1.1 - 48	PSA 8.4.6.4	Environmental Management Plan Compliance	Month	18			
<b>TOTAL CARRIED FORWARD TO FINAL SUMMARY</b>							

**HARRY GWALA DISTRICT MUNICIPALITY**  
**UMZIMKHULU BULK SEWER**  
**CONTRACT NUMBER: .....**  
**CONSTRUCTION OF BULK SEWER OUTFALLS**

**SCHEDULE OF QUANTITIES**

**SECTION 1.2: GENERAL**

ITEM NO	LI	PAYMENT REFERENCE	DESCRIPTION	UNIT	QTY	RATE	AMOUNT	
		<b>SANS 1200 A</b>	<b>SCHEDULE 1.2: PROVISIONAL SUMS AND DAYWORKS</b>					
		<b>PSA 8.5</b>	<b>SUMS STATED PROVISIONALLY BY THE EMPLOYERS AGENT</b>					
1.2 - 1		PSA 8.5.1 (a)	Employment of a Community Liaison Officer (CLO)	Prov Sum	18	R 6 000.00	R 108 000.00	
1.2 - 2		PSA 8.5.1 (b)	Percentage allowance on cost on item No. 1.2 - 1 for Contractor's cost and profit.	%				
1.2 - 3		PSA 8.5.2	Control tests by independent laboratory. Additional tests that may be required by the Engineer over and above normal quality control tests performed by the Contractor.	Prov Sum	1	R 30 000.00	R 30 000.00	
1.2 - 4		PSA 8.5.3 (a)	Relocation of existing services (water mains, electricity cables/poles, etc.) by Services utility	Prov Sum	1	R 200 000.00	R 200 000.00	
1.2 - 5		PSA 8.5.3 (b)	Percentage allowance on cost on item No. 1.2 - 4 for Contractor's cost and profit.	%				
1.2 - 6		PSA 8.5.4 (a)	Additional surveys and underground service detection by nominated specialist as ordered by Engineer	Prov Sum	1	R 150 000.00	R 150 000.00	
1.2 - 7		PSA 8.5.4 (b)	Percentage allowance on cost on item No. 1.2 - 6 for Contractor's cost and profit.	%				
1.2 - 8		PSA 8.5.5 (a)	Provide Training for targeted labour.	Prov Sum	1	R 150 000.00	R 150 000.00	
1.2 - 9		PSA 8.5.5 (b)	Percentage allowance on cost on item No. 1.2 - 8 for Contractor's cost and profit.	%				
1.2 - 10		PSA 8.5.6 (a)	Dewatering of foundation excavation	Days	180	R1 600.00	R 288 000.00	
1.2 - 11		PSA 8.5.6 (b)	Percentage allowance on cost on item No. 1.2 - 10 for Contractor's cost and profit.	%				
1.2 - 12		PSA 8.5.8 (a)	Safeguarding of excavations as required by the Engineer	Prov Sum	1	R100 000	R 100 000.00	
1.2 - 13		PSA 8.5.8 (b)	Overheads, charges and profit on item 1.2 - 12 above	%				
1.2 - 14		PSA 8.5.9	Compensation to affected land owners	Prov Sum	1	R550 000.00	R550 000.00	
		<b>8.7</b>	<b>DAYWORKS</b>					
1.2 - 15		(a)	Semi-skilled	hr	100			
1.2 - 16		(b)	Unskilled	hr	100			
1.2 - 17		(c)	Construction Hand and Operator	hr	50			
1.2 - 18		(d)	Carpenter	hr	50			
1.2 - 19		(e)	Clerk	hr	50			
1.2 - 20		(f)	Artisans	hr	50			
1.2 - 21		(g)	Foreman	hr	50			
1.2 - 22		(h)	Gangers and Section Leaders	hr	50			
1.2 - 23		(i)	Steel fixer	hr	50			
1.2 - 24		(j)	Bricklayer or Plasterer	hr	50			
1.2 - 25		(k)	Welder	hr	50			
<b>SUB - TOTAL BROUGHT FORWARD TO NEXT PAGE</b>								

**HARRY GWALA DISTRICT MUNICIPALITY**  
**UMZIMKHULU BULK SEWER**  
**CONTRACT NUMBER: .....**  
**CONSTRUCTION OF BULK SEWER OUTFALLS**

**SCHEDULE OF QUANTITIES**  
**SECTION 1.2: GENERAL**

SUB - TOTAL BROUGHT FORWARD FROM PREVIOUS PAGE					
		<b>PLANTHIRE (WORK RATES ON SITE)</b>			
1.2 - 26		a) Excavator 20 ton	hr	50	
1.2 - 27		b) Loader 12 ton	hr	50	
1.2 - 28		c) Tipper truck 10 m <sup>3</sup>	hr	50	
1.2 - 29		d) Water tanker	hr	50	
1.2 - 30		e) TLB	hr	5	
1.2 - 31		f) Rollers	hr	50	
1.2 - 32		g) Generator	hr	500	
		<b>TRANSPORT COST (TO AND FROM SITE)</b>			
		<u>Note:</u>			
		Distance shall be measured one way only (tender rates shall include for transport in both directions to and from site)			
		<u>Low bed</u>			
1.2 - 33		a) Low-bed (suitable for the largest piece of equipment above)	km	100	
		<u>Tipper truck</u>			
1.2 - 34		(a) Small	km	100	
1.2 - 35		(b) Medium	km	100	
		<u>Flatbed truck</u>			
1.2 - 36		(a) Small	km	100	
1.2 - 37		(b) Medium	km	100	
		<u>Water tanker</u>			
1.2 - 38		(a) Small	km	100	
1.2 - 39		(b) Medium	km	100	
1.2 - 40		(c) Large	km	100	
		<b>MATERIALS FOR DAYWORKS</b>			
1.2 - 41		(a) Materials used in the execution of dayworks	PC item	1	
1.2 - 42		(b) Overheads, charges and profit on above	%		
	<b>8.8</b>	<b>TEMPORARY WORKS</b>			
1.2 - 43	8.8.1	Main Access Road to Works (construct and maintain)	Sum	1	
1.2 - 44	8.8.2	Dealing with traffic (or accomodation of traffic) during construction	Sum	1	
1.2 - 45	PSA 8.8.4 (c)	Excavate and backfill by hand in soft material to expose existing services - only on approval of Employer's Agent.	m <sup>3</sup>	50	
1.2 - 46	PSA 8.8.4 (d)	Temporary Protection of existing services	Sum	1	
1.2 - 47	8.8.5	Detail setting out of the Works from survey beacons by a registered surveyor and all other survey related work.	Sum	1	
1.2 - 48	PSA 8.8.7	Provision of records/as-built drawings	Sum	1	
<b>TOTAL CARRIED FORWARD TO FINAL SUMMARY</b>					

HARRY GWALA DISTRICT MUNICIPALITY  
 UMZIMKHULU BULK SEWER  
 CONTRACT NUMBER: .....  
 CONSTRUCTION OF BULK SEWER OUTFALLS

**SCHEDULE OF QUANTITIES**  
**SECTION 2: PIPELINES**

ITEM NO	LI	PAYMENT REFERENCE	DESCRIPTION	UNIT	QTY	RATE	AMOUNT
		<b>SANS 1200 C</b>	<b>SCHEDULE 2.1: SITE CLEARANCE</b>				
		<b>8.2</b>	<b>SCHEDULED ITEMS</b>				
2.1 - 1		8.2.1	Clear and grub (site servitude 12 m width)	m	4 620		
2.1 - 2		8.2.2	Remove and grub large trees and tree stumps of girth:				
2.1 - 3			a) over 1 m and up to and including 2 m	No	5		
2.1 - 4			b) over 2 m and up to and including 3 m	No	5		
2.1 - 5			c) over 3 m and up to and including 4 m	No	5		
2.1 - 5		8.2.5	Take down existing fences	m	300		
2.1 - 6		PSC 8.2.11	Reinstate fences to original condition on completion of the scheduled work	m	300		
<b>SUB - TOTAL CARRIED FORWARD TO FINAL SUMMARY</b>							

HARRY GWALA DISTRICT MUNICIPALITY

UMZIMKHULU BULK SEWER

CONTRACT NUMBER: .....

CONSTRUCTION OF BULK SEWER OUTFALLS

SCHEDULE OF QUANTITIES

SECTION 2: PIPELINES

ITEM NO	LI	PAYMENT REFERENCE	DESCRIPTION	UNIT	QTY	RATE	AMOUNT
		<b>SANS 1200 DB</b>	<b><u>SCHEDULE 2.2: EARTHWORKS (PIPE TRENCHES)</u></b>				
		<b>8.3</b>	<b>SCHEDULED ITEMS</b>				
		8.3.2	Excavation				
2.2 - 1			a) (i) Excavation in all materials for trenches	m <sup>3</sup>	12725		
2.2 - 2			(ii) Backfill and compaction to trenches to 90% Mod AASHTO density	m <sup>3</sup>	3 818		
			b) Extra over item 8.3.2 above for:				
2.2 - 3			2) Hard rock excavation	m <sup>3</sup>	2545		
2.2 - 4			c) Excavate and dispose of unsuitable material from trench bottom	m <sup>3</sup>	1909		
		8.3.3	Excavation Ancillaries				
		8.3.3.1	Make up deficiency in backfill material				
2.2 - 5			c) by importation from commercial or off-site sources selected by the Contractor	m <sup>3</sup>	453		
		8.3.3.4	Overhaul within 30 km radius				
2.2 - 6			a) Limited overhaul	m <sup>3</sup>	191		
2.2 - 7			b) Long overhaul, more than 30 km radius	m <sup>3</sup> .km	636		
		8.3.4	Particular Items				
2.2 - 8			a) Shore trench opposite structure or service	m	900		
2.2 - 9		PSDB 8.3.4.1	Remove and store block or brick paving at the site office until working area is ready for reinstatement	m <sup>2</sup>	60		
		8.3.5	Existing services that intersect or adjoin a pipe trench				
2.2 - 10			a) Services that intersect a trench	No	150		
2.2 - 11			b) Services that adjoin a trench	m	500		
		8.3.6	Finishing				
2.2 - 12		PSDB 8.3.6.1	Reinstate paving with stored paving blocks	m <sup>2</sup>	300		
<b>SUB - TOTAL CARRIED FORWARD TO FINAL SUMMARY</b>							



HARRY GWALA DISTRICT MUNICIPALITY  
 UMZIMKHULU BULK SEWER  
 CONTRACT NUMBER: .....  
 CONSTRUCTION OF BULK SEWER OUTFALLS

**SCHEDULE OF QUANTITIES**

**SECTION 2: PIPELINES**

ITEM NO	LI	PAYMENT REFERENCE	DESCRIPTION	UNIT	QTY	RATE	AMOUNT
		<b>SANS 1200 LB</b>	<b><u>SCHEDULE 2.3: BEDDING (PIPES)</u></b>				
		<b>8.2</b>	<b>SCHEDULED ITEMS</b>				
		<b>8.2.1</b>	<b>PROVISION OF BEDDING FROM TRENCH EXCAVATION</b>				
2.3 - 1			a) Selected Granular material	m³	4 222		
2.3 - 2			(b) Selected fill material	m³	1 392		
		<b>8.2.2</b>	<b>SUPPLY ONLY BEDDING BY IMPORTATION</b>				
		<b>8.2.2.3</b>	<u>From other necessary excavations (provisional)</u>				
2.3 - 3			(a) Selected granular material	m³	422		
2.3 - 4			(b) Selected fill material	m³	139		
		<b>8.2.2.3</b>	<u>Bedding from commercial sources (provisional)</u>				
2.3 - 5			(a) Selected granular material	m³	2 955		
2.3 - 6			(b) Selected fill material	m³	974		
<b>SUB - TOTAL CARRIED FORWARD TO FINAL SUMMARY</b>							

HARRY GWALA DISTRICT MUNICIPALITY  
 UMZIMKHULU BULK SEWER  
 CONTRACT NUMBER: .....  
 CONSTRUCTION OF BULK SEWER OUTFALLS

**SCHEDULE OF QUANTITIES**  
**SECTION 2: PIPELINES**

ITEM NO	LI	PAYMENT REFERENCE	DESCRIPTION	UNIT	QTY	RATE	AMOUNT
		<b>SANS</b>	<b><u>SCHEDULE 2.4: SEWERS</u></b>				
		1200 L					
		<b>8.2</b>	<b>SCHEDULED ITEMS</b>				
		8.2.1	Supply,Lay, Joint, Bed (Class___), and Test pipeline (a) Supply, lay,bed, joint and install PVC sewer pipes (SANS966-1), test and disinfect for the following diameters.				
2.4 - 1			i) Pipeline No.1 (0.315m dia) ( Class 51)	m	1 180		
2.4 - 2			ii) Pipeline No.2 (0.315m dia) ( Class 51)	m	400		
2.4 - 3			iii) Pipeline No.3 (0.355m dia) ( Class 51)	m	550		
2.4 - 4			iv) Pipeline No.4 (0.450m dia) ( Class 51)	m	250		
2.4 - 5			v) Pipeline No.5 (0.315m dia) ( Class 51)	m	700		
2.4 - 6			vi) Pipeline No.6 (0.450m dia) ( Class 51)	m	1 000		
2.4 - 7			vii) Pipeline No.7 (0.500m dia) ( Class 51)	m	120		
<b>SUB - TOTAL CARRIED FORWARD TO FINAL SUMMARY</b>							

HARRY GWALA DISTRICT MUNICIPALITY  
 UMZIMKHULU BULK SEWER  
 CONTRACT NUMBER: .....  
 CONSTRUCTION OF BULK SEWER OUTFALLS

**SCHEDULE OF QUANTITIES**  
**SECTION 2: PIPELINES**

ITEM NO	LI	PAYMENT REFERENCE	DESCRIPTION	UNIT	QTY	RATE	AMOUNT
		<b>SANS 1200 LG</b>	<b><u>SCHEDULE 2.5: PIPE JACKING</u></b>				
		<b>8.2</b>	<b>SCHEDULED ITEMS</b>				
		8.2.1	Jacking Establishment				
2.5 - 1			a) Fixed charges	Sum	1		
2.5 - 2			b) Time-related charges	Month	12		
		8.2.2	Supply of pipes to be jacked				
2.5 - 3			c) 675 mm dia concrete pipe with 13 mm sacrificial layer, Class 100 D	m	200		
		8.2.3	Jacking of pipes				
			With diameters of:				
2.5 - 4			a) 315 mm	m	50		
2.5 - 5			b) 355 mm	m	50		
2.5 - 6			c) 450 mm	m	50		
2.5 - 7			d) 500 mm	m	50		
		8.2.4	Excavation for Jacking	m <sup>3</sup>	151		
2.5 - 6							
2.5 - 7		PSA8.2.5	Extra-over for 8.2.1 and 8.2.4 for unforeseen rock and boulders (Provisional)	m <sup>3</sup>	90		
<b>SUB - TOTAL CARRIED FORWARD TO FINAL SUMMARY</b>							

HARRY GWALA DISTRICT MUNICIPALITY  
 UMZIMKHULU BULK SEWER  
 CONTRACT NUMBER: .....  
 CONSTRUCTION OF BULK SEWER OUTFALLS

**SCHEDULE OF QUANTITIES**  
**SECTION 3: PUMPSTATION MANHOLES AND JUNCTION BOXES**

ITEM NO	LI	PAYMENT REFERENCE	DESCRIPTION	UNIT	QTY	RATE	AMOUNT
		<b>SANS 1200 D</b>	<b><u>SCHEDULE 3.1: EARTHWORKS</u></b>				
		<b>8.3</b>	<b>SCHEDULED ITEMS</b>				
			<b>Junction Boxes and Manholes</b>				
		<b>8.3.2</b>	<b>Bulk Excavation</b>				
3.1 - 1			a) (i) Excavation in all materials for trenches	m <sup>3</sup>	1 414		
3.1 - 2			(ii) Backfill and compaction to trenches to 90% Mod AASHTO density	m <sup>3</sup>	283		
			b) Extra-over for				
3.1 - 3			2) hard rock excavation	m <sup>3</sup>	424		
		<b>8.3.4</b>	<b>Importing of materials</b>				
3.1 - 4			a) Extra-over for importation of materials from commercial sources or from borrow pits	m <sup>3</sup>	424		
		<b>8.3.6</b>	<b>Overhaul within 30 km radius</b>				
3.1 - 5			a) Limited overhaul	m <sup>3</sup>	99		
3.1 - 6			b) Long overhaul, more than 30 km radius	m <sup>3</sup> .km	990		
<b>SUB - TOTAL CARRIED FORWARD TO FINAL SUMMARY</b>							

HARRY GWALA DISTRICT MUNICIPALITY

UMZIMKHULU BULK SEWER

CONTRACT NUMBER: .....

CONSTRUCTION OF BULK SEWER OUTFALLS

**SCHEDULE OF QUANTITIES**

**SECTION 3: MANHOLES AND JUNCTION BOXES**

ITEM NO	LI	PAYMENT REFERENCE	DESCRIPTION	UNIT	QTY	RATE	AMOUNT
		<b>SANS 1200 GA</b>	<b>SCHEDULE 3.2: CONCRETE (SMALL WORKS)</b>				
		<b>8.2</b>	<b>SCHEDULED FORMWORK ITEMS</b>				
3.2 - 1		8.2.1	Rough	m <sup>2</sup>	77		
3.2 - 2		8.2.2	Smooth	m <sup>2</sup>	44		
		8.2.4	Box Out Holes/Form Voids b) Large, other than circular, of area over 0.1m <sup>2</sup> up to and including 0.5m <sup>2</sup>  Over and up to and including 1) 1m - 1.5m deep	No	15		
3.2 - 3			c) Large, circular, of diameter over 0,35m and up to and including 0,7m  Over and up to and including 1) 1m - 1.5m deep	No	24		
3.2 - 4				No	24		
		<b>8.3</b>	<b>SCHEDULED REINFORCEMENT ITEMS</b>				
		8.3.1	Steel Bars				
3.2 - 5			a) Mild-tensile steel bars in the following: (i) R10	t	1		
3.2 - 6			b)High-tensile steel bars in the following: (i) Y16	t	0		
3.2 - 7			(ii)Y20	t	1		
3.2 - 8		8.3.2	High-Tensile Welded Mesh: Reinforcing Mesh 617	m <sup>2</sup>	110		
3.2 - 9		<b>8.4</b>	<b>SCHEDULED CONCRETE ITEMS</b>				
3.2 - 10		8.4.2	Blinding layer in 50mm concrete, Grade 15MPa	m <sup>2</sup>	110		
		8.4.3	Strength concrete, Grade 25MPa	m <sup>3</sup>	18		
3.2 - 11		8.4.4	Unformed surface finishes a) Steel-floated finish	m <sup>2</sup>	60		
3.2 - 12			b) Wood-floated finish	m <sup>2</sup>	60		
		<b>8.5</b>	<b>JOINTS</b>				
3.2 - 13			Polyurethane joint sealer 10mm thick openings between precast slabs to be filled with an approved polyurethane sealer	m	120		
3.2 - 14			Bitumen filler Seal around pipe with bituminous roofing felt type 4D and bitumen filler	m	120		
		<b>8.6</b>	<b>MANUFACTURE (OR SUPPLY) AND ERECT PRECAST ELEMENTS</b>				
			Precast concrete units supplied and fixed complete including all Strength concrete 35MPa/19mm a) Supply, delivery and installation of precast concrete pipe markers	No.	60		
		<b>8.8</b>	<b>HD BOLTS AND MISCELLANEOUS METAL WORK</b>				
			a) Step irons as per drawing	No	150		
<b>SUB - TOTAL BROUGHT FORWARD TO NEXT PAGE</b>							

HARRY GWALA DISTRICT MUNICIPALITY  
 UMZIMKHULU BULK SEWER  
 CONTRACT NUMBER: .....  
 CONSTRUCTION OF BULK SEWER OUTFALLS

**SCHEDULE OF QUANTITIES**  
**SECTION 3: MANHOLES AND JUNCTION BOXES**

ITEM NO	LI	PAYMENT REFERENCE	DESCRIPTION	UNIT	QTY	RATE	AMOUNT
		<b>SANS 1200 GE</b>	<b><u>SCHEDULE 3.3: PRECAST CONCRETE (STRUCTURAL)</u></b>				
		<b>8.2</b>	<b>SCHEDULED ITEMS</b>				
		<b>8.2.1</b>	<b><u>Provide Structural Precast Units:</u></b>				
3.3 - 1			a) 500mmØ x 500mm manhole rings	No	50		
3.3 - 2			b) 1000mmØx 500mm manhole rings	No	350		
3.3 - 3			c) 1000mmØ starter rings 250mm high	No	80		
3.3 - 4			d) 1000mm OD precast slab	No	80		
3.3 - 5			e) 750mm with 560mm hole reducer	No	40		
3.3 - 6			f) 750mm ID x 500 shaft sections	No	200		
3.3 - 7			g) 750mm OD cover slab	No	40		
3.3 - 8			h) 150mm Thick brick manhole concrete cover slabs	No	50		
3.3 - 9			i) 600mmØ Rocla lid PA-8243 concrete cover	No	50		
3.3 - 10			j) 560mmØ Concrete manhole lid	No	50		
		<b>8.2.2</b>	<b><u>Erection of Structural Precast Units</u></b>				
3.3 - 11			a) 500mmØ x 500mm manhole rings	No	50		
3.3 - 12			b) 1000mmØx 500mm manhole rings	No	350		
3.3 - 13			c) 1000mmØ starter rings 250mm high	No	80		
3.3 - 14			d) 860mm OD precast slab	No	80		
3.3 - 15			e) 750mm with 560mm hole reducer	No	40		
3.3 - 16			f) 750mm ID shaft sections	No	200		
3.3 - 17			g) 750mm OD cover slab	No	40		
3.3 - 18			h) 150mm Thick brick manhole concrete cover slabs	No	50		
3.3 - 19			i) 600mmØ Rocla lid PA-8243 concrete cover	No	50		
3.3 - 20			j) 560mmØ Concrete manhole lid	No	50		
<b>SUB - TOTAL CARRIED FORWARD TO FINAL SUMMARY</b>							

HARRY GWALA DISTRICT MUNICIPALITY  
 UMZIMKHULU BULK SEWER  
 CONTRACT NUMBER: .....  
 CONSTRUCTION OF BULK SEWER OUTFALLS

**SCHEDULE OF QUANTITIES**  
**SECTION 3: PUMPTATMANHOLES AND JUNCTION BOXES**

ITEM NO	LI	PAYMENT REFERENCE	DESCRIPTION	UNIT	QTY	RATE	AMOUNT
		PB	<b><u>SCHEDULE 3.4: MASONRY WORKS</u></b>				
3.4 - 1			(a) 230 mm brick walls of burnt clay, face brick, in class II mortar, laid in stretcher bond.	m <sup>2</sup>	250		
3.4 - 2			(c) R8 mild steel reinforcement cut to lengths and built into brick lintels	t	2.0		
3.4 - 3			(d) Brick reinforcement 210 mm wide built into brick walls with sufficient laps at end joints, angles and intersections (measured net)	m	250		
			<b><u>Movement joints</u></b>				
3.4 - 4			a) Movement joint formed of 20 mm soft board built in vertically between brick skins	m <sup>2</sup>	600		
3.4 - 5			b) Cut face brick-on-end soldier course external window cill 180 mm wide, set sloping and slightly projecting in cement mortar and pointed on top and front edge and projecting soffit including all necessary fair raking cutting to facings under and fair and fitted ends.	m	1 000		
			<b><u>WATERPROOFING</u></b>				
3.4 - 6			a) Waterproofing to walls i) 377 micron embossed black polyethylene damp-proof course to walls, cills, etc. (measured net)	m	300		
3.4 - 7			Prepare and apply two coats "Brixeal" or similar approved bitumen emulsion waterproof compound on walls	m <sup>2</sup>	75		
<b>SUB - TOTAL CARRIED FORWARD TO FINAL SUMMARY</b>							

**HARRY GWALA DISTRICT MUNICIPALITY**

UMZIMKHULU BULK SEWER

CONTRACT NUMBER: .....

CONSTRUCTION OF BULK SEWER OUTFALLS

**SCHEDULE OF QUANTITIES**

**SECTION 4: ACCESS ROADS**

ITEM NO	LI	PAYMENT REFERENCE	DESCRIPTION	UNIT	QTY	RATE	AMOUNT
		<b>SANS 1200</b>	<b>SCHEDULE 4.1: Access Roads</b>				
			<b>TREATMENT OF ROAD-BED</b>				
4.1 - 01			Road-bed preparation and compaction of material	m <sup>2</sup>	650		
4.1 - 02			Rip and Compact to 93 % mod. AASHTO maximum density	m <sup>3</sup>	650		
			<b>EARTHWORKS</b>				
			Cut to Fill				
			Compact to 90 % mod. AASHTO maximum density				
4.1 - 03			i) for platforms	m <sup>3</sup>	1000		
4.1 - 04			ii) for roads	m <sup>3</sup>	500		
			<b>SURFACE FINISHES</b>				
4.1 - 05			Topsoiling	m <sup>2</sup>	700		
4.1 - 06			Grassing	m <sup>2</sup>	700		
			<b>BASE</b>				
			Construct gravel base with material from borrow pits in all materials materials				
4.1 - 07			150mm to roads compacted to 95% Mod. AASHTO maximum density	m <sup>3</sup>	400		
			Process Material by means of:				
4.1 - 08			Stabilizing	m <sup>3</sup>	360		
4.1 - 09			Portland cement	t	22		
			<b>PROVIDE EDGE RESTRAINTS AS SHOWN ON DRAWINGS FOR</b>				
			Barrier Kerb. Fig.3 non standard kerb stone	m	200		
			Edge beam class 25/19 ( 250x150)	m	200		
			<b>CONSTRUCT PRECAST CONCRETE SEGMENTED PAVING</b>				
			Paving complete on as shown on Drawing, in a herring bond pattern to approval				
4.1 - 010			a) on Area 1, Type S-A units	m <sup>2</sup>	1500		
4.1 - 011			Cutting units to fit edge restraint	m	450		
<b>SUB - TOTAL CARRIED FORWARD TO FINAL SUMMARY</b>							



HARRY GWALA DISTRICT MUNICIPALITY  
 UMZIMKHULU BULK SEWER  
 CONTRACT NUMBER: .....  
 CONSTRUCTION OF BULK SEWER OUTFALLS

**SCHEDULE OF QUANTITIES**

**SUMMARY OF BILL OF QUANTITIES**

SECTION	DESCRIPTION	AMOUNT
1.1	<b>Schedule 1.1: General</b> .....	
1.2	<b>Schedule 1.2: Provisional Sum and Dayworks</b> .....	
2	<b>Pipelines</b> .....	
2.1	Schedule 2.1 - Site Clearance.....	
2.2	Schedule 2.2 - Earthworks (Pipe Trenches).....	
2.3	Schedule 2.3 - Bedding (Pipes).....	
2.4	Schedule 2.4 - Sewers.....	
2.5	Schedule 2.5 - Pipe Jacking.....	
3	<b>Pumpstation, Manholes and Junction Boxes</b> .....	
3.1	Schedule 3.1 - Earthworks.....	
3.2	Schedule 3.2 - Concrete (Small works).....	
3.3	Schedule 3.3 - Precast Concrete (Structural).....	
3.4	Schedule 3.4 - Masonry works.....	
4	<b>Access Roads</b> .....	
4.1	Schedule 4.1 -Access Roads.....	
6	<b>SUB TOTAL</b>	
7	<b>ADD 10% CONTINGENCIES OF SUB TOTAL</b>	
8	<b>TOTAL CONSTRUCTION COST</b>	
9	<b>VALUE ADDED TAX AT 15%</b>	
10	<b>BID PRICE CARRIED FORWARD TO FORM OF OFFER AND ACCEPTANCE</b>	

HARRY GWALA DISTRICT MUNICIPALITY

CONSTRUCTION OF UMZIMKHULU BULK SEWER OUTFALL

HGDM 759/HGDM/2022

---

## C2.2 Schedule of Quantities

**UMZIMKHULU BULK SEWER**  
**CONTRACT No. 759/HGDM/2022**  
**CONSTRUCTION OF UMZIMKHULU BULK SEWER OUTFALL**

**PART C3: SCOPE OF WORK**

**INDEX**

<b>INDEX</b>	<b>Page SW</b>
<b>PART 1: CIVIL SCOPE OF WORKS</b>	<b>3</b>
C3.1 STANDARDISED SPECIFICATIONS	3
C3.2 PROJECT SPECIFICATIONS	4
<b>PROJECT SPECIFICATION: PORTION 1</b>	<b>6</b>
PS-1 PROJECT DESCRIPTION	6
PS-2 EXTENT OF THE WORKS	7
PS-3 DESCRIPTION OF THE SITE AND ACCESS	7
PS-4 NATURE OF GROUND AND SUBSOIL INVESTIGATIONS	7
PS-5 ENGINEERING AND DESIGN	7
PS-6 CONSTRUCTION AND MANAGEMENT REQUIREMENTS	9
PS-7 CONSTRUCTION PROGRAMME	11
PS-8 SITE FACILITIES AVAILABLE	12
PS-9 SITE FACILITIES REQUIRED	12
PS 10. EXISTING SERVICES	15
PS-11 REQUIREMENTS FOR ACCOMMODATION OF TRAFFIC	18
PS-12 OCCUPATIONAL HEALTH AND SAFETY (Read with SANS 1921 - 1: 2004 clause 4.14)	18
PS-13 ADVERSE WEATHER CONDITIONS	20
PS-14 SITE MEETINGS AND REPORTING	21
PS-15 PREFERENTIAL PROCUREMENT	21
PS-16 EPWP SPECIFICATION	21
PS 17 SUBCONTRACTING OF A PROTION OF THE CONTRACT	25
<b>PROJECT SPECIFICATION: PORTION 2</b>	<b>26</b>

**HARRY GWALA DISTRICT MUNICIPALITY**  
**CONSTRUCTION OF UMZIMKHULU BULK SEWER OUTFALL**  
**HGDM 759/HGDM/2022**

---

SABS 1200 PSA: GENERAL	27
PARTICULAR SPECIFICATION: PA	73
PARTICULAR SPECIFICATION: PB	
PARTICULAR SPECIFICATION PC	76

## PART 1: CIVIL SCOPE OF WORKS

### C3.1 STANDARDISED SPECIFICATIONS

The standard specifications on which this contract is based are Standards South Africa's Standardized Specifications for Civil Engineering Construction SABS 1200.

Although not bound in nor issued with this Document, the following Sections of the Standardized Specifications of SABS 1200 shall form part of this Contract:

A	1986	:	GENERAL				
AA	1986		GENERAL - SMALL WORKS				
AB	1986	:	ENGINEER'S OFFICE				
C	1980	:	SITE CLEARANCE (As amended 1982)				
D	1988		EARTHWORKS				
DA	1988	:	EARTHWORKS (Small Works)				
DB	1989	:	EARTHWORKS (Pipe trenches)				
G	1982		CONCRETE - STRUCTURAL				
GA	1982	:	CONCRETE (SMALL WORKS)				
GE	1984		PRECAST CONCRETE - STRUCTURAL				
HA	1990	:	STRUCTURAL STEELWORKS				
LB	1990	:	BEDDING - PIPES				
L	1983		MEDIUM PRESSURE PIPELINES				
LC	1981		CABLE DUCTS				
H	1985		STRUCTURAL STEELWORK				
HC	1988	:	CORROSION PROTECTION FOR STRUCTURAL STEELWORKS				

The following SANS specifications are also referred to in this document and the Contractor is advised to obtain them from Standards South Africa (a division of SABS) in Pretoria.

SANS 1921 (2004): Construction and Management Requirements for Works Contracts

- Part 1: General Engineering and Construction Works; and
- Part 2: Accommodation of Traffic on Public Roads Occupied by the Contractor.

**C3.2 PROJECT SPECIFICATIONS**

The project specification is covered in the following sections:

<b>ITEM</b>	<b>DESCRIPTION</b>
	STATUS
	PROJECT SPECIFICATION PORTION 1: GENERAL
PS-1	Project Description
PS-2	Extent of the Works
PS-3	Description of the Site and Access
PS-4	Nature of Ground and Subsoil Conditions
PS-5	Construction and Management Requirements
PS-6	Construction Programme
PS-7	Site Facilities Available
PS-8	Site Facilities Required
PS-9	Existing Services
PS-10	Requirements for Accommodation of Traffic
PS-11	Occupational Health and Safety
PS-12	Adverse Weather Conditions
PS-13	Site Meetings & Reporting
PS-14	Preferential Procurement
	PROJECT SPECIFICATION PORTION 2
PSA	General
PSD	Earthworks
PSDB	Earthworks (Pipe Trenches)
PSG/PSGA	Concrete (Small Works)
PSLB	Bedding (Pipes)
PSG	Concrete (Structural)
PSLE	Stormwater Drainage
	PARTICULAR SPECIFICATIONS
PA	Brickwork and Plaster
PB	Carpentry, Joinery, and Ironmongery
PC	Painting
PF	Valves
PES	Environmental Specification
PE	Project Specification Occupational Health & Safety Specification

## **STATUS**

The Project Specification, consisting of two parts, forms an integral part of the contract and supplements the Standard Specifications.

Part A contains a general description of the works, the site and the requirements to be met.

Part B contains variations, amendments and additions to the Standardized Specifications and, if applicable, the Particular Specifications.

In the event of any discrepancy between a part or parts of the Standardized or Particular Specifications and the Project Specification, the Project Specification shall take precedence. In the event of a discrepancy between the Specifications, (including the Project Specifications) and the drawings and / or the Bill of Quantities, the discrepancy shall be resolved by the Engineer before the execution of the work under the relevant item.

**PROJECT SPECIFICATION: PORTION 1**

**SABS 1200 PS: GENERAL**

**PS-1 PROJECT DESCRIPTION**

**PS-1.1 Employer's Objective**

The Harry Gwala District Municipality is responsible for addressing any sewer infrastructure challenges that the communities falling under its entire area of jurisdiction may face. The Harry Gwala District Municipality, in its capacity as WSA now intends to address the sewer infrastructure challenges that exist in the uMzimkhulu Town which falls under the uMzimkhulu Local Municipality.

**PS-1.2 Overview of the Works**

Planning and design of uMzimkhulu bulk sewer is meant to address the sewer infrastructure challenges in uMzimkhulu Town under the uMzimkhulu Local Municipality. The scope of works includes the construction of the uMzimkhulu bulk sewer.

**Under this Contract, Harry Gwala District Municipality intends to implement the,**

**CONSTRUCTION OF UMZIMKHULU BULK SEWER OUTFALL**



**PS-2 EXTENT OF THE WORKS**

Under this contract, the successful contractor will be required to construct the outfall sewer as per the following specifications:

<b>CONSTRUCTION OF UMZIMKHULU BULK SEWER OUTFALL</b>	<b>Units</b>	<b>Quantity</b>
<b>Construction of Sewer Outfall</b>		
Supply, lay and bed (flexible pipe bedding) uPVC pipes complete with compression fittings, coupling, test and disinfect for the following diameters.		
Gravity pipeline - 315mm diameter Class 51	m	1830
Gravity pipeline - 355 mm diameter Class 51	m	550
Gravity pipeline - 450 mm diameter Class 51	m	1000
Gravity pipeline - 500 mm diameter Class 51	m	120
<b>Construction of Manholes</b>		
Supply, delivery and installation of precast manholes with the following diameters.		
750mm NB	No.	100
1000mm NB	No.	100
<b>Construction of Junction Boxes</b>		
Supply, delivery and construction of Junction Boxes as per drawings.		
Formwork items,		
Narrow widths (up to 300 mm wide)	m	1000
Box out holes/form voids, Small, other than circular, of area up to and including 0.1 m <sup>2</sup>		
Over 0m up to 0.5m deep	No.	100
Reinforcement	t	30
Concrete Grade 25MPa	m <sup>3</sup>	300
Blinding layer (15/19) in 50mm concrete (Chamber floors)	m <sup>2</sup>	200

**PS-3 DESCRIPTION OF THE SITE AND ACCESS**

**PS-3.1 Access**

Planning and design of uMzimkhulu Bulk Sewer falls within uMzimkhulu Local Municipality. uMzimkhulu LM is one of four local municipalities that constitute Harry Gwala District Municipality. It borders onto the Dr Nkosazana Dlamini Zuma, Greater Kokstad, Ubuhlebezwe, Umzumbe and uMuziwabantu Local Municipalities. It covers an area of approximately 2 436 km<sup>2</sup>.

The uMzimkhulu Bulk Sewer Outfall is to be constructed in uMzimukhulu town which is located at GPS coordinates 30°15'36.97"S and 29°56'28.76"E. The town can be accessed through R56 from Pietermaritzburg town and R56-N2-R56 from Kokstad town.

**PS-4 NATURE OF GROUND AND SUBSOIL INVESTIGATIONS**

A detailed geotechnical investigation was conducted on the project. A detailed Geotech report will be provided to bidders upon request.

**PS-5 ENGINEERING AND DESIGN**

**PS-5.1 Design Services and Activity Matrix**

The following matrix of responsibilities for design of permanent and temporary works will apply:

Activity Work designed by, per design stage	Responsible Party
Concept, feasibility and overall process	Employer
Basic engineering and detail layouts to tender stage	Employer
Final design approved for construction stage	Employer
Temporary works	Contractor
Permanent Works	Contractor
Preparation of as built drawings	Contractor

#### PS-5.2 Employer's Design

The Employer's design will be for all permanent works and will be detailed in drawings, site instructions the technical specifications to be issued with the tender documents and issued during construction.

#### PS-5.3 Design Brief

The contractor will be responsible for design of the following (which are all subject to approval by the Engineer):

- Site layouts for the contractor's camp and office accommodation
- Site layouts for the Engineer Representative's temporary office accommodation
- Construction Methodology
- Formwork
- All other temporary works
- Concrete Mix designs

The costs of the designs will be deemed to have been included in the scheduled items in the Schedule of Quantities. No other additional payments will be certified to cover these activities.

#### PS-5.4 Drawings

The following drawings will be required to be prepared by the contractor as a minimum:

- Site layouts for the contractor's camp and office accommodation
- Site layouts for the Engineer Representative's temporary office accommodation

The costs of the designs will be deemed to have been included in the scheduled items in the Schedule of Quantities. No other additional payments will be certified to cover these activities.

The tender drawings are applicable to the contractor are detailed in Part C5 of these documents. These drawings have been used for setting up the Bills of Quantities.

#### PS-5.5 Design Procedures

The contractor will be required to furnish the following designs for approval by the Engineer at the indicated times:

Site layouts of the Contractor's camp and office accommodation – within 14 days from commencement date of the contract and in any case prior to the erection of the contractor's camp and offices

Layouts for the Engineer's representative office – within 14 days from commencement date of the contract and in any case prior to the erection of the Engineer's Representative's temporary office premises.

Formwork design – within 14 days of commencement of work and in any case prior to the construction of permanent reinforced concrete works.

Scaffolding and all staging work – within 14 days of commencement of work and in any case prior to the construction of permanent reinforced concrete works.

Concrete Mix Designs for all classes of concrete as measured in the Schedule of Quantities prior to the placement of any concrete work

The costs of the designs will be deemed to have been included in the scheduled items in the Schedule of Quantities. No other additional payments will be certified to cover these activities.

**PS-5.6 Interface with other Contractors**

The contractor may be required to provide access to other contractors undertaking work as per parallel contracts. The costs of this interface will be deemed to have been allowed for in the appropriate items in the Schedule of Quantities. No other additional payments will be certified to cover these activities.

**PS-6 CONSTRUCTION AND MANAGEMENT REQUIREMENTS**

**PS-6.1 General**

The Contractor is referred to SANS 1921: 2004: Construction and Management Requirements for Works Contracts, Part 1: General Engineering and Construction Works, and Part 2: Accommodation of Traffic on Public Roads. These specifications shall be applicable to the contract under consideration and the Contractor shall comply with all requirements relevant to the project.

Certain aspects however require further attention as described hereafter.

**PS-6.2 Quality Assurance (QA) *(Read with SANS 1921 – 1: 2004 clause 4.4)***

The Contractor will be solely responsible for the production of work that complies with the Specifications to the satisfaction of the Engineer. To this end it will be the full responsibility of the Contractor to institute an appropriate Quality Assurance (QA) system on site. The Engineer will audit the Contractor's quality assurance (QA) system on a regular basis to verify that adequate independent checks and tests are being carried out and to ensure that the Contractor's own control is sufficient to identify any possible quality problems which could cause a delay or failure.

The Contractor shall ensure that efficient supervisory staff, the required transport, instruments, equipment and tools are available to control the quality of his own workmanship in accordance with his QA-system. His attention is drawn to the fact that it is not the duty of the Engineer or the Engineer's representative to act as foreman or surveyor.

**PS-6.3 Management and disposal of water *(Read with SANS 1921-1: 2004 clause 4.6)***

The Contractor shall pay special attention to the management and disposal of water and stormwater on the site. It is essential that all completed works or parts thereof are kept dry and properly drained.

Claims for delay and for repair of damage caused to the works as a result of the Contractor's failure to properly manage rain and surface water, will not be considered.

**PS-6.4 Disposal of spoil or surplus material** (Read with SANS 192-1: 2004 clause 4.10)

The Contractor shall dispose all surplus and unsuitable material in legal spoil areas of his own choice. He shall be responsible for all arrangements necessary to obtain such spoil sites.

**PS-6.5 Testing** (Read with SANS 1921 – 1 : 2004 clause 4.11)

PS-6.5.1 Process control

The Contractor shall arrange for all tests required for process control to be done by a laboratory acceptable to and approved by the Engineer.

The Contractor may establish his own laboratory on site, or he may employ the services of an independent commercial laboratory. Whatever method is used, the Contractor must submit the results of tests carried out on materials and workmanship when submitting work for acceptance by the Engineer. The costs for these tests shall be deemed to be included in the relevant rates and no additional payment will be made for testing as required.

PS-6.5.2 Acceptance control

The process control test results submitted by the Contractor for approval of materials and workmanship may be used by the Engineer for acceptance control. However, before accepting any work, the Engineer may have further control tests carried out by a laboratory of his choice. The cost of such additional tests will be covered by a provisional sum provided in the schedule of quantities, but tests that failed to confirm compliance with the specifications, will be for the account of the Contractor.

**PS-6.6 Survey beacons** (Read with SANS 1921 - 1: 2004 clause 4.15)

The Contractor shall take special precautions to protect all permanent survey beacons or pegs such as benchmarks, stand boundary pegs and trigonometrical beacons, regardless whether such beacons or pegs were placed before or during the execution of the Contract. If any such beacons or pegs have been disturbed by the Contractor or his employees, the Contractor shall have them replaced by a registered land surveyor at his own cost.

**PS-6.7 Existing Services** (Read with SANS 1921 - 1: 2004 clause 4.17)

The Contractor shall make himself acquainted with the position of all existing services before any excavation or other work likely to affect the existing services is commenced.

The Contractor will be held responsible for any damage to known existing services caused by or arising out of his operations and any damage shall be made good at his own expense. Damage to unknown services shall be repaired as soon as possible and liability shall be determined on site when such damage should occur.

**PS-6.8 Management of the environment** (Read with SANS 1921 - 1: 2004 clause 4.19)

The Contractor shall pay special attention to the following:

(a) Natural Vegetation

The Contractor shall confine his operation to as small an area of the site as may be practical for the purpose of constructing the works.

Only those trees and shrubs directly affected by the works and such others as the Engineer may direct in writing shall be cut down and stumped. The natural vegetation, grassing and other plants shall not be disturbed other than in areas where it is essential for the execution of the work or where directed by the Engineer.

(b) Fires

The Contractor shall comply with the statutory and local fire regulations. He shall also take all necessary precautions to prevent any fires. In the event of fire, the Contractor shall take active steps to limit and extinguish the fire and shall accept full responsibility for damages and claims resulting from such fires which may have been caused by him or his employees.

**PS-6.9 Overhaul**

No payment will be made for overhaul on this contract unless provision is made thereof in specific items.

**PS-6.10 Excavations**

Due to the depths of sewer lines and their location nets to a water course, the Contractor is to allow in their tendered rates for excavation, for shoring and protection of trenches. No additional payment will be made for protection of excavations for whatever reason.

**PS-6.10 Security**

The Contractor shall provide security watchmen for the contract as he deems fit at no extra cost for the Employer. The Contractor must ensure that all his employees as well as the employees of his subcontractors are able to identify themselves as members of the construction team.

**PS-7 CONSTRUCTION PROGRAMME**

**PS-7.1 Preliminary programme**

The Contractor shall include with his tender a preliminary programme on the prescribed form to be completed by all Tenderers. The programme shall be in the form of a simplified bar chart with sufficient details to show clearly how the works will be performed within the time for completion as stated in the Contract Data.

The Contractor shall be deemed to have allowed fully in his tendered rates and prices as well as in his programme for all possible delays due to normal adverse weather conditions and special non-working days as specified in the Special Conditions of Contract, in the Project Specifications and in the Contract Data.

In determining his construction programme, the contractor should allow for disruptions/stoppages/requirements and intermittent "hold" of work while awaiting Engineer's inspections

The contractor must take into account the above requirements when pricing and preparing the programme of works. No additional payments, other than through scheduled items, will be made for these stoppages/disruptions/constraints.

Should the contractor fail to comply with these programme requirements, the Engineer, after giving 2 days' notice to the Contractor to comply, may order necessary work to ensure compliance, from another third party. This third party shall be paid from this contract from any monies due to the contractor.

**PS-7.2 Programme in terms of Clause 5.6 of the General Conditions of Contract**

It is essential that the construction programme, which shall conform in all respects to Clause 5.6 of the General Conditions of Contract, be furnished within the time stated in the Contract Data. The preliminary programme to be submitted with the tender shall be used as basis for this programme. The Contractor's attention is also drawn to Clause 5.7.1 of the General Conditions of Contract 2015.

**PS-8 SITE FACILITIES AVAILABLE**

**PS-8.1 Contractor's camp site and depot** (Read with SANS 1921 - 1 : 2004 clause 4.14)

The Contractor will be permitted to locate his offices, storage facilities, workshops, latrines, etc, on a site approved by the Engineer, in liaison with the community.

Temporary buildings and fencing are to be neat and presentable, and the surrounding areas must at all times be kept in a neat, clean and orderly condition. The Contractor must not cut down or damage any trees nor make any excavation without the written permission of the Engineer and will be required to restore the site to its original condition on completion of the Works.

All buildings and latrines shall be in accordance with the Local Authority and State Health regulations and shall be kept in a clean, sanitary condition to the satisfaction of the Engineer.

**PS-8.2 Accommodation of Employees**

No employees except for security guards will be allowed to sleep or be accommodated on the site in urban areas.

No housing is available for the Contractor's employees and the Contractor shall make his own arrangements to house his employees and to transport them to site.

No informal housing or squatting will be allowed.

The Contractor shall provide the necessary ablution facilities at his camp site and the site of the works for the use of his employees. Chemical toilets only will be allowed where temporary facilities must be provided.

**PS 8.3 Source of Water Supply**

The Contractor shall make his own arrangements for the supply of water for construction purposes. The source of water shall be subject to the approval of the Engineer.

The Water Services Authority in the area is Harry Gwala District Municipality. Should the contractor's source of water be the Harry Gwala District Municipality, the contractor will be required to ensure that the water account with the Harry Gwala District Municipality is in good standing prior to the issue of completion certificate. The Engineer will withhold any payments until arrears are cleared with The Harry Gwala District Municipality.

**PS 8.4 Source of Power Supply**

The power supply authority is Eskom. The Contractor will be required to make his own arrangements with, and pay all the requisite connection and consumption charges to Eskom for whatever temporary power supplies he/she may require for his use on the site and his tender will be held to include for all such costs and charges.

**PS-9 SITE FACILITIES REQUIRED**

## PS-9.1 Facilities Required for the Engineer

### PS 9.1.1 Temporary/Permanent Offices

The Contractor shall be asked to provide a temporary office for use by the Engineer. The offices should be able to accommodate one full time Engineer's Representative and two assistants. The offices should be approved pre-fabricated units or similar equivalent with the following minimum specification:

- Exterior should be of chromadek make with a chromadek roof. Windows should be of aluminium and doors to be chromadek
- Interior should include oak ply cladding with vinyl flooring. Ceiling is to be white vinyl
- Air conditioning is to be provided

The Engineer's offices are to be equipped with the following as a minimum:

- Three desks each with lockable drawers
- Three high back swivel chairs
- Three visitors chairs
- A facility to store/hang drawings
- An electric refrigerator of at least 200 litres capacity

The Contractor should also make arrangements for covered facilities to enable the accommodation of approximately 12– 16 people during progress site meetings, to be held fortnightly or monthly.

***The facilities are to be provided, to the satisfaction of the Engineer, within 14 days of commencement date. Should the contractor fail to provide approved establishment within the stipulated 14 days, the contractor will pay a penalty calculated as follows:***

- ***Mileage of the Engineer's Representative from other offices from the nearest business centre to site and back to office at R4.00/km***
- ***Rented Office space equivalent to that stipulated in this contract at offices in uMzimkhulu town or other place closer to the site.***

***This penalty shall be deducted from the Contractor's payment certificates and paid to the service provider providing the site office of the specification as detailed above.***

### PS 9.1.2 Laboratory Facilities

The Contractor will not be required to provide a testing laboratory on site for use by the Engineer. However, the contractor will be required to provide compaction test results for all backfilling across roads from a recognised laboratory. The contractor will also be required to provide concrete cube test results from a recognised / approved laboratory. No additional payment will be made for the compaction or concrete cube tests and the contractor is to allow for the costs thereof in the tendered rates.

### PS 9.1.3 Sanitary Facilities

All latrines shall conform to the requirements of the Local Authority and shall be subject to approval by the Engineer. All sanitary fees and charges due under the Local Authority or State Health Regulations or bylaws shall be paid by the Contractor. Throughout the progress of the contract, all latrines shall be maintained by the Contractor in a clean, sanitary condition to the satisfaction of the Engineer.

### PS 9.1.4 Telephone Facilities

The Contractor will not be required to provide a telephone for use by the Engineer. The contractor will however be required cover cellphone costs for the engineer's site staff for airtime valued at R150/week. Appropriate items have been provided in the Schedule of Quantities to cover these costs.

**PS 9.1.5 Housing Facilities**

The Contractor will not be required to provide housing facilities for the Engineer's staff. However, a provisional sum has been provided in the schedule of quantities for payment through the contract for accommodation for the Engineer's staff.

**PS 9.1.6 Parking Facilities**

The Contractor will be required to provide two covered parking bay for the Engineer.

**PS 9.1.7 Engineer's Transport**

The Contractor will not be required to provide transport for the Engineer's staff.

**PS 9.1.8 Security**

The Contractor will be responsible for providing adequate security for the Works and for the site establishment. All costs associated with the provision of security staff shall be borne by the Contractor and should allowed for in the rates tendered for items in the Schedule of Quantities. No additional payments will be made for security measures taken during the contract period, other through the schedule items in the Schedule of Quantities.

**PS 9.1.9 Contract staff to assist the Engineer**

The following staff will be recruited by the contractor to assist the Engineer in carrying out his services:

Description of Staff	N° Required	Remarks
Environmental Monitoring	N/A	Provisional sum provided for appointment as directed by the Engineer. Personnel directed by and report to Engineer
Occupational Health & Safety Monitoring	One	
Technical Assistant	One	
Geotechnical Consultant	One	
Community Liaison Officer	One	

The required personnel will be identified by the Engineer or Employer as the case may be, and will report to the Engineer. Provisional Sums and the relevant mark-up Items are provided for in the Schedule of Quantities to cover these costs.

**PS 9.1.10 Survey Equipment**

The contractor shall provide the following survey equipment, in good condition, for use by the Engineer throughout the duration of the contract:

- A dumpy level
- A theodolite
- 100 m measuring tape
- An assistant, when required, to assist the Engineer to operate survey equipment, when provided.



**PS 10. EXISTING SERVICES**

**PS 10.1 Care, Damage and Protection**

Known services will be indicated in the tender and contract documents. The Contractor will be responsible for identifying all services with the relevant Service Providers.

The Contractor shall familiarize himself with all services and expose them at the start of the Contract to verify their position and establish their depths.

No additional payment will be made to the Contractor for identifying and locating services. Therefore, the Contractor will have to include the costs thereof in the scheduled items in the Schedule of Quantities.

Any information regarding existing services is given in good faith and without guarantee.

**PS 10.2 Blasting**

No blasting will be permitted unless the Contractor can satisfy the Engineer that his proposed blasting methods and controls are such that no damage will be caused to the adjoining building structures, pipelines or services. In any event the Engineer will require the Contractor to plan and execute each blast in such a manner as to ensure that no damage will be caused to any structure, pipeline or service. In addition, the Engineer will require vibro-recordings to be taken at no additional cost to the Employer. No blasting is to be carried out in Eskom servitudes or wayleaves unless the Eskom authorities have been advised in writing three weeks prior to blasting. Where blasting is done adjacent to Eskom power lines, the Contractor shall arrange for a representative of Eskom to be present prior to and during any blast.

**PS 10.3 Environmental Aspects**

The Contractor will be required to plan and undertake his work in a manner that minimises its impact on the natural environment. Trees and other vegetation shall, wherever possible, be left undisturbed. Trees that are marked by the Engineer shall not be damaged and in the event of the Contractor doing so, a penalty will be deducted from monies due to the Contractor.

Every effort shall be made by the Contractor to prevent pollution of the adjacent areas and river and to reduce the noise, dust and fumes emanating from his construction activities.

**PS 10.4 Dealing with Water**

Where necessary, the Contractor shall construct temporary drainage channels to divert ground water from his excavation and excess water must be pumped out.

No compensation for any variation of the actual conditions during construction from the data given will be considered. Neither will additional compensation be considered for data omitted or inaccurately given.

The rates tendered shall allow for the requirements of this clause and all incidentals.

**PS 10.5 Servitudes and Rights of Way**

The Employer will, where necessary, obtain permanent servitudes and rights of way along the road routes indicated on the tender drawings. New servitudes will only be registered after completion of the Works.

**PS 10.6 Dealing with Damaged Services**

In the event of any service being damaged or accidentally disconnected for any reason, the Contractor shall immediately contact the relevant authority for instruction and shall report the occurrence of the incident. The damage is to be repaired as soon as possible to the approval of the Engineer and the authority. The Contractor will be held responsible for paying all costs incurred by the authority or himself as a result of each such incident, where relevant.

**PS 10.7 Accommodation of Traffic**

The Contractor shall always ensure the safe and expeditious passage of traffic and shall provide all necessary temporary road traffic signs, barricades, flagmen, etc to safeguard the travelling public. Any detours or bypasses constructed by the Contractor shall be adequately signposted, as per the South African Road Traffic Signs Manual, and maintained in such a manner as to provide safe and easy passage of traffic.

**PS 10.8 Spoil Material**

No indiscriminate spoiling of material will be allowed. All surplus or unsuitable material shall be spoiled, levelled and spread in designated areas as directed by the Engineer. All haul will be regarded as freehaul.

**PS 10.9 Finishing and Tidying and Defects Liability Period**

On no account must rubble and spoil materials, other materials, equipment or unfinished operations be allowed to accumulate in such a manner as to unnecessarily impede the activities of other Contractors or Authorities.

Finishing and tidying must not simply be left until the end of the construction period. The Contractor will be entitled, subject to prior agreement with the Engineer and within reasonable limits, to request that work in a particular area and/or work of a particular discipline, be inspected for partial completion. The specified defects liability period in respect of any specific section of the Works shall commence on the date on which the relevant section is accepted by the Engineer as being completed, i.e. fully commissioned, including finishing and tidying.

On completion of the Contract the Contractor shall ensure that all materials used in the construction of the temporary Site office, workshop and storage yard are removed from Site. Waste materials such as construction debris and soil contaminated with oil and fuel are to be disposed of at the solid waste disposal site used approved by the Engineer. Prior to the handover of the Site to the Employer, the Contractor and the Engineer will conduct a post construction audit to determine if any additional measures that are to be taken. The Completion Certificate will only be issued after this stage.

**PS 10.10 Employee Accommodation**

(See Subclause 3.2.1 of Section A of Part 2 and Subclause 1.2.1 of Section A of Part 3 of SABS 0120)

The Contractor shall conform in all respects with the provisions of any Act, Regulations or By-Law of Harry Gwala District Municipality, which may be applicable to employee accommodation. Save for a security guard on active duty, no employees may be housed on Site or the Contractor's campsite after normal working hours.

**PS 10.11 Employment of Local Labour**

The Employer has determined that 100% of the Contractor's unskilled labour force shall be made up from the local community. A labour sub-committee (of a Project Steering Committee) comprising representatives of the community and other stakeholders will be responsible for the recruitment of all local labour. The Contractor will be required to provide details of the numbers of semi-skilled and unskilled workers he will require, together with their anticipated starting dates. The PSC through its labour sub-committee will then make this labour available to the Contractor.

A minimum of 50% of the local labour shall comprise of women and, where appropriate, disabled labour shall be employed. It is a requirement that tenderers acquaint themselves fully with requirements for registration with Unemployment Insurance Fund.

The Employer requires that the successful contractor registers all labour with the Unemployment Insurance Fund. The local labour rate has been determined at R200.00/day per labourer. The task for excavation by hand has been agreed at 2,4 m<sup>3</sup>/day (e.g. 0,76 m x 1,0 m x 3,15 m).

During project execution, the successful contractor will be required to provide progress reports indicating to what level these requirements have been met.

#### **PS 10.12 EPWP Construction Methods**

EPWP construction methods will be utilised on this contract in order to generate employment opportunities for the local community.

#### **PS 10.13 Frequency of Labour Wages Payments**

The contractor will be required to pay labour on a fortnightly basis.

#### **PS 10.14 Training and Capacity Building**

During project execution, it is the desire of the Employer that an identified number of community members receive appropriate level of non accredited training in either pipelaying activities or construction management activities. Within 14 days of appointment, the successful contractor will be required to provide, together with his method statement, a proposal for consideration by the Project Steering Committee for activities in which the community members can receive training. This proposal will be considered by the Project Steering Committee after which the Contractor will be given an instruction on the training to provide. Training will be provided to local labour that is already in the employ of the contractors as per clause PS 10.11. It must be noted that the Contractor will be required to pay the labour based on their daily rates indicated in PS 10.11.

A minimum of 20 person-days should be provided as non-accredited training. The contractor will be required to provide a training diary and report indicating the following to be updated monthly:

- Details of persons receiving training
- What areas there have been trained in
- Performance of the trainees
- Further training still to be done

Should the contractor fail to provide this training, the Employer reserves the right to seek training from alternative sources. In that case, the cost of the training sought will be deductible from any monies due to the contractor.

#### **PS 10.15 Contractor Participation Goal (CPG) Partner**

The Employer will require that the contractor utilise a CPG partner on the contract as part of development of emerging contractors. The CPG partner will be approved by the Employer and will be required to undertake up to 30% of the scope of work. Should the contractor be unable to provide

a CPG partner, the Employer will provide one on the contract. Tenderers are also referred to Contract Data, Clause 4.4.7 in this regard.

**PS-11 REQUIREMENTS FOR ACCOMMODATION OF TRAFFIC**

**PS-11.1 General**

The Contractor will be responsible for the safe and easy passage of public traffic past and on sections of roads of which he has occupation or where work has to be done near traffic.

Accommodation of traffic, where applicable shall comply with SANS 1921-2: 2004: Construction and Management Requirements for Works Contracts, Part 2: Accommodation of Traffic on Public Roads occupied by the Contractor. The Contractor shall obtain this specification from Standards South Africa if accommodation of traffic will be involved on any part of the construction works.

**PS-11.2 Basic Requirements**

The travelling public shall have the right of way on public roads, and the Contractor shall make use of approved methods to control the movement of his equipment and vehicles so as not to constitute a hazard on the road.

The Contractor shall ensure that all road signs, barricades, delineators, flagmen and speed controls are effective, and that courtesy is always extended to the public.

Failure to maintain road signs, warning signs or flicker lights, etc, in a good condition shall constitute ample reason for the Engineer to suspend the work until the road signs, etc, have been repaired to his satisfaction.

The Contractor may not commence constructional activities affecting existing roads before adequate provision has been made to accommodate traffic in accordance with the requirements of this document and the South African Road Traffic Signs Manual.

The Contractor shall construct and maintain all temporary drainage works necessary for temporary deviations.

The Contractor shall provide and grant access to persons whose properties fall within or adjoin the area in which he is working.

**PS-11.3 Traffic Safety Officer**

Where warranted by traffic conditions on or near the site, the Contractor shall nominate a suitable member of his staff as traffic safety officer to be responsible for the arrangement and maintenance of all the measures for the accommodation of traffic for the duration of the project. Duties of the traffic safety officer shall be as set out in SANS 1921 Part 2 and shall also comply with the Occupational Health and Safety Act No 85 of 1993 and the Construction Regulations 2014.

**PS-11.4 Payment**

The Contractor's tendered rates for the relevant items in the Bill of Quantities shall include full compensation for all possible additional costs which may arise from this, and no claims for extra payment due to inconvenience as a result of the modus operandi will be considered.

Items that may be considered for payment are specified in SABS 1200 Standardized Specifications and the related project specification.

**PS-12 OCCUPATIONAL HEALTH AND SAFETY (Read with SANS 1921 - 1: 2004 clause 4.14)**

**PS-12.1 General statement**

It is a requirement of this contract that the Contractor shall provide a safe and healthy working environment and to direct all his activities in such a manner that his employees and any other persons, who may be directly affected by his activities, are not exposed to hazards to their health and safety. To this end the Contractor shall assume full responsibility to conform to all the provisions of the Occupational Health and Safety Act No 85 and Amendment Act No 181 of 1993, and the OHS Act 1993 Construction Regulations 2014 issued by the Department of Labour.

For the purpose of this contract the Contractor is required to confirm his status as mandatory and employer in his own right for the execution of the contract by entering into an agreement with the Employer in terms of the Occupational Health and Safety Act by executing the Agreement form C1.2.4 included in Section C1: Agreements and Contract Data.

**PS-12.2 Health and Safety Specifications and Plans to be submitted at tender stage**

(a) Employer's Health and Safety Specification

The Employer's Health and Safety Specification will be included in the tender documents as part of the Project Specifications.

(b) Tenderer's Health and Safety Plan

The successful Tenderer shall, on receipt of notification that he has been awarded the contract, submit without delay his own documented Health and Safety Plan for the execution of the work under the contract. His Health and Safety Plan must at least cover the following:

- (i) a proper risk assessment of the works, risk items, work methods and procedures in terms of Regulations 7 to 28;
- (ii) pro-active identification of potential hazards and unsafe working conditions;
- (iii) provision of a safe working environment and equipment;
- (iv) statements of methods to ensure the health and safety of subcontractors, employees and visitors to the site, including safety training in hazards and risk areas (*Regulation 5*);
- (v) monitoring health and safety on the site of works on a regular basis, and keeping of records and registers as provided for in the Construction Regulations;
- (vi) details of the Construction Supervisor, the Construction Safety Officers and other competent persons he intends to appoint for the construction works in terms of Regulation 6 and other applicable regulations; and
- (vii) details of methods to ensure that his Health and Safety Plan is carried out effectively in accordance with the Construction Regulations 2014.

The Contractor's Health and Safety Plan will be subject to approval by the Employer, or amendment if necessary, before commencement of construction work. The Contractor will not be allowed to commence work, or his work will be suspended if he had already commenced work, before he has obtained the Employer's written approval of his Health and Safety Plan.

Time lost due to delayed commencement or suspension of the work as a result of the Contractor's failure to obtain approval for his safety plan, shall not be used as a reason to claim for extension of time or standing time and related costs

**PS-12.3 Cost of compliance with the OHS Act Construction Regulations**

The rates and prices tendered by the Contractor shall be deemed to include all costs for conforming to the requirements of the Act, the Construction Regulations and the Employer's Health and Safety Specification as applicable to this contract. Should the Contractor fail to comply with the provisions

of the Construction Regulations, he will be liable for penalties as provided in the Construction Regulations and in the Employer's Health and Safety Specification.

Items that may qualify for remuneration will be specified in the Safety Specifications included or in the Project specifications.

**PS-13 ADVERSE WEATHER CONDITIONS**

In terms of Clause 5.12.2 of the General Conditions of Contract, extension of time will be considered for **abnormal rainfall**. The numbers of days per month on which work is expected not to be possible as a result of **normal rainfall**, and for which the Contractor shall make provision in his tendered rates, prices and programme, are listed in Table PS-13 hereafter. Only the number of days lost as a result of adverse weather conditions, exceeding the number of days listed in Table PS-13.1, will qualify for consideration of extension of time.

During the execution of the Works, the Engineer's Representative will certify a day lost due to abnormal rainfall and adverse weather conditions only:

- if no work was possible on the relevant working day on any item which is on the critical path according to the latest approved construction programme; or
- if less than 30% of the work force and plant on site could work during that specific working day.

Extension of time as a result of abnormal rainfall and adverse weather conditions shall be calculated monthly being equal to the number of working days certified by the Engineer's Representative as lost due to rainfall and adverse weather conditions, less the number of days allowed for as in Table PS-13, which could result in a negative figure for certain months. The total extension of time as a result of abnormal climatic conditions for which the Contractor may apply, shall be the cumulative algebraic sum of the monthly extensions. Should the sum thus obtained be negative, the extension of time shall be taken as nil."

**Table PS-13: Expected N° of Working Days Lost Monthly Due to Normal Rainfall**

MONTH	Expected number of working days lost as result of normal rainfall
JANUARY	*5
FEBRUARY	5
MARCH	4
APRIL	1
MAY	1
JUNE	1
JULY	1
AUGUST	1
SEPTEMBER	2
OCTOBER	3
NOVEMBER	4
DECEMBER	5
<b>TOTAL</b>	<b>33 days</b>

*(Based on information obtained from the Weather Bureau, Department of Environment Affairs, Margate. The average monthly rainfall figures quoted, are included for information only, and shall not be taken into consideration for calculation of extension of time. The number of working days lost for December and January allows for the builders' holidays from 21 December 2015 and ending on 08*

January 2016.)

**PS-14 SITE MEETINGS AND REPORTING**

The Contractor will be required to attend site meetings organised by the Engineer. In these meetings he (the Contractor) will be required to provide progress reports and other reports to monitor the outputs of the contractor, as may be required from time to time, to be presented in a format prescribed by the Engineer. The frequency of such meetings will be monthly, as a minimum. However, the frequency can be reviewed, depending on the progress of the contract.

**PS-15 PREFERENTIAL PROCUREMENT**

For the purpose of this contract the Contractor shall comply with the preferential procurement statement provided in F.3.11 and T2.2 of the Tender Data.

**PS-16 EPWP SPECIFICATION**

**PS-16.1 Labour Intensive Competencies of Supervisory and Management Staff**

Contractors shall only engage supervisory and management staff in labour intensive works that have completed the skills programme outlined in Table 1:

**Table 1: Skills programme for supervisory and management staff**

Personnel	NQF level	Unit standard titles	Skills programme description
Foreman / Supervisor	4	Implement Labour-Intensive Construction Systems and Techniques.	This unit standard must be completed, <b>and</b>  any one of these 3 unit standards
		Use Labour-Intensive Construction Methods to Construct and Maintain Roads and Stormwater Drainage	
		Use Labour-Intensive Construction Methods to Construct and Maintain Water and Sanitation Services	
		Use Labour-Intensive Construction Methods to Construct, Repair and Maintain Structures	
Site Agent / Manager (i.e. the contractor's most senior representative that is resident on the site)	5	Manage Labour-Intensive Construction Processes	Skills Programme against this single unit standard

**PS-16.2 Employment of Unskilled and Semi-Skilled Workers in Labour-Intensive Works**

**PS-16.2.1 Requirements for the sourcing and engagement of labour.**

**PS-16.2.1.1 The overall youth target is 55%; women 60% and people with disabilities is 2%.**

EPWP Reporting procedure: Employment contracts, ID Copies, Payment register, Attendance registers must be attached on every claim that is submitted by the contractor. Contractor must ensure that this information is submitted every month for reporting and compliance purposes. The contractor's invoices shall not be paid until all pending labour information has been submitted.

Unskilled and semi-skilled labour required for the execution of all labour-intensive works shall be engaged strictly in accordance with prevailing legislation in accordance with the Code of Good Practice for the Expanded Public Works Programme.

**PS-16.2.1.2 The following are some of the considerations that are elaborated in the Code of Good Practice for Expanded Public Works Programmes.**

**PS-16.2.2 Training of Targeted Labour**

**PS-16.2.2.1** The contractor shall provide all the necessary on-the-job training to targeted labour to enable such labour to master the basic work techniques required to undertake the work in accordance with the requirements of the contract in a manner that does not compromise worker health and safety.

**PS-16.2.2..2** Accredited training may be provided before the commencement of a project.

**PS-16.2.2.3** The cost of accredited training of targeted labour will be funded through various funding sources such as National Skills Fund from the Department of Higher Education and Training, funds from the Implementing Public body, funding from SETAS etc. This training should take place as close to the project site as practically possible. The Public Body implementing the project must ensure that training applications for beneficiaries are made by its relevant project manager assisted by relevant training officials from the National Department of Public Works.

**PS-16.2.2.4** The Public Body must ensure that preference of the training of beneficiaries in technical skills over life skills is made. In addition, the Public Body is required to maximize opportunities for training to beneficiaries to be carried out before the implementation of projects.

**PS-16.2.2.5** The Public body must ensure that workers who have received training will be placed on the project to work after receiving the training.

**PS-16.2.2.6** If a provisional sum for training is made in the contract the contractor shall pay an allowance equal to 100% of the daily wage rate to workers who attend accredited training.

**PS-16.3 Generic Labour-Intensive Specification**

The Generic Labour-intensive specification below (informed by SANS 1921-5, Construction and management requirements for works contracts - Part 5: Earthworks) covers activities which are to be performed by hand and should be included in the scope of works without amendment or modification as set out below.

This specification establishes general requirements for activities which are to be executed by hand involving the following:

- trenches having a depth of less than 1.5 metres
- stormwater drainage
- low-volume roads (typically less than 500 vehicles per day);
- sidewalks and non-motorised transport infrastructure
- water and sanitation

**PS-16.3.1 Precedence**



Where this specification is in conflict with any other standard or specification referred to in the Scope of Works to this Contract, the requirements of this specification shall prevail.

**PS-16.3.2 Hand excavatable material**

Hand excavatable material is:

**a) granular materials:**

- i) whose consistency when profiled may in terms of table 2 be classified as very loose, loose, medium dense, or dense; or
- ii) where the material is a gravel having a maximum particle size of 10mm and contains no cobbles or isolated boulders, no more than 15 blows of a dynamic cone penetrometer is required to penetrate 100mm;

**b) cohesive materials:**

- i) whose consistency when profiled may in terms of table 2 be classified as very soft, soft, firm, stiff and stiff / very stiff; or
- ii) where the material is a gravel having a maximum particle size of 10mm and contains no cobbles or isolated boulders, no more than 8 blows of a dynamic cone penetrometer is required to penetrate 100mm;

**Note**

1. A boulder is material with a particle size greater than 200mm, a cobble and gravel is material between 60 and 200mm.
2. A dynamic cone penetrometer is an instrument used to measure the insitu shear resistance of a soil comprising a drop weight of approximately 10 kg which falls through a height of 400mm and drives a cone having a maximum diameter of 20mm (cone angle of 60° with respect to the horizontal) into the material being used.

<b>Table 2: Consistency of materials when profiled</b>			
<b>GRANULAR MATERIALS</b>		<b>COHESIVE MATERIALS</b>	
<b>CONSISTENCY</b>	<b>DESCRIPTION</b>	<b>CONSISTENCY</b>	<b>DESCRIPTION</b>
Very loose	Crumbles very easily when scraped with a geological pick.	Very soft	Geological pick head can easily be pushed in as far as the shaft of the handle.
Loose	Small resistance to penetration by sharp end of a geological pick.	Soft	Easily dented by thumb; sharp end of a geological pick can be pushed in 30-40 mm; can be moulded by fingers with some pressure.
Medium dense	Considerable resistance to penetration by sharp end of a geological pick.	Firm	Indented by thumb with effort; sharp end of geological pick can be pushed in upto 10 mm; very difficult to mould with fingers; can just be penetrated with an ordinary hand spade.

Dense	Very high resistance to penetration by the sharp end of a geological pick; requires many blows for excavation.	Stiff	Can be indented by thumb-nail; slight indentation produced by pushing geological pick point into soil; cannot be moulded by fingers.
Very dense	High resistance to repeated blows of a geological pick.	Very stiff	Indented by thumb-nail with difficulty; slight indentation produced by blow of a geological pick point.

**PS-16.3.3 Trench excavation**

All hand excavatable material in trenches having a depth of less than 1,5 metres shall be excavated by hand.

**PS-16.3.4 Compaction of backfilling to trenches (areas not subject to traffic)**

Backfilling to trenches shall be placed in layers of thickness (before compaction) not exceeding 100mm. Each layer shall be compacted using hand stampers

- a) to 90% Proctor density;
- b) such that in excess of 5 blows of a dynamic cone penetrometer (DCP) is required to penetrate 100 mm of the backfill, provided that backfill does not comprise more than 10% gravel of size less than 10mm and contains no isolated boulders, or
- c) such that the density of the compacted trench backfill is not less than that of the surrounding undisturbed soil when tested comparatively with a DCP.

**PS-16.3.5 Excavation**

All hand excavatable material including topsoil classified as hand excavatable shall be excavated by hand. Harder material may be loosened by mechanical means prior to excavation by hand.

The excavation of any material which presents the possibility of danger or injury to workers shall not be excavated by hand.

**PS-16.3.6 Clearing and grubbing**

Grass and small bushes shall be cleared by hand.

**PS-16.3.7 Shaping**

All shaping shall be undertaken by hand.

**PS-16.3.8 Loading**

All loading shall be done by hand. Haulage equipment should be selected in a manner that allows loading by hand to the extent possible.

**PS-16.3.9 Haul**

Excavation material shall be hauled to its point of placement by means of wheelbarrows where the haul distance is not greater than 150 m.

**PS-16.3.10 Offloading**

All material, however transported, is to be off-loaded by hand, unless tipper-trucks are utilised for haulage.

**PS-16.3.11 Spreading**

All material shall be spread by hand.

**PS-16.3.12 Compaction**

Small areas may be compacted by hand provided that the specified compaction is achieved. Appropriate rollers should be used where higher (than can be achieved by hand) levels of compaction are required.

**PS-16.3.13 Grassing**

All grassing shall be undertaken by sprigging, sodding, or seeding by hand.

**PS-16.3.14 Stone pitching and rubble concrete masonry**

All stone required for stone pitching and rubble concrete masonry, whether grouted or dry, must be collected, loaded, off loaded and placed by hand.

Sand and stone shall be hauled to its point of placement by means of wheelbarrows where the haul distance is not greater than 150m.

Grout shall be mixed and placed by hand.

**PS-16.3.15 Manufactured Elements**

Elements manufactured or supplied by the Contractor, such as manhole rings and cover slabs, precast concrete planks and pipes, masonry units and edge beams shall not individually, have a mass of more than 320kg. In addition, the items shall be large enough so that four workers can conveniently and simultaneously acquire a proper hand hold on them.

**PS 17 SUBCONTRACTING OF A PORTION OF THE CONTRACT**

The successful Tenderer will be required to employ local and disabled people and moreover, subcontract up to a maximum of 30% of the project value to local contractors. The "local contractors" will be located in the Harry District Municipality area of jurisdiction and where specifically required by the Employer, the area where construction works are being undertaken.

Also refer to Contract Data.

**PROJECT SPECIFICATION: PORTION 2**

**AMENDMENTS TO THE STANDARD AND PARTICULAR SPECIFICATIONS**

**INTRODUCTION**

In certain clauses the standard, standardized and particular specifications allow a choice to be specified in the project specifications between alternative materials or methods of construction and for additional requirements to be specified to suit a particular contract. Details of such alternative or additional requirements applicable to this contract are contained in this part of the project specifications. It also contains additional specifications required for this particular contract.

The number of each clause and each payment item in this part of the project specifications consists of the prefix PS followed by a number corresponding to the number of the relevant clause or payment item in the standard specifications. The number of a new clause or payment item, which does not form part of a clause or a payment item in the standard specifications and which is included here, is also prefixed by PS, but followed by a new number which follows on the last clause or item number used in the relevant section of the standard specifications.

**PROJECT SPECIFICATION: PORTION 2**  
**SABS 1200 PSA: GENERAL**

**PS A 3 MATERIALS**

All the Contractor's suppliers are to be approved and inspected by the Engineer before they are engaged.

**PS A 3.1 QUALITY**

Where there is a standardised mark programme for any material, all such material supplied shall bear the official standardisation mark. The Engineer's approval is based on tests conducted by the Contractor as required by this Contract.

All materials proposed by the Contractor for incorporation into the work shall where required, be tested in accordance with the Specification. The Contractor is responsible for the cost of all testing to ascertain that the materials do comply with the relevant minimum requirements and all such costs shall be deemed to be included in the tendered rates. The cost of control tests done by the Engineer and for which the result to not comply with the minimum requirements shall be for the Contractor's account.

All test results shall be submitted to the Engineer for approval prior to such materials being built into the works. No material shall be built into the works without such approval. All costs involved in this testing shall be deemed to be included in the rates tendered.

The Contractor shall inform the Engineer of any control testing to be done at least 48 hours before such tests are required and must allow in his program for the time necessary for the tests and the processing of the results thereof.

The handling, storage, transport and erection of equipment, machinery and materials shall be strictly in accordance with the requirements of the supplier and/or manufacturer.

All materials shall be new and of the best quality available unless otherwise specified. They must function satisfactorily under the prevailing climate and weather conditions at the place of installations.

The Contractor is totally responsible for the implementation of an approved QA system equivalent to ISO 9000. The system shall be submitted to the Engineer for approval within 14 days of the start of the Contract and shall define methods to ensure that all necessary quality standards are attained. The Engineer will audit the applications of the QA system on a regular basis during this Contract.

**PSA 4 PLANT**

*All plant provided by the Contractor for the execution and maintenance of the works shall be of a character comparable with the scope of the works.*

The Contractor shall provide and maintain sufficient plant to meet all contractual requirements and shall not remove any of this plant from the site without the written permission of the Engineer. He shall, however, remove unsuitable, obsolete or worn-out plant from the site when ordered to do so by the Engineer and replace these with plant approved by the Engineer.

The approval of any plant on the site by the Engineer shall in no way relieve the Contractor of any of his obligations under the Contract.

**PS A 4.2 Contractor's Offices, Stores and Resources**

Add the following to A 4.2:

No housing is available for the Contractor's employees and the contractor must make his own arrangements for accommodation and transport of his employees.

**PS A 4.3 Hand Tools**

The contractor shall provide and maintain all hand tools required for the execution of the Works.

**PS A 5 CONSTRUCTION**

*On completion of the scope of work associated with each construction drawing, the Contractor shall provide a marked-up "as-built" copy of the drawing. These drawings shall incorporate all changes, amendments and additions that have occurred and the drawings shall be signed by the Contractor's representative and submitted to the Engineer for signature and acceptance.*

Where surveying is necessary to determine as-built conditions, the Contractor shall provide a land surveyor on Site to undertake the as-built survey within 24 hours of being so instructed by the Engineer.

**PS A 5.1. Survey**

**PS A 5.1.1 Setting out of the Works**

Substitute the first sentence in A 5.1.1 with the following:

Setting out of the work is the sole responsibility of the Contractor and shall be done from the layouts given to him. The proposed network pipes must be placed 2,0m away from the ERF boundaries in the road reserve. Any discrepancy shall immediately be reported in writing to the Engineer. Any costs or subsequent costs arising from discrepancies, which had not been reported to the Engineer, shall be the sole responsibility of the Contractor. The exact position of the network pipes shall be determined on site in conjunction with the Engineer and must be approved before construction of the specific section starts.

The Engineer may alter any part of the works to suit the local conditions. The Contractor must therefore contact the Engineer immediately after the preliminary setting out of any part of the works before starting with detail setting out, or construction. Only after the Engineer has approved a specific site or part of works, may the detail setting out and construction commence.

**PS A 5.2 Watching, Barricading, Lighting And Traffic Crossings**

Add the following to A 5.2.

The crossing of existing tar and dirt roads must be done in half widths, while the total traffic is accommodated on the other lane.

Road traffic signs shall comply with the requirements of the "South African Road Traffic Signs Manual" and shall be approved by the Engineer before construction commences.

**PS A 5.9 Transporting Of Materials**

Where the transporting of materials outside of the site is such as to generate a nuisance, the material shall be covered during transport.

Precautions shall be taken during the transporting of muddy and other materials to prevent its fouling completed construction or roads. Any rock or debris falling from trucks on to roads shall be removed immediately.

*Access Roads to Site - The Contractor shall keep in good and constant repair all access roads to and on the site.*

Any route that the Contractor wishes to use to the place where water is obtained or any other route that is used by the Contractor shall be subject to approval by the Engineer. All the Contractor's vehicles on the Site must be in a roadworthy condition. The number of the Contractor's vehicles on the Site will be subject to approval by the Engineer.

## **PS A 7 TESTING**

### **PS A 7.2 Approved Laboratories**

The Contractor may appoint an accredited independent testing laboratory to the approval of the Engineer. The Engineer shall be given free access to any appointed laboratory.

### **PS A 7.4 Statistical Analysis of Control Tests**

Substitute A 7.4 with the following:

Test results shall not be evaluated by statistical methods. All results shall comply with the specified minimum requirements of the materials concerned.

## **PS A 8 MEASUREMENT AND PAYMENT**

### **PS A 8.1.2.3 The Contractor to Price all Items**

In addition, the *Contractor* shall provide a detailed schedule itemising the breakdown of each item listed in the Preliminary and General section of the Schedule of Quantities, in terms of all personnel, plant, structures, facilities etc. not covered by the construction rates elsewhere in the schedule. The rate for each item in the detailed schedule shall cover all direct and overhead costs, profit and all other costs for provision of the item.

### **PS A 8.2.2 Time-Related Items**

The tendered amount for a time-related item will be increased; if any extension of time for the completion of the works is awarded on the condition that the activity related to the item tendered for must be sustained during the extended period.

The ratio between the increased amount for a time-related item and the tendered amount must be the same as the ratio between the extension of the time period for the completion of the works and the original time period allowed for completion of the works.

If the works is completed before the end of the original time period allowed for completion of the works, the tendered amount of time related item that is influenced by the earlier completion would be reduced similarly.

**PS A 8.3 Fixed Charge and Value-Related Items**

**PS 8.3.1 Contractual Requirements ..... Unit: Sum**

The sum shall cover the Contractor’s initial costs of providing sureties, insurance of the works and plant, third party or public liability insurance and unemployment insurance to cover his compliance with the requirements of the Workmen’s Compensation Act, 1941 (Act No. 30 of 1941) and any other initial financing obligations of a preliminary and general nature, such contributions of the CEITB.

The tendered amounts for fixed charge and value related items will not be increased, if extension of time for the completion of the works is awarded.

**PS A 8.3.2 Establishment of Facilities on the Site**

**PS A 8.3.2.1 Facilities for Engineer**

- a) Furnished office (No) Unit: Sum
- b) Communication Costs (No) Unit: Sum
- c) Nameboards (No) Unit: Sum
- d) Computer facilities complete with printer, modem with 4G connection (No) Unit: Sum
- e) Provision of survey equipment (No) Unit: Sum

**PS A 8.3.2.2 Facilities for Contractor**

- a) Offices and storage sheds Unit: Sum
- b) Workshops Unit: Sum
- c) Laboratories Unit: Sum
- d) Ablution and latrine facilities Unit: Sum
- e) Tools and equipment Unit: Sum
- f) Water supplies, electric power and communications Unit: Sum
- g) Dealing with water Unit: Sum
- h) Access Unit: Sum
- i) Plant Unit: Sum

**PS A 8.3.3. Other Fixed Charge Obligations**

This item as listed under Schedule A of the Bill of Quantities is as specified in the standardized specification SANS 1200 A.

**PSA 8.3.3.1**

Issuing of notices to consumers Unit: Sum

**PSA 8.3.3.2 OHS Act Obligations**

- I. General Safety obligations (incl. provision of personal protective equipment) Unit: Sum
- II. Health and Safety plan/file including health and safety training Unit: Sum

**PSA 8.3.3.3**

Environmental Management Plan Obligations Unit: Sum

**PS A 8.3.4 Removal of Site Establishment**

The sum shall cover the cost of the demolition on and the removal from the surface of the site of all items established in terms of 8.3.2 and 8.3.3, and shall provide for the making good and the restoring of the site to the satisfaction of the Engineer.



**PS A B 8.3.5 Occupational Health And Safety**

**PS A B.8.3.5.1 Contractor's initial obligations in respect of the Occupation Health and Safety Act and Contractual Regulations .....Unit: Sum**

The amount will be paid on the scheduled rate on condition that:

- The contractor has notified the Provincial Director of the Department of Labour in writing of the project.
- The client has approved the contractor's Health and Safety Plan.
- The contractor has set up his Health and Safety File and Safety Plan.
- The contractor has appointed a Health and Safety Officer.

The provisional sum shall represent full compensation for that part of the contractor's general obligations in terms of Occupational Health and Safety Act and the Construction Regulation which are mainly a function of time. The sum for the supply of all safety clothing, first aid kit, etc. in order to adhere to the occupational Health and Safety Act specifications. The Contractor must familiarize himself with the conditions as per Occupational Health and Safety Act and adhere thereto. The rate shall cover the Contractor's overheads, changes, and profit payments for the service Provider. Contractor to note that this item covers the costs for the preparation and submission of Health and Safety plan and file.

Payment shall be as specified for item 1.3 in the standard specifications.

**PS A B.8.3.5.2 Occupational Health and Safety Act ..... Unit: Sum**

Handling cost in respect of sub-item 8.3.5. A percentage of the payment made to the Occupational Health and Safety Act will be paid to the contractor under this section. The rate shall cover the Contractor's overheads, changes, and profit on payments for the Occupational Health and Safety Act.

- **Provision of Safety Officer**

The Contractor should appoint the safety officer who will be fulltime responsible for all safety issues on site, and he or she should be fulltime on site.

The tendered rates include the full compensation for that part of the provision of safety officer in terms of the Occupational Health and Safety Act and the Construction Regulation which are mainly a function of time. Payment shall be made monthly.

- Handling cost in respect of sub-item 8.3.5.2 (a). A per percentage of the payment made to the Safety Officer will be paid to the Contractor. The rate shall cover the Contractor's overheads, changes and profit on payments for the Safety Officer.

**PS A B.8.3.5.3 Contractor's time related obligation in respect of the OH & S Act and Construction Regulation**

The tendered lump sum shall represent full compensation for that part of the contractor's general obligations in terms of Occupational Health and Safety Act and the Construction Regulations which are mainly a function of time. The lump sum will be paid monthly only after payment for item 1.3.3 and item 1.1.5 has been made. Payment of the lumpsum shall be made monthly (calculated by the division of the lumpsum by the number of months remaining).

**PS A 8.4 SCHEDULED TIME RELATED ITEMS**

**PS A 8.4.2.1 Facilities for Engineer**

- |                                       |             |
|---------------------------------------|-------------|
| a) Engineers office (No)              | Unit: Month |
| b) Communication Costs (No)           | Unit: Month |
| c) Nameboards (No)                    | Unit: Month |
| d) Provision of survey equipment (No) | Unit: Month |

**PS A 8.4.2.2 Facilities for Contractor**

The sum shall cover the Contractor's initial costs of providing sureties, insurance of the works and plant, third party or public liability insurance and unemployment insurance to cover his compliance with the requirements of the Workmen's Compensation Act, 1941 (Act No. 30 of 1941) and any other initial financing obligations of a general and preliminary nature, such contributions to the CEITB. Establishment of Facilities on the Site Facilities for Engineer.

**PS A 8.4.3 Supervision for Duration of Construction**

The sum shall cover the costs of on-site supervision and such local administration as the Contractor considers necessary for the proper completion of the Works, and shall cover the cost of the salaries, wages and allowances paid to the site agent, general foreman, section foreman (where applicable), site surveyors, timekeepers, assistants and other site supervisory staff, and of transport incurred in connection with such staff. Plant (designated plant or plant for designated operations or plant for use during Supervision for Duration of Construction)

**PS 8.4.4. Company and Head Office Overhead Costs for the Duration of the Contract .....Unit: Sum**

The sum shall cover the contractor's company and head office overhead costs.

**PS A 8.5 Sums Stated Provisionally By Engineer**

**PS A 8.5. (a) 1 Community Liaison Officer Unit: Sum**

The Contractor must pay a salary to a person appointed as the Community Liaison Officer for the project. The amount of payment and payment dates will be determined as soon as the Community Liaison Officer is appointed.

**PSA 8.5(a) 2 PSC Meetings Attendance Unit: Sum**

The tendered rate shall cover the compensation of all members of Project Steering Committee for attending meetings. The amount of payment and payment dates will be determined on the commencement date of the project. The Engineer should authorize payment before it is made. Proof of payment has to be submitted to the Engineer before claim can be certified.

**PS A 8.5(a) 3 Overheads, Charges and Profit on (1) above 1%**

Handling costs and profit in respect of sub-item 8.5 (a) 1 & 2. A percentage made to the Community Liaison Officer and PSC Meeting attendance will be paid to the contractor. The rate shall cover the Contractor's overheads, charges and profit on payments for the Community Liaison Officer and PSC members.

**PS A 8.5(b) 1 Training**

Provisional sum for training services supplied by the Training Company. The name and contact details of the Training Company, to be appointed by the Contractor, will be supplied to the Contractor by the Employer or Engineer.

**PS A 8.5(b) 2 Overheads, charges and profit on (1) above**

Handling costs and profit in respect of sub-item 8.5 (b) 1. A percentage of the payment to the Training Company will be paid to the Contractor. The rate shall cover the Contractor's overheads, changes, and profit on payments for the Training Company. No payment will be made under this item before any payment is made to the Training Company.

**PS C 8.5 Existing Services**

The services parallel to the pipeline routes must only be removed and re-erected at the positions as indicated and approved by the Engineer and repaired where it was damaged. When the pipeline routes across the fencing or gates temporary wire gates must be provided that must be kept closed. After completion of the work these fences or gates must be repaired to the same condition as before commencement of the work.

**PS A 8.5(c)2 Overheads, charges and profit from (1) above**  
%

**Unit:**

Handling cost in respect of sub-item 8.5 (c) 1. A percentage of the payment made to the service provider will be paid to the Contractor. The rate shall cover the contractor's overheads, changes, and profit on payments for the Service Provider.

**PS A 8.7 Daywork**

Replace A 8.7 with the following:

Daywork will be paid according to the percentage allowance method. For calculating the total remuneration, the General Conditions of Contract for Construction Works, Third Edition, 2015 shall apply, with the amendments as in the appropriate special conditions of contract, which is bound into this document. A daywork schedule will be provided for filling in the necessary information.

**PROJECT SPECIFICATION: PORTION 2**

**SABS 1200 PSC: SITE CLEARANCE**

**PS C 3 MATERIALS**

**PS C 3.1 Disposal of Material**

Substitute the first sentence of C 3.1 with the following:

Material obtained from clearing and grubbing shall be disposed of at the site indicated at the site inspection. If such a site is indicated at the tender stage, the cost of transporting material and debris will be included under 8.2.1.

Loading and off-loading should be done by hand and the contractor must price accordingly under item 8.2.1.

**PS C 5 CONSTRUCTION**

**PS C 5.1 Areas to be cleared and grubbed**

Substitute the first sentence of C 5.1 with the following:

Unless otherwise indicated by the Engineer, clearing and grubbing are limited to a 2,0m wide strip along the pipe route. Measurement and payment for clearing and grubbing shall only occur for areas as required in writing by the Engineer.

The Contractor may proceed with clearing and grubbing after the handing over of the site.

**PS C 5.2 Cutting Of Trees**

**PS C 5.2.3 Preservation of Trees**

**PS C 5.2.3.2 Individual Trees**

Add the following to C 5.2.3.2:

Trees outside pipeline routes must be left standing and undamaged, except where otherwise ordered in writing by the Engineer.

A penalty of **R15 000,00** per tree for trees damaged and/or removed will be charged.

**PS C 5.9 Existing fencing**

The fencing parallel to the pipeline routes must only be removed and re-erected at the positions as indicated and approved by the Engineer and repaired where it was damaged. When the pipeline routes cross fencing or gates temporary wire gates must be provided that must be kept closed. After completion of the work these fences or gates must be repaired to the same condition as before commencement of work.

**PS C 8 MEASUREMENT AND PAYMENT**

**PS C 8.2 Scheduled Items**

**PS C 8.2.1 Clear and grub (1.0m wide) Unit: m**

The removal of all rocks and boulders on site over 0.15 m<sup>3</sup> will be paid under sub-clause D 8.3.2 (b).  
The removal of hard rocks other than boulders will be paid under the sub-clause PS DB 8.3.2 (b).

**PS C 8.2.2 Remove and grub large tree stumps of girth**

- Over 1m and up to and including 2m .....Unit: No.
- Over 2m and up to and including 3m .....Unit: No.

The girth of a tree or stump will be measured at the narrowest point of the tree or stump in the first meter of its height above ground level. Trees and stumps of girth exceeding 1m will be measured individually and classified according to site in increments of 1m as indicated above.

The rate shall cover the cost of clearing and grubbing trees and stumps of all sizes, cutting branches, backfilling holes, and removing, transporting, and disposing of all such trees, stumps, and branches and associated material.

**PS 8.2.3 Remove and grub all trees and tree stumps regardless of girth..... Unit: No**

In exceptional circumstances, where construction is carried out through plantations or where the quantity of trees or girth exceeding 1m renders individual measurement impracticable the Project Specification may provide that clearing and grubbing of trees be measured in hectares. If this method of measurement is used the areas to which it is applicable will be defined clearly on the drawings and the reason for adopting the method of measurement will be stated in the project specification.

The rate shall cover the cost of all operations specified in 8.2.2.

**PS C 8.2.5 Take down existing fence**

The rate shall cover the cost of taking down the fences, coiling wire and stacking all material at sites indicated by the Engineer and the cost of loading, transporting and offloading such material.

**PROJECT SPECIFICATION: PORTION 2**

**SABS 1200 PSDB: EARTHWORKS (PIPE TRENCHES)**

**PS DB 1 SCOPE**

This specification covers earthworks for trenches for all types and sizes. It covers excavation, the preparation of a trench bottom, backfilling and the reinstatement of surfaces.

**PS DB 3 MATERIALS**

**PS DB 3.1 CLASSIFICATION FOR EXCAVATION PURPOSES**

**PS DB 3.1.1 Method of Classifying**

Substitute DB 3.1.1 and D.B.3.1.2 (a), (b) and (c) with the following:

The Engineer shall classify excavated materials as Soft Class and Rock will be measured individually as extra-over items.

**TABLE 1: CLASSIFICATION OF MATERIALS**

<b>CLASSIFICATION</b>	<b>DESCRIPTION</b>
Soft	All material other than rock
Rock	Material which cannot be economically fragmented and loosened for removal by hand implements and pneumatic tools, except by drilling and blasting or the use of rock breaking equipment.

In the first instance, the classification shall be based on the descriptions given in Table 1. In the event of disagreement between the Contractor and the Engineer, the Engineer shall reclassify the material in accordance with the relevant specifications and without being unreasonable to the Contractor. The decision of the Engineer on the classification shall then, subject to the provisions of the contract, be final and binding.

The Contractor shall notify the Engineer of the presence of what he considers to be rock immediately upon discovery thereof. The Engineer will inspect the material and decide whether or not it warrants the use of pneumatic tools or rock breaking equipment. In the case of isolated boulders set in a soil matrix, the Engineer may order the Contractor to either widen the excavation or roll the boulders sideways or lift the boulders out of the trenches.

In the event that the Engineer decides that the use of pneumatic tools, rock breaking equipment, or blasting is necessary, he will classify the material accordingly and arrange for the quantity thereof to be measured. The Construction Manager will supply necessary pneumatic equipment and arrange for others to break up rock into manageable pieces.

**PS DB 3.5 BACKFILL MATERIALS**

- Substitute "from trenches" in DB 3.5(a) with "from trenches and street excavations".

Add the following to DB 3.5 (b)

- Road crossings, access to services, farms and camps and any section that fall within the road reserve shall be classified as areas subject to loads from road traffic and must be compacted accordingly to the top of the trench (natural ground level).

**PS DB 3.7 SELECTION OF MATERIAL FOR REPAIR WORK**

If the excavation of a pipeline damages an existing road surface, the Contractor must stockpile material from the top 200mm of such a road surface in order to reuse it as sub base for the repairing of the road crossing.

If necessary gravel material that is suitable for the reparation of road surfaces must be imported.

The Contractor must make provision in his tariffs for compaction in road reserves for the selection of excavation material as specified above.

**PS DB 4 PLANT**

**PS DB 4.1 EXCAVATION EQUIPMENT**

Add the following to DB 4.1

An adequate number of suitable tools, including hand stampers, wheelbarrows and hosepipes shall be provided by the Contractor. The Contractor will supply mechanical compaction equipment and when required pneumatic and rock breaking equipment.

All excavations exceeding the specified widths shall be backfilled with approved selected material. No payment shall be made for this and all relevant costs shall be deemed to be included in the tendered rates.

**PS DB 5 CONSTRUCTION**

**PS DB 5.1 PRECAUTIONS**

**PS DB 5.1.1.1 Water in Trenches**

Water in pipe trenches may cause movement of the pipes as a result of floatation and backfilling must therefore be executed as quickly as possible. If movement of the pipes does occur the contractor must, unless otherwise instructed by the Engineer, remove pipes from the trench and reinstall it at his own expense.

**PS DB 5.4 EXCAVATION**

Add the following to DB 5.4:

“Excavation and backfilling of pipe trenches on sidewalks in the residential area shall be done in such a manner as to ensure the least possible disruption to the public and access to the properties. No additional payment shall be made for this and all relevant costs shall be deemed to be included in the tendered rates.”

**PS 5.5 TRENCH BOTTOM**

Substitute “90%” in the second paragraph of DB 5.5 with “93%”.

**PS DB 5.5.1 Over Excavation of Trenches**

Where pipe trenches are excavated deeper than specified or shown on the drawings, these excavations must be backfilled with suitable approved material in layers of not more than 150mm uncompacted thickness and must be compacted to the thickness of the adjoining in-situ material or as prescribed by the Engineer.

**PS DB 5.6 BACKFILLING**

**PS DB 5.6.1 General**

Backfilling in road reserves must be compacted in 100mm layers up to natural ground level. Where prescribed by the Engineer all surplus material must be neatly piled over the real trench width to a height not more than 150mm high than the adjoining level.

**PS DB 5.6.3 Disposal of Soft Excavation Material**

Add the following to DB 5.6.3:

All surplus and unsuitable material as described in DB 5.6.3 shall be disposed of at the spoil site, (as described in PS D 5.2.2.3) and levelled.

**PS DB 5.7 COMPACTION**

**PS DB 5.7.2 Areas Subject to Traffic Loads**

Add the following to DB 5.7.2:

All pipe trenches within road crossings, accesses to services, farms and camps that fall within the road reserve, will be regarded as areas subject to traffic loads. Backfilling of trenches that are subject to traffic loads will be executed in layers of 100mm as follows:

Item	% mod AASHTO	Final Layer Thickness
Approved Backfill	93%	200mm
Main Backfill up to road layers	96%	200mm
Sub-base	97%	200mm
Base	98%	175mm

**PS DB 5.9 REINSTATEMENT OF SURFACE**

**PS DB 5.9.2 Private Property and Commonage**

Add the following to DB 5.9.2:

Gardens and lawns shall be repaired to the original standard where they were crossed. Grass and plants shall be taken out of the ground, temporarily stocked, watered during construction and replanted after backfilling.

**PS DB 8 MEASUREMENT AND PAYMENT**

**PS DB 8.2 COMPUTATION OF QUANTITIES**

**PS DB 8.2.4 Shoring**

Add the following to DB 8.2.4:

Shoring will only be measured and paid for, if the Engineer gives written approval before it is installed.

**PS DB 8.3.2 Excavation**

- Excavation in all material for trenches, backfill, compact and dispose of surplus material ..... Unit: (m)



Item will be provided for various pipe diameters in steps not greater than those specified in 5.2. and various depths in increments of 1.0m measured to the bottom of the bedding layer (see Drawing DB 2, DB 3 and DB 4). Where measured volumetrically in terms of 8.1.2 (a), the volume of excavation will be computed in accordance with 8.2.2 and 8.2.3.

The rate shall cover the cost of the same operation in heading where the Contractor elects to use such a method of excavation. The volume or length will be measured for payment on the assumption that normal trench excavation has been carried out. The volume or length in the undisturbed prism of material between the top of the tunnel and ground level will be classified as soft excavation in terms of 3.1. No additional payment will be made for such headings and no deductions will be made for reduced excavation quantities.

- **Extra-over item (a) above for:**

- Intermediate excavation .....Unit: m<sup>3</sup>
- Hard rock excavation ..... Unit: m<sup>3</sup>
- Hand excavation and backfill where added by the Engineer ..... Unit: m<sup>3</sup>
- Soil Crete backfilling where directed by the Engineer ..... Unit: m<sup>3</sup>

Separate items will not be provided for depth increment, volume will be computed from the trench width determined in accordance with 8.2.3 and the depth from the top of the intermediate or hard rock excavation, as the case may be, either to the bottom of the same material or to the bottom of the trench as specified in (a) above, whichever is the lesser (see Drawing DB 5).

The rates shall cover the additional cost of the excavation and hauling of the more difficult material of unsuitable material.

- Excavate and dispose of unsuitable material from trench bottom (provisional) .....Unit: m<sup>3</sup>

The volume will be computed from the trench width determined in accordance with 8.2.3 and m<sup>3</sup> the additional depth ordered.

The rate shall cover the cost of the excavation of the additional depth in any material, the disposal of the unsuitable material as specified for soft excavation in 5.6.3 within freehaul distance and the backfilling of the additional depth with suitable material from the site of the trench.

### **PS DB 8.3.3 EXCAVATION ANCILLARIES**

#### **PS DB 8.3.3.1 Make up deficiency in backfill material**

- From other necessary excavations on site .....Unit: m<sup>3</sup>
- By importation from designated borrow-pits ..... Unit: m<sup>3</sup>
- By importation from commercial or off-site sources selected by the Contractor .....Unit: m<sup>3</sup>

Items (b) and (c) above will not be measured for payment unless importation has been ordered in writing. The volume will be computed from the trench width determined in accordance with 8.2.3 and the depth from the top of the backfill to the top of the bedding as shown on Drawing DB-1 or the actual depth of the backfill used to make up the deficiency or the depth of additional excavation in terms of B3.2(c), as applicable.

The rate for material from other necessary excavations on site shall cover the cost of selection of suitable material, the moving of the material to points alongside the trench spaced to suit the contractor's method of working, and the disposal of the material that is replaced, all within freehaul distance.

The rate of material from commercial or off-site sources selected by the Contractor shall cover the cost of the acquisition of the material (including royalties, if applicable), the moving of the material to points alongside the trench spaced to suit the Contractor's methods of working, and the disposal of the material that becomes surplus as a result of the importation, all within freehaul distance (see Sub-clause 5.2.5.1 of SABS 1200 D or Sub-clause 5.2.6.1 of SABS 1200 DA, as applicable).

**PS DB 8.3.3.2 Opening up and closing down of designated borrow pit ..... Unit: Sum**

This item will only be scheduled when a new borrow-pit has been established or when access to any existing borrow-pit has to be established.

With the exception of the cost of the removal and spreading back of the topsoil (if scheduled), the sum shall cover the cost of opening up and of restoring the Site as specified in Schedule 5.2.2.2 of SABS 1200 D or Subclause 5.2.2 (f) of SABS 1200 DA, as applicable.

**PS DB 8.3.5 Existing Services**

Existing services – that intersect or adjoin a Pipe Trench (see Sub-clauses 5.1.2 and 8.3.8 of SABS 1200 D or Sub-clauses 5.1.3 and 8.3.5 of SABS 1200 DA, as applicable).

- Services that intersect a trench (angles between centerlines in plan of 45-90°) ... Unit (No)

Except where water pipes are to be recovered, existing water pipes, sewers, stormwater pipes, concrete-lined channels and drains, box culverts, electric cables, ducts, kerbs, channels, erf connections and various sizes of pipes and services that intersect a trench of specified width and require various degrees of care, whether or not their presence is known before they are uncovered, will be measured separately. The unit refers to one service, but services that are so grouped that they can be contained within a horizontal dimension of 200mm measured at right angles to the axis of the services will be measured as one unit.

- Services that adjoin a trench (parallel to or at an angle between center-lines in a plan of less than 45°) ..... Unit: No.

In case where a trench of specified width

Runs parallel to or at an angle (in plan) of less than 45° to an existing service, and is such that the nearer side of the bottom of the trench lies at least partly between the vertical plane and a plane that lies at an angle of 45° below the horizontal, both planes passing through the axis of the service, the length of the service within the minimum base width of the trench, determined in accordance with 5.2, will be measured for payment under this item and the remaining length, the side of the trench which, in the opinion of the Engineer, is rendered liable to collapse because of the existence of such service, will be measured for shoring (see 8.3.4 (a)). The rate for an item scheduled in terms of (a) and (b) above shall cover the additional cost of

1. Care in excavation necessitated by the presence of such service in or across the trench
2. Protection and maintaining such service in operation by means of temporary supports or shoring, as necessary.
3. Repairs necessitated by damage caused by the Contract.

**PS DB 8.3.6 Finishing**

**PS DB 8.3.6.1 Reinstatement road surfaces complete with all courses  
m2**

**Unit:**

Replace D.B 8.3.6.1 with the following:

- Gravel Unit: m<sup>2</sup>

The area will be calculated from the length of finished road and paved surfaces as applicable and with the trench width taken as 0.8m. Payment for finishing will be additional to that for excavation covered by 8.3.2.

The rate shall cover the cost, selective excavation (including the equipment that is required to break up, removed and, if necessary, stockpile the original surface material), and subsequently of reinstating and compaction and shall include the cost of delays and the cost of any risk of having to repair damage as specified in DB 5.10. Compaction to be according to PS DB 5.7.2.

**PROJECT SPECIFICATION: PORTION 2**

**SABS 1200 PS LB: BEDDING (PIPES)**

**PSLB 1 SCOPE**

This specification covers the bedding (bedding cradle and selected fill blanket) for buried pipes carrying fluids under pressure or gravity. It covers the basic materials, the quality, manufacture, tolerances in workmanship, testing and the methods by which the finished structure is to be measured for the purposes of the payment.

**PSLB 3 MATERIAL**

**PSLB 3.1 Selected granular material**

Selected Granular Materials (sub clause 3.1)  
Delete the word "singularly"

**PSLB 3.3 Bedding**

Add the following to LB 3.3:

All pipes shall be classified as flexible pipes and shall be laid on a Class C bedding except at stream and road crossings, which shall be classified as rigid pipes.

**PSLB 3.4 Selection**

Suitable selected bedding material will occasionally be available from trench excavations along the route.

**PSLB 5 CONSTRUCTION**

**PSLB 5.1 Trench**

**PSLB 5.1.4 Compacting**

Substitute "90 % of mod AASHTO" in LB 5.1.4 with "93 % of mod AASHTO (100 % for sand)". The use of mechanical compaction equipment will not be permitted within 300mm above the crown of the pipe

**PSLB 6 TOLERANCES**

**PSLB 6.1 Moisture Content and Density**

The degree of accuracy shall be II.

**PS LB 8 MEASUREMENT AND PAYMENT**

**PS LB 8.2 Scheduled Items**

PS LB 8.2.2.4 From stockpile (provisional)

- a) Selected granular material ..... Unit: m<sup>3</sup>
- b) Selected fill material ..... Unit: m<sup>3</sup>

The rate shall cover the cost of obtaining, handling and transport regardless the distance, of the required bedding material from the stockpile, the delivery thereof at positions that are spaced along the trench in such a way as suits the working method of the Contractor, as well as the removal of material displaced by this importation within the free-haul distance.

## PROJECT SPECIFICATION: PORTION 2

### SABS 1200 PSGA: CONCRETE (SMALL WORKS)

#### PSG1 SCOPE

This specification covers the requirements for concrete (plain and reinforced) for small works associated with pipelines, roads, railways, pump stations, etc. It covers the basic materials, the plant formwork required, the quality, manufacture, and curing of concrete, tolerances in workmanship, testing and the methods by which the finished structure is to be measured for the purposes of the payment.

#### PSGA 3 MATERIAL

##### PSGA 3.2.1 Applicable Specifications

Add the following to G 3.2.1:

Portland cement that conforms to SABS 471

##### PSGA 3.2.2. Storage of Cement

Add the following to G 3.2.2:

Consignments of cement shall be used in the same sequence as that in which they are delivered on site. No cement shall be used which has been stored on site for a longer period than 6 (six) weeks. All cement so stored for a longer period than 6 (six) weeks, all cement damaged in any way, and all cement which does not comply with the specification, shall be removed immediately and permanently from the site.

#### PSGA 4. PLANT

##### PSGA4.4 Formwork

##### PSGA 4.3.3 Ties

Add the following to G 4.4.3:

No ties will be allowed in vertical walls and permanent metal ties shall have a minimum concrete cover of 40mm. Tie holes shall be filled with an approved non-shrink epoxy grout.

#### PSAGA 5 CONSTRUCTION

##### PSGA 5.1 REINFORCEMENT

##### PSGA 5.1.3 Cover

Substitute G 5.1.3 with the following:

The cover of concrete over reinforcement, unless otherwise indicated on the drawings, shall be not less than 40mm.

##### PSGA 5.2 FORMWORK

##### PSGA 5.2.1 Classification of Finishes

Add the following to G 5.2.1:

The following surface conditions are required in the various portions of the finished concrete:

- Rough

Concealed surfaces and surfaces lower than 100mm below finished ground level.

- Smooth

All surface finishes not classified as “rough” in paragraph (a) shall be classified as “smooth”. All exposed edges otherwise indicated on the drawings, shall be chamfered 20 mm x 20 mm by means of triangular fillets fixed to the formwork.

#### **PSGA 5.4 CONCRETE**

##### **PSGA 5.4.1 Quality**

##### **PSGA 5.4.1.2 Consistency**

Add the following to sub clause G 5.4.1.2:

The slump of concrete used in water retaining structures may not be less than 30mm and not more than 60mm.

##### **PSGA 5.4.1.5 Strength of Concrete**

Add the following to G 5.4.1.5:

The grade of strength of concrete and the maximum normal size of coarse aggregate for each portion of the works, unless otherwise indicated on the drawings, shall be as follows:

- |   |             |
|---|-------------|
| • Blinding layers and encasing of pipes | 20 MPa/19mm |
| • Benching                              | 20 MPa/19mm |
| • Screeds                               | 20 MPa/10mm |
| • Reinforced concrete                   | 35 MPa/19mm |

##### **PSGA 5.4.1.7 Durability**

Concrete shall be so proportioned to ensure that the water/cement ratio does not exceed 0,5 and, to ensure workability, water-reducing admixtures of approved manufacture shall be used in preference to increase the cement content.

##### **PSGA 5.4.8 Concrete Surfaces**

Add the following to GA 5.4.8.1:

Concrete surfaces under screeds, granolithic finishes or benching shall be brought up to a plane, uniform surface with a suitable screed board.

##### **PSGA 5.4.11 Construction Joints**

The use of construction joints must be minimized and may only be placed as shown on the drawings or at positions as approved by the Engineer.

At all construction joints in walls a HDPE water stop without a center bulb must be placed as shown on the drawings.

Alternative materials with similar properties may be proposed but may only be installed after approval of the Engineer.

#### **PSGA 5.4.12 Wood-floated finish**

Where wood-floating is specified or scheduled, the surface shall first be given a finish as specified in G 5.5.10.1 and after the concrete has hardened sufficiently, it shall be floated to a uniform surface free from trowel marks. The screed surface shall be wood-floated, either by machine or hand, only sufficiently to produce a surface free from screed marks.

#### **PSGA 5.5.4.13 Steel-floated finish**

Where steel floating is specified or scheduled, the surface shall be treated as specified in PS G 5.5.10.4 except that, when the moisture film has disappeared and the concrete has hardened sufficiently to prevent laitance from being worked to the surface, the screed surface shall be steel-troweled under the firm pressure to produce a dense, smooth, uniform surface free from trowel marks.

### **PSGA 8 Measurement and Payment**

#### **PSGA 8.1.1 Formwork**

Formwork, other than formwork covered by 8.1.1.2 and 8.1.4, will be measured as the net area of the face of the concrete to be supported during the disposition of concrete. No deduction will be made for fillets and splays of size up to 50mm x 50mm or for openings of diameter up to 0,7 m or of area up to 0,5 m<sup>2</sup>.

Formwork in continuous lengths of narrow widths and of filters or splays over 20 mm x 20 mm will be measured by length, the width or range of widths being stated in the schedule. Boxing-out, the forming of holes, and other such operations will be measured by number, basic dimensions, perimeters, or drawing references, as stated in the schedule.

The unit rate shall cover the cost of all parts of formwork in contact with the concrete, and the necessary bearers, struts, and other supports, plus the labour and plant necessary to erect and stick such formwork.

#### **PSGA 8.1.2 Reinforcement**

Steel for normal reinforced concrete will be measured net by mass of all bars, including supporting steel detailed on the reinforcing schedules. The mass will be computed from the nominal bar size and nominal mass per unit length. No allowance will be made for cutting, waste, spacer devices (material other than steel bars), or binding wire.

Steel reinforcement for precast concrete units will not be measured unless so scheduled (see 8.6).

Welded mesh will be measured by area as shown on the drawings, no allowance being made for cutting, waste, laps or deductions for end cover. The areas measured will be those of the concrete floor or slab being reinforced by means of mesh. In the case of continuous unit partly reinforced by mesh, the area will be computed from the outside dimensions of the area covered by mesh regardless of whether or not additional reinforcing shall is present in the same area.

Steel off cuts resulting from the cutting and bending of reinforcement in accordance with the bending schedules shall be deemed to be the property of the Contractor.



**PSGA 8.1.3 Concrete**

- Concrete will be measured net to the dimensions **shown on the drawings** or to the dimensions cast, whichever are the smaller. Structural elements that are undersized will be measured for payment only if they are accepted by the Engineer.
- No allowance will be made for concrete required to make up overbreak in soft excavation, but payment will be made for additional concrete or formwork, or both, ordered in writing by the Engineer to replace unsuitable material or overbreak in hard rock or in intermediate excavation (see (d) below).

The unit rates shall cover the cost of the provision of concrete (made with ordinary Portland cement unless otherwise scheduled), mixing, testing, placing, compacting, the forming of stop-ends and unforeseen construction joints, striking of for levelling as applicable, and curing and repairing where necessary, together with the cost of all parts of formwork in contact with the concrete and the necessary bearers, struts, and other supports, plus layout and plant necessary to erect and strike such formwork.

**PROJECT SPECIFICATION: PORTION 2**

**PSG CONCRETE (STRUCTURAL) (SANS 1200 G)**

**PSG2 Interpretations**

**PSG2.4.2 Strength concrete**

Unless otherwise specified on the drawings or in the Schedule of Quantities, all structural concrete shall be Grade 35MPa/19mm.

**PSG2.4.3 Joints**

Notwithstanding Subclause 2.4.3, "designated joints" will only be joints that are shown on the drawings. Any other joints that are required by the Contractor as a result of his construction constraints or for any other reason, whether approved by the Engineer or not, will not be considered to be designated joints as defined in Subclause 2.4.3, i.e. they will be considered to be "non-designated" joints.

**PSG3 Materials**

**PSG3.2.1 Cement**

Replace G 3.2.1 with the following:

All concrete mix designs shall be approved by the Engineer in advance. Strength of concrete is as shown on the drawings.

The mix design and casting procedure shall be approved by the Engineer prior to casting.

Portland Cement I5FA ("PC I5FA") compliant with the requirements of SANS 831 can be used. The fly-ash cement obtained by blending of the OPC and Pulverised Fly Ash (PFA) shall comply with the requirements of SANS 1466-1988. No other types of cement (e.g. Rapid Hardening Cement, Portland Blast furnace Cement) may be used. If aggregates to be used in this contract are alkali-reactive, the OPC used on this Contract shall not have an alkali content  $(Na_2O + 0,656K_2O)$  which exceeds 0.6% by mass of the cement. For the cement used in conjunction with the selected additional aggregates the alkali content per cubic metre of concrete shall not exceed 2,1kg. The Contractor shall submit the necessary test results to prove the above.

Add the following to G 3.2.1:

"In accordance with the new SANS, all Portland cement (OPC or RH) shall be in accordance with SANSENV 197-1 (CEM II) except for non-structural concrete where CEM I 32.5 is acceptable. Pulverized fly ash (PFA) shall conform to the requirements of SANS1491-2."

**PSG3.2.2 Alternative types of Cement**

Replace the contents of G 3.2.2 with the following:

"Only ordinary Portland cement (OPC) may be used. Should the Contractor wish to use any other type of cement, he shall obtain the Engineer's prior written approval (see G 8.1.3.2 and 8.1.3.3)."

**PSG3.2.3 Storage**

Cement shall be used in the order in which it is received.

Unless approved by the Engineer, cement kept in storage for longer than 10 weeks shall not be used in the Works.

Any cement that contains lumps that cannot easily be crumbled to powder between the fingers, may not be used.

**PSG3.3 Water**

Only potable quality water from an approved source may be used for mixing concrete. Water from a river or stream may however be used for curing.

**PSG3.4.1 Aggregates**

The maximum aggregate size shall be as shown on the drawings.

Aggregates may be obtained from local sources subject to testing of its suitability by an approved laboratory and approval by the Engineer.

The maximum water absorption of the coarse aggregate shall not exceed 1% and the flakiness index shall not exceed 25%. The maximum water demand of the fine aggregate shall be 190 l/m<sup>3</sup> and the aggregate shall comply with the requirements of SANS1083.

Aggregates to be used in this contract shall be tested in accordance with subsection C-15 of SANS 1083 to determine whether they are potentially alkali-reactive. If they are alkali-reactive they shall either be replaced with aggregates that are non-reactive. The fineness modulus of the sand must be between 1,7 and 2,8 with a standard deviation of not more than 0,1. 19 mm aggregate size (maximum 20 mm to be used).

At tender stage the Contractor shall assure himself by means of tests and test mixes by an accredited laboratory that the fine and coarse aggregates that he intends to use comply with the specification. The tendered rates shall therefore be deemed to allow for the importation of aggregates that do comply with the Specification.

The Contractor shall be responsible for locating the sources of all aggregates.”

Aggregates shall be tested periodically for reactivity, the cost of which shall be deemed included in the rate tendered for concrete. A design mix will have to be made and the results submitted to the Engineer for approval 14days prior to casting the first concrete.

*Add the following new sub-clause to G 3.4:*

**PS G3.4.4 Alkali-aggregate Reaction**

The quartzite and shale of the Witwatersrand Supergroup contains have secondary materials such as silica and calcite believed to be responsible for moderate level of potential alkali reaction reported in reservoirs, bridges. This shall not be used in conjunction with high alkali cement in concrete in any part of the Works. For the purposes of this clause, a high alkali cement is one in which the equivalent alkali content ( $\text{Na}_2\text{O} + 0.658 \text{K}_2\text{O}$ ) exceeds 0.60 % by mass of the cement.

In order to ensure that the above requirement is met, the Contractor may elect to use an aggregate other than Witwatersrand Supergroup that complies with the requirements of SANS1083. Alternatively, if the Contractor chooses to use Witwatersrand Supergroup, he shall comply with the following requirements regarding the cement:

- a) Before commencing any particular section of the structure, the Contractor shall ensure that he has enough cement that is not a high alkali cement to complete the section.
- b) Certificates stating the alkali content of each delivery of cement to the Site shall be supplied by the Contractor. These certificates shall be based on tests carried out at a laboratory approved by the Engineer. The cost of testing, including sampling, transporting of samples, and issuing of certificates, shall be borne by the Contractor.
- c) The Contractor shall be entitled to use an approved brand of cement as a means for ensuring that the permissible alkali content is not exceeded. The Contractor shall make allowance for the higher price of such approved brand, if he chooses to use this method.
- d) High alkali cement delivered to the Site shall be rejected, and the cost of its removal and replacement with cement with acceptable alkali content shall be borne by the Contractor.”

#### **PSG3.4.5 Samples**

At least one month before commencement of concrete work the Contractor shall supply at his own cost representative samples to the Engineer of the aggregates he intends using, together with certificates from an approved laboratory indicating that the aggregates comply with the specifications. Approximately 50 kg of each sample of aggregate shall be supplied.

#### **PSG3.5 Admixtures**

The use of admixtures will be subject to the approval of the Engineer. The information listed in Subclause 3.5.1 shall be provided.

In addition all water retaining structures will include admixture as specified.

Add the following new sub-clause to G 3:

#### **PSG3.9 Materials for movement joints**

##### **PSG3.9.1 General**

The various jointing materials, the manufacturers of the materials and the methods of application shall be as approved by the Engineer. Materials shall be stored and protected to avoid damage, degradation, distortion or contamination.

The joint materials shall be resistant to ultraviolet light and to biological degradation.

##### **PSG3.9.2 Waterstops**

Waterstops shall be of approved manufacture and of the pattern and the material and widths scheduled and specified and shown on the drawings. They shall comply with the tolerances specified in Subclause 6.1. They shall conform to Specifications CKS 388 or 389, for natural rubber or PVC respectively.

All intersections between waterstops shall be prepared by mitring and welding/vulcanising intersection pieces in the factory in accordance with the manufacturer's instructions and to approval of the Engineer. Only straight lengths of waterstop may be field welded using the appropriate jigs and tools.

Where required, waterstops shall have eyelets so that they may be tied securely to the adjacent reinforcement. "Rearguard"-type waterstops shall have flanges or cleats that grip effectively.

**PSG3.9.3          Fillers**

Closed cell expanded polyethylene fillers shall be precut to suit the application with a tear-out strip for forming the specified recess for the sealant. If so required the filler shall be glued into position with an approved epoxy glue.

**PSG3.9.4          Bond breakers, primers and sealants**

The bond breaker (if specified) shall be self-adhesive PVC tape (or equal, approved material) with a width the same as the joint recess into which it is to be applied.

The primer, if required for the sealant, shall be fully compatible with the sealing compound that is to be used.

The elastomeric sealant shall be either a two-component polysulphide liquid polymer base complying with the requirements of SABS 110 or a polyethylene based polyurethane "pouring grade" for horizontal or near horizontal joints or "gun grade" for vertical/overhead joints and joints steeper than 1 in 10 to the horizontal. All elastomeric sealants shall comply with BS 4254 Type A1 and shall have a movement tolerance of 25%.

**PSG4              Plant**

**PSG4.3/4.4        Mixing plant and vibrators**

Stand-by mixers and vibrators of adequate capacity and with an independent power unit shall be maintained on site for immediate use in the event of breakdown of the regular mixers or vibrators or failure of the power supply.

**PSG4.5            Formwork**

**PSG4.5.3         Formwork ties**

The use of sleeves for formwork ties through the walls of water-retaining structures will not be permitted. Ties, when cast in, shall have some form of positive anchorage to prevent any rotation when loosening formwork.

For watertight concrete structures the shutters shall be fastened using an approved imbedded fastening system. Open ferrules will not be permitted in the reservoir.

*Add the following new sub-clause to G 4.5:*

**PSG4.5.4         Formwork: chamfers and fillets**

All exposed external angles in concrete work shall have 20 mm x 20 mm chamfers unless otherwise specified or ordered, but the top edge of a slab that is to receive an applied finish shall not be chamfered.

Internal corners in concrete work need not have fillets unless such fillets have been specified on the drawings or ordered by the Engineer.

**PSG4.5.5 Water-bath**

A temperature-controlled water-bath with a capacity to cure two hundred cubes shall be provided on site. The water-bath shall be located under cover.

**PSG5 Construction**

**PSG5.1 Reinforcement**

**PSG5.1.2 Fixing**

Fixing of reinforcing bars by welding and heating of bars will not be permitted.

**PSG5.1.3 Cover**

In Subclause 5.1.3(a) amend the words "bar or stirrup" to read: "bar, secondary reinforcement, stirrup, tying-wire knots or wire ends".

Tying wire may not encroach on the specified minimum cover by more than a single strand thickness.

*Add the following new sub-clause to G 5.1:*

**PSG5.1.6 Spacers**

Spacers of approved design include approved plastic or other proprietary spacers, or purpose made precast mortar blocks.

Where mortar blocks are used they shall be properly shaped so as not to slip out of position and shall be made of the same mix as the mortar of the concrete in which they are to be placed. The mortar shall be well compacted by approved means into the moulds to result in blocks with a density of at least 2 300 kg/m<sup>3</sup> and which are free from honeycombing. The mortar blocks shall be cured in water for at least 7 days. Blocks which have not been manufactured and cured strictly in accordance with these requirements or which are in any other way considered unsatisfactory by the Engineer, will be rejected and shall be removed from the Site.

**PSG5.2 Formwork**

**PSG5.2.1 Classification of finishes**

Rough formwork Degree of Accuracy III may be used on the outside faces where concrete is more than 500mm below the final ground level.

**PSG5.2.5 Removal of Formwork**

The Contractor shall make provision for the continued support of beams and slabs while the formwork is being removed and/or for back propping of beams, slabs, etc. The propping may be required simultaneously on more than one level directly underneath one another. The requirements for continuous propping and/or back propping shall be calculated to a theoretical model that is acceptable to the Engineer, and details shall be submitted for the Engineer's approval. Data required for such calculations, e.g. design loads and structural dimensions, will be supplied by the Engineer on request.

**PSG5.2.6 Special smooth finish (Additional sub-clause)**

All concrete surfaces that will be exposed above the final ground levels shall have a special smooth finish to a Degree of Accuracy I. The formwork used shall be high-grade, unblemished and regular in size. Formwork ties shall be placed in a regular pattern. The special smooth finish shall be an off-shutter finish to the concrete such that no after treatment is required other than at the positions of formwork ties.

**PSG5.2.7 Construction Loads** (Additional sub-clause)

The contractor shall not impose any construction loads which overstress the shaft walls, allowing for the age of the concrete at the time of loading and the design loads as shown on the drawings. Where necessary, propping shall be carried through more than one pour lift with the props placed as per approved lifting formwork by temporary works designer.

**PSG5.5 Concrete**

**PSG5.5.1.1 General**

The concrete mix design for strength concrete must be prepared in an approved laboratory and the results of actual test mixes must be submitted for approval together with 7-day and 28-day strength test results. Special attention is drawn to the fact that the concrete mix must provide a very dense and impervious concrete.

The concrete shall also be tested for water sorptivity, oxygen permeability, chloride conductivity, depth of cover and shrinkage.

No concrete shall be cast until the mix designs have been approved by the Engineer. The Engineer may call for revised mix designs at any stage during the Contract.

Any mix for use in the wall or floor of a water-retaining structure shall have a water/cement ratio not exceeding 0,5, shall contain not less than 375 kg cement per cubic metre of concrete and the proportions of the various aggregates shall be such as to produce a density of at least 2 400 kg/m<sup>3</sup>. For concrete containing PFA the maximum cement content shall be 450 kg/m<sup>3</sup>.

In order to facilitate increasing the workability of concrete in the fresh/plastic state, to ensure watertightness without increasing the water/cement ratio, the Engineer may approve the use of an additive.

The workability of concrete shall be assessed by means of the slump test. The slump of each batch of concrete shall be taken and recorded directly before casting.

**PSG5.5.1.4 Chloride content**

With reference to Table 4, efflorescence will not be acceptable on any exposed concrete surface.

**PSG5.1.5 Durability**

The exposure conditions for concrete are classified as "Severe".

Add the following values to table 5:

"The maximum water/cement ratio for moderate sections, general water retaining reinforced concrete, exterior portions of mass concrete, as well as for internal concrete in buildings under conditions of moderate exposure, is 0,50.

The maximum water/cement ratio for concrete slabs on the ground under very severe conditions, is 0,45."

**PSG5.5 Concrete**  
**PSG5.5.1.7 Strength concrete**

Unless otherwise specified on the drawings or in the Schedule of Quantities, all structural concrete shall be Grade 35 MPa watertight concrete.

In the design of the concrete mix, special attention must be given to the fact the concrete is to be used in a water retaining structure and should therefore be a very dense mix.”

**PSG5.5.2 Batching**

Batching of strength concrete shall be by mass. Prescribed concrete may be batched by volume.

**PSG5.5.2.2 Water**

“The accuracy of the measurement of water shall be within 2% of that required.

Water for curing concrete shall not contain impurities in sufficient amount to cause discolouration of the concrete or produce etching of the surface.

No water shall be added on site to ready mix concrete prior to placing to improve workability. All concrete delivered to site shall be checked for workability using the slump cone test and slump measured outside of the limit set from the design mix shall be rejected.

Water samples from the intended source of supply shall be taken for analysis before any concrete work is commenced, and at monthly intervals throughout the duration of the contract. If the samples are unacceptable the contractor shall either change a supply or take steps to improve the existing source, as approved.”

**PSG5.5.2.4 Additives (Additional sub-clause)**

Approved additives shall be batched by equipment having a suitable mechanical/electrical interlock device which prevents under or over dosage of the mix.

**PSG5.5.3.2/7.3 Ready-mixed concrete**

Concrete from a central concrete production facility other than on the construction site will be permitted and, apart from test results in terms of 7.3.1, 7.3.2 and/or 7.3.3, test results obtained by such a production facility as part of its quality control system will be accepted for evaluation in terms of Subclause 7.3.4, provided they are stored and cured on site.

**PSG5.5.5 Placing of concrete**

Structural concrete shall not be cast directly against the side of any excavation without the use of formwork unless prior approval has been obtained in writing from the Engineer.

Concrete used in pipe trenches for encasement may be cast directly against the side of the excavation. Concrete for thrust/anchor blocks shall be cast directly against the side of the excavation.

The casting procedure shall be submitted to the Engineer for approval at least 14 days prior to the start of casting.

After vibration, the concrete shall be spaded in corners, in angles and against forms to release air bubbles which may have been trapped in these positions.

**PSG5.5.5.10 Size of Cast (Additional sub-clause)**



“In establishing the size of any one cast the contractor shall give due consideration to, and will be solely responsible for, defects which may arise from drying shrinkage, heat of hydration, or bleeding of the concrete, unless such defects flow from construction procedures stipulated by the Engineer to which the contractor has objected in writing”.

**a) Instrumentation of large concrete pours for foundation footing**

“The contractor is required to model the effects on large members of temperature increases as a result of cement hydration during production and curing of concrete and use measures to prevent thermal cracking”.

For all large concrete pours water tower base and cable anchorage structures, thermocouples shall be installed in the concrete in the centre of the pour and close to the outside surfaces to monitor temperatures during the hydration process. The type, installation method, fixing and location of the thermocouples shall be shown in a method statement which shall be submitted to the engineer 28 days before concreting of the element is proposed. Concrete placing shall not proceed until the approval of the engineer has been given and the suitability of the proposed equipment has been demonstrated by tests. The thermocouples shall be held in position in a robust manner to avoid damage or movement during concreting operations.

Temperatures within the concrete shall be recorded for each thermocouple at regular intervals and sufficient frequency from the time of placing until such time as the temperature difference between the centre and the edges of the pour is clearly established as a falling trend.

The temperature difference between the centre and the edges or between any two thermocouples, unless it can be shown that this difference is not critical to the integrity of the concrete, shall not exceed 22° C. The rate of monitoring can be reduced once it has been demonstrated that the above requirements can be met for all subsequent similar pours. The maximum temperature at any location within the pour shall not exceed 70° C.

Where it is shown from the monitoring that temperatures are excessive or that temperature differences are too high, adequate measures shall be undertaken to reduce these to acceptable levels. To avoid damage to the permanent works concrete being subjected to such unacceptable temperature effects, trials shall be undertaken in advance of permanent works concrete placing to ascertain temperature generation levels likely using the proposed concrete materials storage methods, water cooling, mixing, placing, heat insulation and curing methods”.

**b) Field Trial Mixes**

Add the following

At least 35 days before the commencement of concreting, trial mixes shall be prepared under full-scale site conditions.

Trial mixes shall be made on each of 3 days; the workability shall equate to the designed target value. Six cubes from each mix shall be taken, three for test at 28 days and three for test at 7 days.

Further the trial mixes shall be made if the range (the maximum minus the minimum of the three cube results in any batch) exceeds 15% of the average of that batch, or if the range of the three batch averages exceeds 20% of the overall average of the batches.

The mixes shall be tested to determine the following properties:

- Workability
- Plastic density
- Water/cement ratio
- Bleeding
- Compressive strength at 7 and 28 days
- Hardened density
- Durability

Acceptable values for the limits of these properties shall be established during the trials, which shall be used to monitor the quality control of the mixes and set the standards of compliance.

The average 28-day compressive strength of the three cubes produced for each trial mix shall exceed specified characteristic strength by at least 8 MPa.”

**c) Temperature and Hydration of Concrete**

Add the following

The temperature of concrete delivered to the point of placement shall be within the range 10° C to 30° C. Concrete which has a temperature outside of this range shall not be placed in the structure.

The rate of hydration of the cement in the concrete shall be such that the concrete can be placed and properly compacted within 2 hours after the addition of water to the mix ingredients. The initial set of the concrete shall not be unduly delayed due to inappropriateness of admixtures or cement type, which could promote bleeding.”

**PSG5.5.7 Construction joints**

**PSG5.5.7.1 General**

The edge of joints, exposed to view in the finished structure, shall be formed with suitable beads to provide a straight edge true to line and level.

All joints, other than expansion, contraction and other movement joints, shall be treated as follows:

As soon as practical, but not before 15 hours after placing, the construction joint surface shall be prepared to receive fresh concrete. This preparation, as specified in 5.5.7.3(a) to (d), shall be such as to remove all laitance or inert material which may have formed and the specified chipping or sand blasting shall be such as to produce a roughened surface all over.

When concreting is interrupted concrete surfaces shall be protected from the sun as specified in Subclause 5.5.8(d) or by means of hessian kept damp until concreting is resumed. The Engineer is to be informed immediately when an interruption occurs in the casting of the concrete.

All constructional joints (both designated and non-designated, see PSG2-3), (i.e. all joints other than movement, contraction and expansion joints) shall be dealt with as specified in Subclause 5.5.7.3.

Unless construction joints between designated joints shown on the drawings are authorized by the Engineer in writing, concrete in the floor and wall shall be cast continuously between the designated joints shown on the drawings.

*Add the following to sub-clause G 5.5.7.3:*

d) Construction joints in water retaining structures:

The surface of the concrete shall be brushed with a steel wire brush or chipped with a light hammer or bush hammer or sprayed with a high pressure water jet within 24 hours of casting to remove all laitance and fine particles to a depth of at least 10mm and to expose the coarse aggregate embedded in sound concrete. Whichever method is used to expose the coarse aggregate the Contractor shall ensure that the green concrete is not damaged or disturbed during the preparation of the joint and that water stops are not damaged.

After the reinforcement for the next pour has been fixed and the formwork erected, the construction joint shall be cleaned thoroughly with a pressurised water jet. The joint shall then be wetted continuously with water for 24 hours to completely saturate the concrete immediately before new concrete is cast. Before the new concrete is cast all excess water shall be removed from the construction joint and the new concrete shall be cast directly onto the prepared surface.

**PSG5.5.7.4 Formed joints (Additional sub-clause)**

Each joint shall be formed as shown on the drawings, complete with shear key rebates, waffle formwork, V-feature, waterstops, "Flexcell" or equal, approved joint filler, dowel bars and their PVC tubes, etc. as indicated.

(a) Construction joints in walls

All construction joints in the water retaining walls and footing shall be cast with waterstops. Waterstops shall be 2mm thick HDPE strips. Payment shall be per linear meter. The rate shall include supply and casting in of the waterstop.

(b) Construction joints in roof slabs

Construction joints in the roof slab are permitted. The position of these joints shall be approved by the Engineer. Again, these joints shall be cast against a vertical shutter leaving a 10mm deep x 5mm wide recess which is sealed on both sides with "Sikaflex-11FC" one-part elastic joint sealant (or similar approved) to the Engineers approval.

The payment unit shall be for the linear metre. The tendered rate shall include the supply and casting-in of the water-stop, the sealant and the forming and preparation of concrete at the joint all inclusive.

(c) Construction joints (horizontal) in the walls

Construction joints in the walls are permitted. Allowable positions of these joints are shown on the drawings or shall be to the approval of the Engineer.

The waterproofing bandage shall be applied on both sides with "Sika Combiflex SG20" (or similar approved) to the Engineers approval. "SIKA water bars V20" or similar approved 200mm wide PVC water-stops are required as shown on the on Drawing No. J000096-ST-CO-006. All water-stops shall be heat-weld jointed on site strictly in accordance to the manufacturer's specifications.

The payment unit shall be for the linear metre. The tendered rate shall include supply and casting-in of water-stop, the sealant and the forming and preparation of concrete at the joint all inclusive.

(d) Expansion and contraction joints

Expansion and contraction joints shall be constructed as detailed on drawings using PVC or rubber water stops. Water stops extruded from recycled material shall not be permitted.

Prior to bandaging, concrete surfaces shall be scabbled with a mechanical scabbler and water jetted with a 120 bar water jet. All joints shall be butt jointed and patched over.

The waterproofing bandage shall comprise of two elements:

- (i) A 2 mm thick Hypelon strip (350 mm wide for expansion joints and 250 mm wide for contraction joints)
- (ii) A 1 mm x 60 mm stainless steel strip with polythene backing bond breaker to the detail shown on the drawing.

The bandage shall be applied by coating the concrete and underside of the hypelon bandage with an epoxy adhesive. The stainless steel strip is first positioned over the joint and the bandage with epoxy adhesive placed over the stainless steel strip. All trapped air shall be eliminated by hand rolling the bandage until the epoxy is fully cured.

Payment shall be per linear meter. The rate shall cover all costs for the supply and application of water stops and bandaging including the installation of the stainless steel strip.

Expansion and contraction joints shall be formed true to line in smooth formwork.

All surfaces shall be thoroughly cleaned of all accretions of concrete or other foreign matter by scraping or other approved means.

Particular care shall be taken to compact the concrete around water stops, edges, etc.

**PSG5.5.7.5 Non-designated joints** (Additional sub-clause)

Any non-designated joints shall be identical to designated joints, as shown on the drawings, which would be used in similar positions and perform the same function.

**PSG5.5.7.6 Joints between footings or floors and walls or columns** (Additional sub-clause)

Construction joints between foundations, footings or floors and walls, columns or piers connected to them, shall not be made flush with the supporting surface, but shall be made at a distance above the footing or floor shown as on the drawings or approved by the Engineer. The "kicker" shall be cast as an integral part of the foundation, footing or floor.

**PSG5.5.7.7 Application of primers and adhesives** (Additional sub-clause)

The concrete to which the primer or adhesive is to be applied shall be dry and shall be cleaned of all dust, grit, grease, surface laitance and foreign matter by compressed air and/or water, solvents, or other suitable approved means. The Contractor shall provide on Site an approved moisture meter to measure the degree of dryness of the joint. This meter shall be made available to the Engineer for testing. The joint shall be approved for the application of the primer and adhesive if the moisture content of the concrete is less than or equal to 5%. It may be necessary to dry the concrete surfaces locally by means of a gas torch or other approved manner.

**PSG5.5.7.8 Installation of waterstops in joints** (Additional sub-clause)

Waterstops shall be held in the formwork so as to prevent air pockets forming underneath them. Special precautions shall be taken to the approval of the Engineer, to ensure that all flexible waterstops are in perfect contact with well compacted void-free concrete. The Contractor shall provide satisfactory supervision of such vital operations.

**PSG5.5.7.9 Installation of joint filler in expansion joints** (Additional sub-clause)

Joints in the filler shall be neatly butted so as to exclude mortar from the joint. Edges of filler strip against waterstops, concrete, formwork, projections, etc., shall also be closely fitted to exclude mortar, so that there is no resistance (other than the compression of the filler) to the expansion movement for which the joint is designed.

Joint filler shall be fixed to the first cast of concrete with an approved adhesive and as directed by the Engineer.

**PSG5.5.7.10 Application of joint seals** (Additional sub-clause)

Rebates shall be cleaned as required by PSG5.4.5 and shall be inspected and approved by the Engineer's Representative before filling.

Joint sealants and primers shall be applied strictly in accordance with the manufacturer's instructions. Flow and non-slumping grades shall be used for horizontal and vertical joints respectively.

Only skilled workmen, experienced in this type of work shall be employed to apply the sealant.

Immediately after the compound is applied the joint shall be protected against damage until completion of the Contract.

**PSG5.5.8 Curing and protection**

**a) Base footing and Floor and Slab**

Abovementioned structural elements shall be protected with approved plastic sheets that comply with the requirements as specified below immediately after the prescribed surface finishing has been completed. When the concrete has gained sufficient strength to prevent damage to the surface thereof, the plastic sheets shall be removed on a regular basis to allow the application of more water to the concrete to ensure that it is kept moist continuously. Plastic sheets shall be reinstalled after each wetting of the concrete. The curing period shall be at least 10 days.

**b) Walls**

Structural elements other than horizontal elements, such as walls, shall be thoroughly sprayed with water immediately after the removal of form work. Immediately after this the concrete shall be covered with approved plastic sheets. These shall be removed on a regular basis to allow the application of more water to the concrete to ensure that it is kept moist continuously. Plastic sheets shall be reinstalled after each wetting of the concrete. Abovementioned shall be cured by means of this method for at least 10 days.

Plastic sheets used for curing shall be waterproof and may not be torn or otherwise discontinuous. It shall be white or lightly coloured. Black or other dark coloured plastic sheets shall under no circumstances be allowed. Sheets shall be held down or fixed securely to the elements being cured and joints in sheets shall be taped to prevent loss of moisture from the concrete. Care shall be exercised to prevent staining of exposed concrete.

Notwithstanding the preceding specifications, the Contractor shall also ensure that the concrete shall not be exposed to thermal shocks during the first 28 days after casting and he shall take the necessary, additional precautionary measures to shield the concrete with plastic sheets or hessian during extreme warm, cold or windy weather conditions. Hessian shall be wetted should the conditions necessitate this. Curing methods shall be such that saturation and subsequent damage to soil foundations is prevented.

The Contractor shall make allowance in his rates for the abovementioned curing methods. Where the Contractor fails to cure for a minimum of 10 days, no payment shall be made for the relevant pour of concrete and the Engineer may demand the removal and replacement of such concrete.

**PSG5.5.9 Adverse weather conditions**

No placing of concrete shall take place if the ambient temperature is below 5°C, or exceeds 32°C, or is likely to drop below 5°C or rise above 32°C during the casting period or within eight hours after casting is completed.

If concrete is to be cast during times of high ambient temperature or hot drying winds, the Contractor shall be responsible for taking the necessary steps to keep the placement temperature as low as possible. Such steps include the spraying of the coarse aggregate with water, the painting of silos with reflecting aluminium paint, the insulation of tanks and pipelines, and the protection of concrete ingredients against the direct rays of the sun. The area of the pour shall be shaded before and during concreting and the concrete shall be shaded from the time of mixing until eight hours after placing.

Windbreaks shall be erected if necessary.

**PSG5.5.10 Concrete surfaces**

**PSG5.5.10.4 Screeded finish (Additional sub-clause)**

After placing and compacting, the concrete on a top (unformed) surface shall be struck off with a template to the designated grades and tamped with a tamping board to compact the surface thoroughly and to bring mortar to the surface, leaving the surface slightly ridged but generally at the required elevation. No mortar

shall be added, and noticeable surface irregularities caused by the displacement of coarse aggregate shall be made good by re-screeding after the interfering aggregate has been removed or tamped.

**PSG5.5.10.1 (a) Wood-floated finish.**

Where wood-floating is ordered or scheduled, the surface shall first be given a finish as specified in PSG5-6.1 and, after the concrete has hardened sufficiently, it shall be wood-floated, either by hand or machine, only sufficiently to produce a uniform surface free from screeding marks.

**PSG5.5.10.1 (b) Steel-floated finish**

Where steel-floating is specified or scheduled, the surface shall be treated as specified in PSG5-6.1 except that, when the moisture film has disappeared and the concrete has hardened sufficiently to prevent laitance from being worked to the surface, the screeded surface shall be steel-trowelled under firm pressure to produce a dense, smooth, uniform surface free from trowel marks.

**PSG5.5.11 Watertight concrete**

The floor, roof, columns and walls of the reservoir shall be constructed using watertight concrete. The Contractors shall abide by all conditions set out in sub-clause 5.5.11 and pay particular attention to this aspect of the works. The formwork/shutters shall be fastened using an approved imbedded fastening system. Open ferrules will not be permitted in the reservoir. No extra item shall be scheduled for payment under this sub-clause and the costs thereof shall be covered by the formwork and concrete rates.

**PSG5.5.13 Grouting**

“Unless otherwise specified on the drawings, grout for grouting holding down bolt pockets, column base plates or similar shall consist of either.....

- i) an approved proprietary non shrink grout (without metallic aggregate), or ....
- ii) a 2:1 sand cement grout mixed as dry as possible consistent with placing conditions.

Grout designated as dry packed shall be of such a consistency that it can be properly compacted by ramming. Where compaction by ramming is not possible, a proprietary flowable grout must be used. Grout shall have a minimum compressive strength at 20 days of 20 MPa”.

a) Water

Water for grout shall comply with the requirements given in Sub-clause 3.3 of SANS1200 G.

b) Aggregates

Notwithstanding the requirements of Sub-clause 3.4.1 of SANS1200G, the grading of fine aggregate (sand) and coarse aggregate (stone or pea gravel) shall conform to the gradings given in Tables 1 and 2 respectively:

Test sieve nominal aperture size (mm)	% Passing (by mass)
9.5	100
4.75	95-100
1.18	46-65
0.3 9 (300 um)	5-15
0.15 (150 um)	0-5

Test sieve nominal aperture size (mm)	% Passing (by mass)
9.5	100
4.75	95-100
2.36	0-5

c) Cement

Cement shall be ordinary Portland cement complying with the requirements of SANS 471.

d) Admixtures

Admixtures shall comply with the requirements of Sub-clause 3.5 of SANS 1200 G and shall have a proven record of satisfactory performance. All admixtures are to be approved by Engineer.

e) Proprietary grouting materials

Unless otherwise approved by the Engineer, proprietary grouting materials shall be obtained ready mixed in sealed pockets as supplied by the manufacturers.”

**PSG5.5.14 Defects**

All defects shall be repaired as soon as possible after the formwork has been removed and the Engineer has inspected the concrete. A statement of the method to be used for each repair shall be submitted to the Engineer for his approval before any work is carried out. The Engineer may prohibit the further placing of concrete in the particular area concerned until he is satisfied that the repair has been satisfactorily executed.

All honeycombing shall be repaired by cutting back to solid concrete and patching with a suitable epoxy mix to the approval of the Engineer.

**PSG5.5.15.a Concrete records**

For each casting the contractor shall keep records of:

- (a) Time elapsed between mixing and casting of concrete
- (b) Time elapsed between batches cast
- (c) Slump test results of each batch

**PSG5.5.15.16 "No-fines" concrete (Additional sub-clause)**

A nominal aggregate size of 19 mm shall be used in the manufacturing of "no-fines" concrete. No fines concrete shall be laid under where specified and shall consist of coarse aggregate, cement and water only. No fine aggregate shall be used.

The concrete shall be mixed in the following proportions:

Cement	:	50 kg
Aggregate	:	0,40 m <sup>3</sup>
Water	:	22,5 ℓ

The specified depth of the no-fines concrete shall be cast in one pour.

Between 24 h and 48 h after the no-fines layer has been laid it shall be covered with a 1:4 cement:sand mortar layer 20 mm thick. The mix shall be comparatively dry to ensure that it does not penetrate and block the cavities in the no-fines concrete. The surface shall be steel floated to form a plane surface. The mortar skim shall be cured in the same manner as concrete for a period of not less than 2 days.

Payment shall be per cubic metre of no-fines concrete placed. The rate shall include compaction and skimming to the approval of the Engineer.

**PSG5.17 Items to be cast in or grouted into concrete (Additional sub-clause)**

**PSG5.17.1 Casting pipes and specials in concrete**

Where entry holes for pipes/specials have been provided in the walls, the Contractor shall be responsible for the concreting in of such pipes/specials regardless of whether or not these have been supplied by himself.

The Contractor is responsible to ensure watertight fittings in the concrete to the Engineer's approval.

**PSG5.17.2 Fixings for equipment supplied under separate contract**

- a) The Contractor will be responsible for the forming of pockets if applicable to holding down bolts for equipment supplied under a separate contract. Holding down bolts will be supplied by and positioned by others.
- b) After casting of the concrete all shuttering shall be removed and the sides of the bolt holes and surface on which the machine base is to be placed shall be scabbled to remove all defective concrete, laitance, dirt, oil, grease and loose material.
- c) Upon completion of the positioning and alignment of equipment and when instructed by the Engineer the Contractor shall in collaboration with the mechanical contractor, grout up pockets and baseplates by filling pockets and voids under the baseplates with an approved non-shrink grout.

**PSG5.17.3 Fixings for items supplied under this Contract**

Holding down bolts or other fixings required for the installation of items supplied under this Contract shall be provided by the Contractor. These fixings shall be cast in or grouted into pockets or installed by other means as approved by the Engineer.

Where anchor bolts are used which are installed into holes drilled into concrete or masonry these shall be of a type approved by the Engineer. All such bolts used shall be manufactured from stainless steel or a metal with a resistance to corrosion equal to that of grade 304 stainless steel. The metal used for bolts shall be compatible with galvanized mild steel.



Anchor bolts shall have minimum pull-out forces and minimum ultimate lateral loads at least equal to those specified below:

Specified Anchor Size	Minimum Pull-out Force (kN)	Minimum Ultimate Lateral Load (kN)
M6	10,35	7,60
M8	13,70	11,15
M10	19,44	15,95
M12	31,85	26,90
M16	50,45	45,80
M20	60,50	71,20

**PSG5.18 Supervision**

Prior to carrying out any concrete work, the Contractor shall obtain the approval of the Engineer in respect of:

- (a) Structural programme
- (b) Description of casting sequence
- (c) Concrete plant details
- (d) Materials to be used in concrete
- (e) Details of concrete
- (f) Construction joints

**PSG7 Testing**

**PSG7.1.2 Frequency of sampling**

One sample shall consist of three concrete test cubes.

For each sample taken the position in the structure shall be recorded where the batch represented by that sample is placed.

Sampling of concrete of a particular grade shall be as specified in Subclause 7.1.2 with the following frequency of sampling referred to in Subclause 7.1.2.2 being amended to read as follows:

"A minimum 2 samples for 50 m<sup>3</sup> (or less) of pour shall be taken for each grade cast on any day."

**PSG7.2.4 Early-Strength Testing**

7 day tests shall be performed on 1 sample for 50 m<sup>3</sup> (or less) of pour. These results shall be submitted to the Engineer as soon as possible after testing.

**PSG7.4 Grouting (Additional sub-clause)**

The Contractor shall, where so ordered, carry out a site test for each grouting procedure and each grouting gang to be used. The tests shall be carried out on a dummy bedplate similar in configuration to that which

is to be grouted, but not exceeding 1 m<sup>2</sup> in area unless otherwise ordered. When the dummy bedplate is dismantled, the underside shall show a minimum grout contact area of 80% with reasonably even distribution of the grout over the surface grouted except that, in the case of expanding grout, the minimum grout contact area shall be 95%. The test shall show evidence of good workmanship and materials and the results shall be to the satisfaction of the Engineer.

The Contractor shall, when so ordered, make standard test cubes from various grout mixtures and also subject them to compression tests to determine whether the specified strength has been achieved. Test procedures shall comply with the relevant requirements of Subclauses 7.2.1 to 7.2.3.

**PSG7.4.1 Concrete properties**

Acceptance criteria for concrete properties are stated below.

**PSG7.4.1.1 Water sorptivity and oxygen permeability**

<b>Table PSG 7.3.6.1 Water Sorptivity and Oxygen Permeability</b>		
<b>Acceptance Category</b>	<b>Test No. / Description / Unit</b>	
	<b>Water Sorptivity (mm/h)</b>	<b>Oxygen Permeability (log scale)</b>
Concrete made, cured and tested in laboratory	6	> 10.0
Full acceptance of in-situ cast concrete	< 8	> 9.15
Conditional acceptance of in-situ cast concrete (with remedial measures)	8 - 15	8.75 – 9.15
Rejection	> 15	< 8.75

**PSG7.4.1.2 Chloride conductivity**

<b>Table PSG 7.3.6.2 Chloride Conductivity (severe to very severe conditions)</b>								
<b>Concrete</b>	<b>100% PC</b>		<b>10% CSF</b>		<b>30% FA</b>		<b>50% GGBS</b>	
<b>Curing Period</b>	<b>28d</b>	<b>90d</b>	<b>28d</b>	<b>90d</b>	<b>28d</b>	<b>90d</b>	<b>28d</b>	<b>90d</b>
Full wet cured	1.25	1.00	0.50	0.45	1.50	0.40	1.25	1.00
Moist cured (3 – 7d)	1.75	1.60	0.60	0.55	2.25	1.25	2.25	2.00

**PSG7.4.1.3 Concrete cover**

<b>Table PSG 7.3.6.3 Concrete Cover</b>			
<b>Test Description</b>	<b>Specified Cover (mm)</b>	<b>Acceptance Range</b>	
		<b>Minimum</b>	<b>Maximum</b>
Concrete cover to reinforcement	20 – 30	As specified	As specified + 5 mm
	30 - 80	As specified	As specified + 10 mm

**PSG8 Measurement and payment**

**PSG8.1.1 Formwork**

**PSG8.1.1.7 Edges of blinding layer or “no-fines” concrete (Additional sub-clause)**

No separate payment will be made for formwork to the edge of the blinding or “no-fines” concrete (refer to PSG5-10) layer. The rates tendered for concrete to the blinding or “no-fines” concrete layer shall cover the cost of such formwork.

**PSG8.1.1.8 Kickers** Unit: m<sup>2</sup>

No separate payment will be made for formwork to the edges of kickers. The rates tendered for successive walls or columns formwork shall cover the cost of such formwork.

**PSG8.1.1.1 & 8.1.1.2 Chamfers and fillets**

No additional payment will be made for chamfers and fillets up to 40 mm wide. Larger fillets and chamfers will be measured by length in accordance with Subclause 8.2.5.

**PSG8.1.2.2 & 8.1.2.3 Reinforcement** Unit: tonne

Notwithstanding the method of measuring and paying for reinforcement specified in Subclauses 8.1.2.2 and 8.1.2.3, reinforcement will be measured and paid for as scheduled.

**PSG8.1.3 Concrete** Unit: m<sup>3</sup>

The rates for concrete shall also cover:

- a) the use of dolomitic aggregate where prescribed,
- b) the cost of the preparation of design mixes by an approved laboratory and submission for approval by the Engineer (see PSG5-3.1),
- c) the cost of non-designated joints (see PSG2-4),
- d) screeded finish of unformed surface as specified,
- e) inclusion of admixtures where specified, and
- f) necessary admixtures to ensure watertight concrete.

**PSG8.1.4 No-fines concrete** Unit: m<sup>3</sup>

No-fines concrete (refer to PSG5.5.15.16) will be measured by volume.

The rate shall cover the cost of supplying materials, constructing and placing in position the no-fines concrete, and shall include for the steel floated 20 mm mortar skim.

**PSG8.4.4 Unformed surface finishes** Unit: m<sup>2</sup>

The rates for unformed surface finishes shall cover the cost of providing the respective surface finish as specified in PSG5-6.

**PSG8.5 Joints**

Only designated joints as shown on the drawings will be measured for payment according to the length of each type of joint constructed (see PSG2.4.3). The rate shall cover the cost of all materials, labour and plant required to construct each type of joint specified on the drawings, including the cost of all shuttering, treatment of the joint as specified in Subclause 5.5.7.3, the provision of chamfers as specified where concrete is exposed, as well as testing and repairing where necessary.

Non-designated joints will not be measured for payment.

**PSG8.5.1 Formed joints** Unit: m<sup>2</sup>

Formed joints will be measured by the plane area of the joint.

The rates shall cover the cost of all operations and materials specified in Subclause 5.5.7 and PSG5.5.7.4, and detailed on the drawings such as joint filler, dowel bars and tubes, bitumen coats, etc., but excluding waterstops or waterbars.

Waterstops and waterbars will be measured by length separately for each type.

**PSG8.5.2 Holding down bolts** Unit: No.

Fixing of holding down bolts will be measured by number. The rate shall cover the cost of all things necessary to ensure that the bolts are effectively and rigidly held in position during casting, complete with sleeved pockets, all as detailed on the drawings.

**PSG8.7 Grouting** Unit: m<sup>3</sup>

Grouting of base plates and equipment bases will be measured by the volume of grout used.

The rate shall cover the cost of the supply and floating in of grout under the plates to ensure solid and complete filling of the gap.

**PSG8.9 Items cast in concrete** Unit: No.

Items cast in concrete will be measured by number separately for each type of item.

Notwithstanding Subclause 8.2.6, the rate shall cover the cost of fixing in position and casting in the item as construction proceeds, irrespective of whether the Contractor chooses to fix the item in the formwork and cast it in directly or to box out a hole and grout the item in subsequently.

The item will be measured and paid separately.

**PSG8.10 Precast concrete cover planks** Unit: m<sup>2</sup>

Precast paving slabs will be measured by the area paved.

The rate shall cover the cost of compacting the area, application of weed-killer, supplying, laying and bedding the slabs, grouting the joints and filling any gaps, all as specified.

**PSG8.11 PFA concrete**

Measurement and payment for PFA concrete shall be as specified in Subclause 8.1.3.

The tendered rate shall cover all costs in connection with the supply, storage, handling on site and mixing in of PFA.

**PSG8.12 Poly-urethane sealants** Unit: m

A one part polyurethane sealant shall be used in the outside joint between the reservoir roof and walls to the details shown and shall be finished off neatly leaving a smooth regular finish.

Payment shall be per linear metre. The rate shall include the supply, preparation, sealing and finishing.

**PSG8.13 Manhole covers** Unit: No.

Manhole covers shall be paid per unit.

**PSG8.14 Commercial Laboratory**

Unit: Prov Sum

A Provisional Sum for the services of a commercial laboratory has been included in the Bill of Quantities for the Engineer's Acceptance Testing. The use of this laboratory is for additional testing required over and above the testing specified in SANS 1200 G and the variations to SANS 1200 G specified above. Testing shall only be paid on written instruction for additional testing from the Engineer.

The procedure for sampling and manufacturing, storing, curing and testing cubes shall be in accordance with SABS 863.

**PSHA                    STRUCTURAL STEELWORK (SUNDRY ITEMS). (SANS 1200 HA)**

**PSHA3                Materials**

Where the words "Structural Steelwork" appear in the heading and in other relevant Clauses, amend to read "Aluminium, Stainless Steel and Structural Steel".

**PSHA3.1             Structural steelwork**

Structural steelwork shall comply with Grade 43 of BS 4360.

**PSHA3.1.1          Stainless steel (Add Subclause)**

All stainless steel items shall be Grade 304L material.

**PSHA3.1.2          Aluminium (Add Subclause)**

All aluminium items shall be grade M57S material anodized in accordance with SABS 199 Grade 25.

**PSHA3.3             Bolts and nuts**

All bolts, nuts and washers within water retaining structures or exposed to the rain, or with a diameter of 10 mm or less, all anchor bolts of any size in concrete or brickwork and all bolts of any size used in conjunction with stainless steel items, shall be manufactured from Grade 304L stainless steel.

All other bolts, nuts and washers with a diameter of 12 mm or greater shall be hot dip galvanized to SABS 763. Nuts shall be tapped before galvanizing, taking into consideration the extra clearance necessary to allow for the thickness of galvanizing on the bolts. If, after installation, there is any indication that galvanising has been stripped from either the nut or the bolt, both nut and bolt shall be removed and replaced.

**PSHA3.5             Access ladders (Add Subclause)**

Access ladders shall be constructed and installed as per detail drawings. Access ladders shall be fixed to the walls using chemset bolts. The necessary precaution shall be taken to ensure watertightness of the walls.

**PSHA3.6             Vermin proof flaps (Add Subclause)**

Vermin proof flaps shall be made of stainless steel.

**PSHA4                Plant**

The Engineer may request at any time the mill certificate of the steel supplier.

All components shall be pre-fabricated in an Engineer approved steel fabrication yard. No site fabrication or welding will be permitted.

**PSHA5                Construction**

**PSHA5.2.4          Welds**

All welds shall be fully continuous and not less than 6mm across the throat.

**PSHA5.2.5 Bolts**

All bolts and nuts shall be hexagonal type Grade 8.8 with threads of coarse pitch series and shall be hot dip galvanised in accordance with the requirements of SANS ISO 1461.

Before assembly, all bolts shall be coated with an approved nickel based Anti-seizure/corrosion protection compound.

Two washers shall be used with every bolt and nut to prevent damage to coatings.

**PSHA7 Testing**

All welds shall be crack tested using die indicators.

**PSHA8 Measurement and payment**

**PSHA8.3.6 Corrosion protection**

Notwithstanding the requirements of Subclause 8.3.6, corrosion protection (painting and galvanizing) will not be measured separately, the prices tendered for the steel items being held to include for the cost of corrosion protection as specified.

**PSHA8.3.7 Stainless steel manhole frame and cover** Unit : No

Sub-clause PS HA 5.4 applies to this payment item.

The rate shall cover all costs for the manufacture, supply, installation and casting-in of the frame into the surrounding concrete complete with locking device and padlock.

**PSHA8-3 Reservoir roof ventilation pipe complete** Unit: No.

Sub-clause PS HA 5.5 applies to this payment item.

The rate shall cover the costs for the fabrication, galvanising, casting-in and installation of the ventilator pipe to its completion.

**PS HA 8.4 Stainless steel cat ladders inside the sump** Unit: Lump Sum

The rate shall cover the manufacture, supply, installation and commissioning of the ladder, including all fixing features, complete."

**PSHC CORROSION PROTECTION OF STRUCTURAL STEELWORK**  
(SANS 1200 HC)

**PSHC5 Construction**

**PSHC5-1 Structural steel**

All structural steel members shall be hot dip galvanized.

**PSHC5.11 Floor panels, handrails, ladders and the like** (Add Subclause)

The open grid and chequer plate flooring panels and frames, handrails, ladders and similar items shall be hot dip galvanized in accordance with the requirements of Subclause 5.9.

In addition handrails shall be degreased, primed and painted yellow with two coats of recoatable polyurethane to a minimum total dry film thickness of 70 micrometers after installation.

**PSHC6            Tolerances**

**PSHC6.6        Film thickness tolerances**

**PSHC6.6.1     Individual coatings**

At least 90% of all thicknesses measured shall comply with the minimum thickness of the system specification. Up to 10% of all readings may be below the specific minimum thickness, but no reading shall be less than 70% of the specified minimum thickness.

**PSHC6.5        Total dry film thickness**

Not more than 10% of readings shall be less than the minimum specified and no reading shall be less than 90% of the specified minimum. For immersion conditions no reading shall exceed the mean specified thickness by greater than 60% of the minimum, unless a concession is granted by the Engineer.

**PSHC8           Measurement and payment**

PSHA8.3.6 shall apply.



**PROJECT SPECIFICATION: PORTION 2**

**SABS 1200 PS LE: STORMWATER DRAINAGE**

**PS LE 3 MATERIALS**

**PS LE 3.1.1 Material for Subsoil Drainage**

PS LE 3.1.1.1 Pipes

Pipes for subsoil drainage shall be uPVC pipes complying with the requirements of SABS 791, but shall be perforated or slotted.

The size of perforations in perforated pipes shall in all cases be 8 mm in diameter  $\pm$  1,5 mm and the number of perforations per metre shall be not less than 26 for 110 mm pipes and 52 for 160 mm pipes. Perforations shall be spaced in two rows for 110 mm pipes and in three rows for 160 mm pipes.

Slotted pipes shall have a slot width of 8 mm  $\pm$  1,5 mm. The arrangement of slots shall be subject to the Engineer's approval, but the total slot area shall be not less than that presented for perforations.

Pipes without slots or perforations required for conveying ground water from the subsoil drainage proper to the point of discharge, shall be uPVC pipes as specified above.

PS LE 3.1.1.2 Crushed stone

Crushed-stone in subsoil drains shall be 19 mm single-sized stone complying with the grading requirements of stone for concrete in SABS 1083.

PS LE 3.1.1.3 Geotextile Blanket

The geotextile blanket around subsoil drains shall comply with the requirements of PS DK 3.1.4 in all respects.

PS LE 3.1.1.4 Sand

Sand obtained from approved commercial sources shall be clean, hard and durable and shall comply with the following grading requirements:

D15 : 0,2 mm to 0,4 mm  
D85 : 1,2 mm to 4,7 mm

**PS LE 5 CONSTRUCTION**

**PS LE 5.1 Trench Bottom**

PS LE 5.1.3 Unsuitable Founding Conditions

Substitute "90 % of MAASHTO maximum density" in LE 5.1.3 with "90 % of MAASHTO maximum density (100 % for sand)".

**PS LE8.2 BEDDING AND LAYING**

PS LE 8.2.14 Supply and Install Subsurface Drains According To Drawings ..... Unit: m

The length shall be measured on the centre line of the completed subsurface drain.

The rate shall cover the cost of supplying, transporting, off-loading and installing all materials as well as for cutting, wasting, overlapping and installing of the materials where applicable.

**PARTICULAR SPECIFICATION: PA**

**BRICKWORK AND PLASTER**

**PA1 SCOPE**

**PA1.1** This specification covers the general requirements for buildings and other masonry structures, including plastering.

**PA2 INTERPRETATION**

**PA2.1 Other relevant Standards/Specification**

This specification should be read together with SABS 1200 AA.

**PA2.2 Applicable Edition of Standards**

Each standard specification referred to in this specification shall be deemed to be the latest edition, applicable on the tender closing date.

**PA2.3 Definitions and Symbols**

For purposes of this specification, the definitions and symbols given in the National Building Regulations and Building Standards Act, 1977 (referred to further on in this specification as "Building Act"), where applicable, shall apply. (Definitions: pages 5 to 14, Symbols: page 23.)

**PA3 MATERIALS**

**PA3.1 Cement**

Cement shall conform to the requirements of SABS 471.

**PS3.2 Lime**

Lime shall be of approved manufacture, well burnt and of uniform quality conforming with SABS 523.

**PA3.3 Sand**

Sand to be used for mortar and plaster shall comply with the requirements of SABS 1090.

**PA3.4 Clay Bricks**

Clay bricks must conform to SABS 227. A sample of bricks to be used for construction must be given to Engineer for approval before construction bricks are delivered to site.

The contractor will be required to carry out necessary tests and provide certificates for compliance of the bricks with SABS 227. The cost of these tests will be deemed part of the scheduled rates and no additional payment will be made therefore.

Best quality engineering bricks shall be used for all foundation and concealed situations.

**PA3.5 Damp-Proofing**

Material used as a damp proof course shall conform to the requirements contained either in SABS 248 or in SABS 952. Type FV fibre-felt sheets or Type C polyethylene sheets shall be supplied under the contract.

**PA3.6 Fibre Cement Sheets**

Fibre cement flat sheets, minimum 15 mm thick, shall comply with the requirements of SABS 685.

**PA3.7 Storage**

**PA3.7.1 Cement and Lime**

Cement and lime stored on the site shall be properly protected against moisture to the satisfaction of the engineer.

**PA4 CONSTRUCTION**

**PA4.1 Brickwork**

Brickwork shall be well and regularly bonded, with no false headers and none but whole bricks except where legitimately required as closers. All bricks must be thoroughly dampened before laying and each brick is to be laid with full joints and pressed into its bed so as to squeeze out superfluous mortar and give a finished joint not exceeding 8 mm thick in the case of the face work or 13 mm thick in the case of plastered walls or work not exposed to view.

All joints, both horizontal and vertical, notwithstanding any grade custom to the contrary, are to be filled solid with mortar for their full width and depth, each course being flushed with mortar, worked well down into all vertical joints before the succeeding course is laid. Horizontal joints and vertical joints of face work shall be pointed flush in manholes and catch pits, but shall be pointed and finished with a tooled recessed joint elsewhere. Plastered walls shall have the joints raked out to a depth not less than 13 mm and not more than 20 mm, and subsequently refilled with mortar of the same proportions as the original bedding mortar. In no circumstances may joints be so formed as to expose any perforation in the units.

Wire ties, where required, shall be stainless steel and are to be installed at 5 per square metre.

**PA4.2 Mortar**

The mix proportions for the mortar are given below:

Portland cement	50 kg
Lime	0-40 l
Sand*	200 l max.

\* measured loose and damp

**PA4.3 Plastering**

Plaster shall be of the same proportions as the bedding mortar. Any other plaster mixes will be subject to the approval of the Engineer.

**PA4.4 Damp Proof Courses**

The areas to be covered by damp proof courses are indicated on the drawings. Damp proof shall be laid on a surface which shall not contain any sharp objects which may perforate the membrane. The full width of the wall and the whole area under the floor is to be covered by the membrane and shall overlap by not less than 100 mm under the floor, and by not less than 150 mm under the wall. All joints shall be effectively sealed. Where shown on the drawing, the damp proof course is to be stepped up one course of brickwork in the inner skin.

**PA4.9 Floor Finishes**

**PA4.9.1 Granolithic Floor Screed**

Granolithic shall consist of one part cement, one part sand and two parts 5 mm stone chips and oxide where required, thoroughly mixed as for concrete and placed in a layer not less than 20 mm thick, levelled or graded and trowelled to a smooth uniform surface. To ensure proper bond, the concrete surface to be covered shall be clean, roughened by chipping, flushed with water and coated with cement grout just before placing of the granolithic layer. Granolithic finish is to be steel floated with V joints in squares of 1,20 m to 1,80 m, the joints extending for the full depth of the granolithic. Joints are not required in the granolithic screed where it is to be overlaid by tiles or carpeting.

**PA4.11 Weather**

In any period of interruption caused by inclement weather, and at the completion of each day's bricklaying, freshly laid brickwork should be protected.

**PARTICULAR SPECIFICATION PC****VALVES****PC 1 GATE VALVES**

Gate Valves shall bear the official mark of SABS and be SABS approved. They shall comply with SABS 664 for waterworks pattern valves of the types, classes and sizes listed in the Schedule of Quantities and shall be provided with the following:

	Description	Specification
1	Flanges	Double flanged, to be in accordance with and drilled off-centre to SABS 1123, Table 1600, 2500 or 4000 as scheduled.
2	Spindles	Non rising, bronze or stainless steel with spindle nut either bronze or gunmetal
3	Handwheels	Direction of rotation for opening valves shall be clockwise when viewed from the top and appropriate wording must be embossed at the top indicating direction of "close" and "open" with arrow heads
4	Tests	Valves to be subjected to "closed end" and "open end" pressure tests to one and half times the working pressure. Valve body shall be tested to twice working pressure. Under all the tests, no leakage to occur
5	Paint	As in PD4
6	Other	<ul style="list-style-type: none"> <li>• Type B gunmetal trim</li> <li>• Valves should permit repacking of the gland whilst valve is under pressure</li> <li>• Factory test certificates to be provided with each valve</li> <li>• Rates in the schedule of quantities to include requirements to comply with specification</li> </ul>

**PC 2 REFLUX VALVES**

Reflux valves shall, except where otherwise specified, be double flanged single door swing type and shall be fitted with gun metal seats and bronze hinge and clack pins. In the case of reflux valves to be mounted horizontally, the design shall be such that the gate rests against the seat in the absence of flow or of differential pressure, without the aid of springs or external counterweights. Reflux valves shall comply with the requirements of SABS 144 for working pressures as required for each application, but not less than 1600 kPa working pressure.

**PC 3 AIR VALVES****PC 3.1 General**

The materials and workmanship employed in the manufacture of air valves shall be of a similar standard to that set out in SABS 664 for waterworks pattern gate valves and they shall be provided with individual test certificates for each valve from the manufacturer; all valves are to be inspected, and the hydraulic tests witnessed, by an Inspector to be appointed by the Engineer, and the tendered rates for the valves shall include for making arrangements for independent inspections. The Inspectors' fee and recoverable expenses will be for the account of the Employer, fees and expenses arising from abortive or repeat visits due to non-compliance with the specified requirements will be for the Contractor's account and will be deducted from amounts due to the Contractor.

### PC 3.2 Types of Air Valves

Air Valves shall be standard types (epoxy coated flanges; stainless steel sleeve, bolts, nuts, studs etc), of the double orifice type, and shall be equal or similar to the "Vent-O-Mat" (RBX series: 50 mm dia valves: 050 RBXc2511; 80 mm valves: 080 RBXc1601) type in which a small orifice, manufactured from Grade 316 stainless steel and having a minimum orifice size of 2,0 mm diameter, shall be capable of releasing accumulations of air at all pressures throughout the specified working pressure range and shall be drop-tight at 0,5 Bar. The large orifice shall be suitable for admitting or expelling large quantities of air during emptying and filling of the pipeline. The opening of the valve (to atmosphere) shall be enclosed by a stainless steel mesh which has been fixed into the valve body to prevent the entry of small insects or vermin into the valve.

All welding of stainless steel shall be carried out in workshops dedicated to the fabrication of stainless steel products. Care shall be taken that the correct welding rods and approved welding procedures have been used for each application, and the Engineer shall have the right to request a certificate from the manufacturer in which the weld procedures used for the manufacture of valves supplied are stated.

All welds and weld beads, internal and external, shall be smoothed down by grinding and buffing. All stainless steel shall be pickled and passivated before the valve is assembled and tested.

### PC 3.3 Testing

Each air valve is to be subjected to the following tests at the factory :

- (a) First, fill the valve with water and apply the factory test pressure through the inlet of the valve. Under this condition there shall be no weeping from any part of the valve.
- (b) Second, drain the valve and refill the valve with water and apply the maximum working pressure through the inlet of the valve and maintain for at least five minutes. Under this condition there shall be no loss of water from the valve.
- (c) Third, gradually reduce the pressure applied under (b) above to atmospheric pressure, empty the valve and refill slowly expelling the air through the valve until it is full of water. Raise the pressure to the minimum working pressure, maintain that pressure for at least five minutes and again there shall be no loss of water from the valve.
- (d) Fourth, maintain the minimum working pressure applied in (c) above, isolate the water inlet and introduce small amounts of compressed air into the valve without lowering the pressure in the valve. The lower float shall drop away from the upper float when sufficient air has accumulated in the valve. As soon as the accumulated air in the valve has discharged through the small orifice, the valve shall again close to a watertight condition. This process shall be repeated for at least five different pressures which are equally spaced between the specified minimum and maximum operating pressures, and the valve shall close automatically when all the air has escaped without any dribbling and shall have a drop-tight shut-off.

## PC 3.4 Table of Particular Requirements for Air Valves

Scheduled Items			
Nominal diameter (mm)		80	25/50
Class		25	16
Flange Size and Rating		SABS 1123 Table 2500	SABS 1123 Table 1600
Flange Drilling		SABS 1123 Table 2500	SABS 1123 Table 1600
Factory Test Pressure (metres head of water)		250	160
Field Test Pressure (metres head of water)		as for pipeline	as for pipeline
Working Pressure (metres head of water) :			
(a) Maximum		250	160
(b) Minimum		200	120

**PC 4 PAINTING OF VALVES**

PC 4.1 The cleaning and painting of valves as specified hereunder is to be carried out at the factory prior to despatch to site.

PC 4.2 All cast iron surfaces of every valve shall be prepared for painting to a thoroughly clean condition free of all grease and deleterious matter. Steel surfaces shall be prepared in accordance with Swedish Standard SIS 05 5900 for a Sa 2.5 finish.

PC 4.3 Internal surfaces shall then be treated with two coats of Copon Hicote 151E or other approved non-toxic epoxy resin paint to give a total minimum dry film thickness of 160 micrometres; both coats being applied within 48 hours of commencement of painting.

PC 4.4 External surfaces shall, immediately after cleaning, be treated with one of the following alternative paint systems:

- (a) System 1 - for valves situated in underground chambers or exposed conditions.

Apply three coats of an approved epoxy coal tar paint to give a minimum total dry film thickness of 240 micrometres; all three coats being applied within 72 hours of commencing the first coat.

- (b) System 2 - for valves situated in pump stations etc.

Apply one coat of zinc chromate primer followed by one coat of undercoat tinted where necessary, and a final coat of best quality gloss enamel. The total dry film thickness of the system shall be not less than 200 micrometres.

PC 4.5 Non-ferrous metal or stainless steel surfaces shall not be painted.

PC 4.6 After erection on site all valves shall be cleaned and the paint work refurbished where necessary to restore the condition to that at the time of leaving the factory.



**PC 5 PAYMENT**

The prices quoted for all valves are to include for independent factory testing of valves, which test will be witnessed by Inspectors appointed by the Engineer.

**PROJECT SPECIFIC OCCUPATIONAL HEALTH AND SAFETY SPECIFICATION**

**FOR**

**UMZIMKHULU BULK SEWER**

**CONTRACT No. HGDM 759/HGDM/2022**

**CONSTRUCTION OF UMZIMKHULU BULK SEWER OUTFALL**

**MANAGED ON BEHALF OF**



**HARRY GWALA DISTRICT MUNICIPALITY  
(THE "CLIENT")**

**KEY ROLE PLAYERS**

**CLIENT**

Principal Agent:

Civil Engineer

Quantity Surveyor

Land Surveyor

Mechanical Engineer

Environmental Control Officer

Health and Safety Agent

**PRINCIPAL CONTRACTOR**

Contracts Manager

Site Agent

H&S Officer

Other:

## TABLE OF CONTENTS

1.	LIST OF ABBREVIATIONS .....	SW85
2.	DEFINITIONS .....	SW86
3.	KEY REFERENCES.....	SW87
4.	INTRODUCTION.....	SW87
4.1	Purpose of the Project Specific Health and Safety Specification (PSHSS) .....	SW87
4.2	Implementation of the Project Specific Occupational Health and Safety Specifications (PSHSS).....	SW88
4.3	Requirements at Tender Stage .....	SW88
5.	GENERAL REQUIREMENTS.....	SW89
5.1	Summary of Risks identified during Design .....	SW89
5.2	Specified Hazardous Chemical Substances .....	SW89
6.	OCCUPATIONAL HEALTH & SAFETY MANAGEMENT.....	SW90
6.1	Structure and Organization of H&S Responsibilities .....	SW90
6.1.1	Notification of Commencement of Construction Work.....	SW90
6.1.3	Appointment of Competent Site Personnel.....	SW91
6.1.4	Construction Supervision .....	SW91
6.1.5	Construction Health and Safety Officer.....	SW91
6.1.6	Traffic Safety .....	SW92
6.1.7	Health and Safety Representatives and H&S meetings .....	SW92
6.1.8	Appointment of Competent Contractors.....	SW93
7.	GENERAL RISK MANAGEMENT.....	SW93
7.1	Health Risks and Medical Surveillance.....	SW93
7.2	Noise Risks .....	SW94
7.3	Emergency Procedures.....	SW94
7.4	First Aiders and First Aid Equipment .....	SW94
8	Fires and Emergency Management.....	SW95
7.6	Incident Management and Compensation Claims.....	SW95
7.7	Personal Protective Equipment (PPE) and Clothing .....	SW95
7.8	Occupational Health and Safety Signage .....	SW95
7.9	Induction of Employees and Visitors, General H&S Training.....	SW96
7.10	Management of Plant and Equipment .....	SW96
7.11	Excavations .....	SW96
7.12	Working at heights .....	SW97
7.13	Cranes and lifting equipment.....	SW97
7.14	Temporary Works (Scaffolding, support work, formwork).....	SW97
7.15	Auditing .....	SW98
7.16	Mechanical installations .....	SW98

**HARRY GWALA DISTRICT MUNICIPALITY**

**CONSTRUCTION OF UMZIMKHULU BULK SEWER OUTFALL**

**HGDM 759/HGDM/2022**

---

7.17	Communication on Site .....	SW98
7.18	Care of Workers on Site (Welfare).....	SW98
7.19	Discipline, Alcohol and Substance Abuse.....	SW98
7.20	Electrical Equipment .....	SW99
7.21	HIV and AIDS Programme .....	SW99
7.24	Safety Conflict .....	SW99
8.	HEALTH AND SAFETY FILE .....	SW100
9.	NON-CONFORMANCES .....	SW100
9.1	Failure to Comply with Provisions .....	SW101
10.	MEASUREMENT AND PAYMENT .....	SW101

**ANNEXURES**

ANNEXURE A:	EXAMPLE HEALTH AND SAFETY AUDIT DOCUMENT
ANNEXURE B:	CLOSE OUT REQUIREMENTS
ANNEXURE C:	NON-CONFORMANCES
ANNEXURE D:	CONTRACTORS MONTHLY HEALTH AND SAFETY REPORT
ANNEXURE E:	RISK ASSESSMENT FORMAT
ANNEXURE F:	BILL OF QUANTITIES FOR OCCUPATIONAL HEALTH AND SAFETY
ANNEXURE G:	HEALTH AND SAFETY (H&S) PRE-TENDER REPORT
ANNEXURE H:	TENDER STAGE OHS PLAN EVALUATION
ANNEXURE I:	MANDATORY AGREEMENT

## 1. LIST OF ABBREVIATIONS

AIA	Approved Inspection Authority
BoQ	Bill of Quantities
CC	Compensation Commissioner
CR	Construction Regulations
DMR	Driven Machinery Regulations
DoL	Department of Labour
FEMA	Federated Employers Mutual Association
GAR	General Administration Regulations
GSR	General Safety Regulations
HCSR	Hazardous Chemical Substances Regulations
HIRA	Hazard Identification Risk Assessment
H&S	Health and Safety
ER	Engineer's Representative
LI	Labour Intensive
OH	Occupational Health
OHSA	Occupational Health and Safety Act No. 85 of 1993 (as amended)
OHSS	Occupational Health and Safety Specification
PSHSS	Project Specific Health and Safety Specification
PC	Principal Contractor
PPE	Personal Protective Equipment
SANS	South African National Standards (Authority)
MSDS	Material Safety Data Sheet
SMME	Small, Micro, Medium Enterprise
SWP	Safe Work Procedure

## 2. DEFINITIONS

The definitions used will be those set out in the Construction Regulations, Gazette No 37305 of 7 February 2014 which are hereunder further emphasised with the following additions:

**Client:** Harry Gwala District Municipality

**Construction Site:**

Means a work place where construction work is being performed

**Construction Supervisor:**

Means a competent person responsible for supervising construction activities on a construction site

**Designer:** Means a competent person appointed by the Client as Agent to design, supervise and monitor construction on their behalf.

**Fall Risk:** Means any potential exposure to falling either from, off or into

**Hazard:** Source of or exposure to danger

**Hazard Identification and Risk Assessment (HIRA) and Risk Control:**

Means a documented plan, which identifies hazards, assesses the risks and details the control measures and safe working procedures which are to be used to mitigate and control the occurrence of hazards and risks during construction or operation phases.

**Health and Safety Agent:**

Means any competent person who acts as a representative for the Client in managing the projects health and safety and who is registered with the South African Council for the Project and Construction Management Profession (SACPCMP).

**Health and Safety Plan:**

Means a site, activity or project specific documented plan in accordance with the Clients Health and Safety Specification.

**Induction Training:**

Means once off introductory training on general health and safety issues given to all employees and visitors to the site before commencement of work on site.

**Risk:** Means the probability or likelihood that a hazard can result in injury or damage.

**Regulation/s:**

Shall mean the relevant regulation/s promulgated in terms of the Occupational Health and Safety Act, No. 85 of 1993.

**Temporary Works:**

Means any falsework, formwork, support work, scaffold, shoring or other temporary structure designed to provide support or means of access during construction work

**The Act:** Means, unless the context indicates otherwise, the Occupational Health and Safety Act, No. 85 of 1993 and Regulations promulgated thereunder, as amended.

### 3. KEY REFERENCES

The following key references apply to the specifications:

- Occupational Health and Safety Act No. 85 of 1993 and Regulations (as amended)
- Compensation for Injury and Occupational Diseases Act No. 100 of 1993 (as amended)
- SANS Code 1921-6
- SANS Code 1200

### 4. INTRODUCTION

Harry Gwala District Municipality is responsible for the provision of adequate and reliable potable water and sanitation services within the district and takes cognizance that its current scope of works pose inherent risks to the health and safety of its agents and members of the public.

Each year fatalities, serious injuries and poor attitudes of Contractors mar the reputation of the Construction Industry. Harry Gwala District Municipality has a responsibility to limit its risk by ensuring a zero tolerance and better practice approach to Contractors and those affiliated to a particular project. Thus a high premium is placed on the health and safety (H&S) of Harry Gwala District Municipality stakeholders, which include its employees, professional service providers, public and its physical assets. The responsibilities that the Harry Gwala District Municipality and relevant stakeholders have toward its employees are captured in, but not limited to this document. The responsibilities stem from both moral, civil and a variety of legal obligations. The Principal Contractor is to take due cognizance of the above statement.

Harry Gwala District Municipality, as the Client and where there is an appointed H&S Agent on its behalf, shall provide a project specific Health & Safety Specification (PSHSS) for the project and provide the Principal Contractor/s making a bid or appointed to perform construction work for the project, or parts thereof.

#### 4.1 Purpose of the Project Specific Health and Safety Specification (PSHSS)

The PSHSS is a performance specification to ensure that the Client and any bodies that enter into formal agreements with the Client viz. Agents, Professional Service Consultants (Engineers, Quantity Surveyors and Land Surveyors), Principal Contractors and Contractors achieve an acceptable level of OHS performance. No advice, approval of any document required by the PSHSS, such as hazard identification and risk assessments, or any other form of communication from the Client shall be construed as acceptance by the Client of any obligation that absolves the Principal Contractor from achieving the required level of performance and compliance with legal requirements. Furthermore, there is no acceptance of liability by the Client, which may result from the Principal Contractor failing to comply with the PSHSS, i.e. the Principal Contractor remains responsible for achieving the required performance levels.

A Mandatory Agreement in terms of Section 37.2 of the OHSA will be signed between parties prior to any works commencing.

The PSHSS highlights the aspects to be implemented over and above the minimum requirements of current legislation. Requirements may be changed should new risks or issues are identified that could not have been foreseen during the design phase of the project, or during the construction phase. Any new legislation or standards (legislated, or determined by Harry Gwala



District Municipality) that are promulgated or accepted during the contract will automatically be applied.

Environmental management shall receive due attention as per the requirements of the Environmental Control Officer (ECO), but will be managed by the ECO directly.

#### **4.2 Implementation of the Project Specific Occupational Health and Safety Specifications (PSHSS)**

The project specific H&S specification (PSHSS) forms an integral part of the Contract, and PCs are required to make it an integral part of their Contracts with Contractors and Suppliers. A PSHSS will be available for each level of Contract and Contractor, and must be complied with.

This specification must be read in conjunction with the OHSA, Regulations (as amended) and any other standards relating to work being done, and ensure compliance thereto. The information relative to the scope of the project, the works etc. are detailed in the tender, are to be considered when developing the H&S plan and associated documentation.

The OHSA S.37.2 Mandatary Agreement must be fully completed by the PC, supplied by the Client. These documents shall be deemed to form part of the returnable Contract Documents.

No work may commence without written approval of the H&S plan by the H&S Agent, or the responsible person in the Harry Gwala District Municipality.

Should there be design changes, or change in the scope of works, an amended PSHSS may be issued. Where amended PSHSSs are issued, the PC will be required to ensure a resubmission of an amended H&S plan for approval. Further to this, the PC must ensure that similar information must be provided as it applies to the works to all their Contractors, within 5 working days following notification thereof. The H&S Agent will visit the project as deemed necessary by the Designer and the H&S Agent to ensure compliance and limit risk. All activities on the site and all appropriate documentation will be monitored and reported on to the Client and the Designer.

Non-conformances will be issued and penalties or work stoppage will be issued where appropriate. Communication between the H&S Agent and the PC will be through the Designer (or Client's responsible person) as determined at the commencement of the project.

#### **4.3 Requirements at Tender Stage**

Tenderers are required to submit a pre-tender H&S plan with their Tender submission.

The documentation submitted will be used to assess the competence of the tenderer, as required in the CRs, therefore the information submitted needs to be complete and as close as possible to the final product.

Adequate pricing for H&S is required, and the appropriate section in the BoQ is to be completed. Failure to do so could result in the Tender being regarded as non-responsive.

The PC shall ensure adequate information is submitted as supporting documentation with his completed Tender. Such information will be assessed against the criteria listed and a score provided to the Bid Award Committee (BAC) for consideration. Failure to provide such information could render the tender application non-responsive.

A project specific H&S Plan in response to this PSHSS will be subject to approval by the H&S Agent. This must include all supporting documentation as required to verify the H&S system:

- A declaration to the effect that he has the competence and necessary resources to carry out the work safely in compliance with the Occupational Health and Safety Act and its Regulations;

- A valid Letter of Good Standing;
- Detailed technical method statements for approval by the Designer and appropriate risk assessments and safe work procedures for approval by the H&S Agent or Client:
  - Site establishment including:
    - Clearing and grubbing;
    - Exposure of services, power, telecommunication etc.;
    - Arrangements for hoarding, traffic accommodation;
  - Excavating
  - An emergency plan indicating how and where emergencies will be handled
  - Working at heights
  - Appointments of the following: Construction Supervisor; Construction Health and Safety Officer; Risk Assessor: Fall Protection Plan Developer; First Aider.
  - An organogram of the site relationships showing at least the above appointments

Further method statements are to be submitted prior to, and during the project where changes or new work is required, and the approval of the Designer/Client is required before work on that aspect or activity can commence. The H&S Officer is to be included in production planning sessions/meetings to ensure that the appropriate risk assessments, safe work procedures and communication required are available and completed timeously. Penalties will be applied should this not be adhered to, and deemed a serious offence.

## 5. GENERAL REQUIREMENTS

### 5.1 Summary of Risks identified during Design

The intention of the summary of findings from the design risk assessment is to highlight the residual risks identified during the design phase. The summary of risks provided is to point the contractor towards some risks he may not be aware of during tendering stage and while developing his formal risk assessments for the project.

The design risks and the management thereof should be included in the Principal Contractors (PC) risk assessments. Where there are other Contractors appointed to do work, the PC is to ensure that Contractors include such information in their risk assessments.

The Contractor is herein advised that no other residual risks remain which the designers judged as significant and unusual other than those risks that a competent Contractor can reasonably be expected to know or deduce from the documents prepared for this project and supplied to them.

### 5.2 Specified Hazardous Chemical Substances

The following lists of products or substances are those which have been identified as likely to be used on the project. This list is not inclusive and other products may be considered. Where the PC is likely to supply the product as the product has not been specified, material safety data sheets (MSDSs) need to be considered prior to all selections.

PRODUCTS or SUBSTANCES	POTENTIAL HEALTH OR OTHER RISKS
Cement	<ul style="list-style-type: none"> <li>• Hand mixing may occur, 50kg bags are an ergonomic risk from handling.</li> <li>• Pumping of concrete may produce extensive vibration, extended hours of work, and potential eye, skin and respiratory irritant from dust exposure, chromates.</li> </ul>

<b>PRODUCTS or SUBSTANCES</b>	<b>POTENTIAL HEALTH OR OTHER RISKS</b>
Cement/Silica dust	Caused by cutting, grinding, sanding of any concrete/granite/tiled surface/masonry resulting in occupational respiratory health illness or disease
Petrol/diesel/lubricants	Potentially a fuel bowzer on site. Fire, spillage, fumes
Adhesives	Used as a bonding agent and may result in contact Dermatitis and occupational respiratory illness or disease from prolonged exposure
Plaster/mortar/screeds	Contact with products may result in Dermatitis and occupational respiratory illness or disease from prolonged exposure
Sealants/joint fillers	Contact with products may result in Dermatitis and occupational respiratory illness or disease from prolonged exposure
Welding fumes	Inhalation of fumes may result in occupational respiratory illness or disease from prolonged exposure
Lime	The product is classified an irritant, irritating the respiratory system, skin and risk of serious damage to eyes. In contrast to the powder itself, the product, when diluted with water, can produce severe skin damage in humans, ( <i>alkaline burns</i> ), especially if prolonged skin contacts takes place.
Paints	Contact with different paints may result in Dermatitis and occupational respiratory illness or disease from prolonged exposure

## **6. OCCUPATIONAL HEALTH & SAFETY MANAGEMENT**

### **6.1 Structure and Organization of H&S Responsibilities**

#### **6.1.1 Notification of Commencement of Construction Work**

The Client shall notify the Provincial Director of the Department of Labour (DoL) in writing, in the form of the Annexure 1 in the CRs for all projects requiring a work permit in terms of CR 3.

The PC who intends to carry out any construction work other than work noted in CR 3 shall notify the Provincial Director in writing in the form of the Annexure 2. This shall occur after the award of the contract, but before commencement of construction work. Proof of submission and/or receipt must be provided and kept in the H&S file. Work will not commence without the Notification being correctly completed and signed by the Client and proof of receipt by the Department of labour received. The Notification shall only be signed by the Client following the approval in writing by the H&S Agent, or the Client.

Where changes to the conditions given in the submission are required (i.e. Contractors, completion dates, increase in workers), a revised Annexure 1/2 must be submitted to the Department of Labour. The completion date is to include the defect and liability period. A copy of the notification form and any further submissions/correspondence must be kept in the H&S file.

#### **6.1.2 Health and Safety Plan Framework**

The H&S aspects related to the project outlined in the previous sections are to be taken into account when drawing up the H&S Plan. The PC is required to demonstrate competence by providing an H&S system that will address the requirements of the project.

The current legislative requirements, SANS codes and any other standards that may guide practice are to be taken into consideration. The following aspects must be addressed in the H&S Plan as they play a role in reducing the overall risk of a particular activity, or section of the project. The H&S Agent may from time to time request additions or systems as they relate to the works or legislative requirements at the time.

The PC is to prepare a site layout drawing to indicate at least the following:

- The positions of site offices of all Contractors, toilets, drinking water and worker rest areas;
- Indicate the positions of emergency personnel and equipment (fire, first aiders, first aid posts);
- Protection of plant and pedestrians, indicate parking, and
- Storage areas (materials and equipment, waste etc.)
- Access and egress to site for deliveries and intended temporary traffic management
- Emergency assembly point

Such layouts are to be updated regularly throughout the project.

### **6.1.3 Appointment of Competent Site Personnel**

The CEO (OHSA S16.1) of the PC will take overall responsibility for the appointment of competent site staff for the duration of the project. Should the CEO not be personally involved in the project, the H&S responsibilities are to be delegated to the Contract Manager (OHSA 16.2). Knowledge and training in H&S is required, and certificates indicating H&S training as well as experience to be included in CVs.

All other legal appointments are to be made with relevance to the type of work required and kept current with the project programme. The construction team is to ensure the appointed H&S Officer is kept up to date with all planned activities, to ensure all H&S requirements are met.

All construction/technical method statements are to be generated by senior site personnel, and the appropriate risk assessments developed therefrom in conjunction with the H&S Officer.

The Occupational Health and Safety Plan shall include the following, but is not limited to the following key appointments:

### **6.1.4 Construction Supervision**

Competent supervisors will be appointed to manage part or all of the works and have training and/or experience in the area of responsibility. All site supervisors must show evidence of appropriate training in H&S, and an understanding or training in areas of responsibility (i.e. risk assessments, method statements etc.).

Curriculum Vitae (CVs) are to be submitted for approval by the Designer, and/or Client. The Supervisor will be held responsible for the safety of working teams and subordinates, housekeeping and stacking and storage of materials.

### **6.1.5 Construction Health and Safety Officer**

The PC will employ at least one competent, full-time or part time H&S Officer for the duration of the contract depending on the nature of the hazards on site and subsequent risks. The H&S Officer's CV is to be submitted for approval by the H&S Agent or the Client, at time of tender. The PC is to ensure adequate resources are provided in order to undertake all responsibilities (i.e. mobile phone, computer and internet access, vehicle etc.) Qualifications shall include at least Grade 12, SAMTRAC/NEBOSH/Diploma in H&S qualifications or similar together with additional appropriate short courses (ie. Fall Protection Developer, Risk Assessor, Basic Firefighting and First Aider Level 1) with exposure to civil engineering and building that is appropriate given the

level of project complexity and registration with SACPCMP. An in-depth knowledge of legislative requirements and the application thereof is required. The site supervisor may not act as the H&S Officer.

The H&S Officer/s will be held responsible for all H&S on the project.

- Senior site staff and supervision, Contractors are to follow systems, instructions etc. given by the H&S Officer at all times;
- No new workers or Contractors may commence work without approval or following the H&S plan as submitted, and
- No inductions of Contractor staff until the H&S documentation is approved by the H&S Officer.
- The H&S Officer/s may not be removed or replaced without the approval of the H&S Agent, nor may the site be left unattended for more than 1 day without adequate, competent cover.

A monthly report of all H&S activities and incidents is required by the end of the first week of each month, or at a date agreed to by the H&S Agent/Client and the H&S Officer. An example of the monthly report is attached as an *Annexure D*.

The H&S Officer will be responsible for collating the H&S documentation at the close out of the project in electronic format. A list of the typical aspects that should be provided is available as *Annexure B* to this document. The PC is to ensure that all Contractors documentation follows the same requirements and closed out H&S documentation must be completed and be available with the close out of the main contract.

Failure to do so will be considered a serious offence and penalties applied.

#### **6.1.6 Traffic Safety**

The H&S Officer will be responsible for ensuring that daily traffic management is adequately managed and additional care must be taken where workers and public interface.

No worker may be transported in, or on the rear of construction vehicles (bakkies included), or with plant and materials to, on, or from site. The number of passengers in any vehicle is limited to what is stated on the license disc. Vehicles used to transport workers to, from, or on site, shall have secure seats and be covered. No canopies may be used.

Tenderers must indicate in their OHS plans what type of transport is envisaged and how this will be managed.

Penalties will be issued for non-compliances noted.

#### **6.1.7 Health and Safety Representatives and H&S meetings**

H&S Representatives representing workers and Contractors are to be appointed following the startup of the project, irrespective of the number of workers on site. The appointed H&S Representatives are to be actively involved with H&S and will assist the H&S Officer and site management in meeting legislative duties.

The H&S Officer shall further ensure that H&S is discussed at all internal production or progress meetings. Issues arising from the H&S Agent audits are to be discussed, as well as all H&S related issues.

Minutes are to be kept for all H&S interventions and meetings. Failure to do so will be deemed to be a moderate offence.

### 6.1.8 Appointment of Competent Contractors

The Principal Contractor is to ensure compliance with the Clients minimum standards and all legislative requirements. The same H&S standards required of the PC are to be applied to all Contractors. An index of all Contractors and Suppliers is to be on file and kept updated at all times. The PC is to ensure there is sufficient funding for H&S compliance by each Contractor.

The following minimum aspects are applicable to any Contractor appointed:

- The H&S Officer is to ensure a Contractors appointment and approval of H&S documentation at least seven (7) working days prior to commencing work.
- No Contractor may work under the PCs Compensation registration number. If required the PC may assist SMMEs with their registration with the Compensation Commissioner. However, such Contractors will not be able to commence work until proof of registration or Letter of Good Standing has been received.
- No work may commence without Mandatary agreements between parties in place.

The following aspects are applicable to Suppliers or short-term works (surveying, repairs, servicing, deliveries etc). Cognisance is to be taken of the level of risk involved and the H&S Officer is to ensure the level of H&S documentation is appropriate:

- Mandatary agreements in place
- Letter of Good Standing
- Method statements and risk assessments
- Available information relative to:
  - Load testing and registers for cranes or lifting devices
  - Medical certificates of fitness
  - Material Safety data sheets (MSDSs)

Failure to provide written approval of H&S documentation will be considered a serious offense, and could result in aspects of, or all the activities being stopped and penalties implemented.

## 7. GENERAL RISK MANAGEMENT

### 7.1 Health Risks and Medical Surveillance

The appropriate MSDSs are to be obtained for all products and used to develop the H&S documentation as they relate to the works. Many of the processes may be labour intensive and ergonomic risks are to be noted. All workers (including Contractors) are to be included in the medical surveillance programme.

Workers will be exposed to noise, dust, and physical risks from extended periods of work of a repetitive nature, materials specified and the general nature of the works.

All workers (including those of Contractors) are required to be in possession of a medical certificate of fitness prior to commencing work.

Full medical records are not to be placed in the H&S file. Given the potential health risks the following aspects are to be included in each medical surveillance intervention:

- Full medical, surgical and occupational history;
- Full physical examination of all systems; and
- Referral if required for the management of identified health issues that may affect the worker.

Specific testing for existing conditions and limitations relative to exposure could include, but are not limited to:

- Audiometry (hearing tests); and



- Any other tests identified as relevant from chemical or specifically identified risks of exposure

Failure to do so will be considered a serious offence.

## 7.2 Noise Risks

All plant from plant hire companies (suppliers) or that of the PC is to be compliant with the Noise Induced Hearing Loss Regulations. Plant identified that has not been tested and marked for noise emissions will result in having to be tested at the Contractors or PCs expense. Failure to do so within a reasonable time period will result in such plant being removed from site.

Audiometric testing of all workers is noted as required in the medical surveillance programme for all permanent workers prior to work commencing. Temporary labour working in identified noise areas will require testing if the noise levels are indicated on plant or through processes as greater than 85dB. Audiometry records are to be available in the H&S file.

Suitable SANS approved hearing protective equipment shall be issued and worn where noise levels are identified as equal to or greater than 85dB.

Failure to do so will be considered a serious offence.

## 7.3 Emergency Procedures

A simple emergency plan and procedure that is appropriate to the risks is required prior to commencement on site. It is advised that the system should be simple and easy for any worker to follow. The plan may be adapted should new information or risks are identified.

The procedure shall detail the response plan in relation to the works, and include at least (*but are not limited to*) the following key elements:

- Appointment of a competent emergency response co-ordinator
  - Site Camp Fire;
  - Public injury, Motor vehicle accidents;
  - Falls from heights;
  - Serious injury to workers (medical or work-related); and
  - Any other major risks identified during risk assessments

The emergency plan is to ensure the inclusion of local service providers where possible. Such arrangements should be made with these persons prior to the commencement of the project. The general principals of emergency management are to be applied as it applies to the hierarchy of control and management.

## 7.4 First Aiders and First Aid Equipment

At least 1 first aider will be trained to Level 3. First aiders shall be available and accessible on site at all times, and be able to work as a team when responding to any emergency on the project.

Contractors are expected to ensure compliance and provide/manage their own first aiders and equipment. The number of First aiders will be determined by the complexity and exposed risks of the project, not numbers of workers

Appropriately stocked first aid kits are to be available at all times and to assure continual availability and access on site.

## 7.5 Fires and Emergency Management

The emergency plan is to include the risk of fire on site and related to any specific activities where gas, welding, cutting etc. occur.

Fire extinguishers will be appropriate for the risk and in sufficient numbers to deal with the type of fires that could occur. All mobile plant is to have fire extinguishers. Hot work permits are required for any such activities.

## 7.6 Incident Management and Compensation Claims

All incidents and accidents are to be investigated. All serious incidents involving any form of disabling injury or fatality are to be reported to the Designer /Client /H&S Agent immediately. This shall be confirmed in writing following the incident. Full details are to be included in each site meeting or when the Client visits site. A summary of incidents is to be included in the monthly report.

Failure to comply with emergency provisions will be considered a serious offence, and the operation or project may be stopped if deemed inadequate for the work at the time of assessment or site inspection.

## 7.7 Personal Protective Equipment (PPE) and Clothing

The PC is to provide a procedure as an addendum to indicate how PPE is managed within the Company.

The wearing of the identified SANS approved PPE at all times is non-negotiable. The PC shall ensure that all workers (Including Contractors) are issued with and shall wear:

- Hard hats;
- Protective footwear;
- Overalls that ensure worker visibility;
- Eye protection;
- Hearing protection;
- Reflective jackets (no bibs)
- Respiratory protection (minimum of FF2), and
- Any other necessary PPE identified from MSDSs and/or risk assessments.

Adequate quantities of PPE shall be available. This shall include necessary PPE for visitors. The procedure for managing PPE is to be in a formal procedure submitted with the H&S plan for approval.

Any person (*including Client, Designers etc.*) found on site without the necessary PPE will be removed from site until the PPE is supplied and worn.

Failure to comply will result in penalties being applied.

## 7.8 Occupational Health and Safety Signage

On-site H&S signage is required. Signage shall be posted up at fixed or temporary working areas, or other potential risk areas/operations. These signs shall be in accordance with the requirements of the General Safety Regulations or SANS requirements as amended. Signage is to be noted on the site drawings indicating where fixed/temporary signage is required.

Temporary signage is to include (*but not be limited to*) the following:

- 'Report to site office' / 'Warning: Construction Site – Keep out' or similar;
- 'Site office' (if relevant);
- 'hard hat area' or other PPE requirements noted;



- First aid box positions (*including vehicles*); and
- Fire extinguishers.

Signs shall be posted at areas of work on site indicating that a construction site is being entered and that persons should take note of H&S requirements.

Failure to comply will result in penalties being applied.

### **7.9 Induction of Employees and Visitors, General H&S Training**

A simple, formal induction programme is to be submitted as an addendum for approval with the H&S plan. Inductions must be carried out for all workers and visitors (*including Client, Designers*) to the site.

Pre-task training is required to ensure workers are familiar with the risks and H&S measures of the work or tasks to be done. Such training is to be done at least daily. A record of inductions and pre-task training is to be kept in the H&S file.

Any person found on site without proof of induction will be removed from site until the proof is supplied and, a penalty issued per non-compliance.

### **7.10 Management of Plant and Equipment**

Close control of plant and equipment is required, including that of Contractors.

Daily monitoring of all plant and equipment is required prior to commencing work. Full lists of hired and own plant are to be available at the H&S Agent's/Client audit. All daily inspection records are to be kept in the H&S file or Contractors where plant and equipment is brought onto site. Registers are not to be more than 1 week behind.

Only competent, medically fit plant operators are to be used. Medical certificates of fitness are required for all operators. Any plant or slings used to lift plant or material require annual load testing by an AIA, and all certificates must have the testers LMI/E number. Operators are to be adequately trained and certified to operate mobile cranes or crane trucks. Certificates and registers are to be placed in the H&S file.

Failure to do so will be considered a serious offence.

### **7.11 Excavations**

A procedure for managing excavations is to be provided as an addendum to the H&S plan describing how excavations are to be managed.

Excavation method statements are to be approved by the Designer and associated risk assessments are required. Designs by competent persons are required where ground conditions are deemed to require shoring.

A competent person is to be appointed for managing all excavations. A permit system is to be available and used for all excavations. All equipment and ground conditions are to be checked daily and prior to work commencing.

Excavations should preferably not be open beyond what can be closed daily. Where excavations need to remain open, all excavations are to be properly protected. Adequate stakes with 1m high demarcation and berms/spoil are required to be a safe distance from the edge of the angle of repose. Danger tape may not be used to demarcate excavations. Cognisance is required of the surrounding area and increased levels of protection are required where work is in the vicinity of members of the public.

Work will be stopped and penalties applied to any work in excavations that is not compliant.

### **7.12 Working at heights**

A Fall Protection Plan (FPP) is to be available and supplied as an addendum to the H&S plan. The FPP must be appropriate for the project. Method statements, appropriate risk assessments, safe work procedures and training are to be available prior to work commencing.

Construction drawings shall be required for all temporary structures as they relate to the project. The drawings shall be accompanied by full calculations, design loads and any relevant test results as required by the SANS code, and ensure adequate allowance for the development of appropriate documentation and training. All drawings are to be checked and signed by a competent structural engineer (registered with ECSA).

The focus for working at height shall include fall restraint systems where possible except during assembling or dismantling top components or where it is not deemed safe. The relevant SANS codes are to be applied as they apply to the works and the project, such as:

- SANS 10085
- SANS 50355
- SANS 50361
- SANS 50355

Should part of the works be contracted out, competent Contractors are to be appointed and submit documentation according to the project requirements. The PC is to note if such work is to be contracted to specialists in the H&S Plan. The plan is to be developed by and work managed by a competent person for the duration of the project. The following aspects must be included:

- The public are to be protected at all times by way of hoarding, barricading or fencing
- Notices to be posted
- Restrictions or stoppage when weather conditions are deemed hazardous
- Permit system for working at heights
- Prevention of falling tools or equipment
- Link to emergency plan regarding rescue
- All workers are to be in possession of valid certificates of fitness that extend for the duration of the works. Note the requirements in the section relating to medical surveillance.
- Registers and all relevant documentation are to be placed in the H&S file.

Work will be stopped and penalties applied to any work at heights that is not compliant.

### **7.13 Cranes and lifting equipment**

Should any form of lifting device or crane (fixed or mobile) be used during the project for deliveries, moving of supplies or equipment, the appropriate documentation must be made available. Method statements, risk assessments, safe work procedures and training are to be available prior to work commencing. A procedure for managing loads and lifting must be made available as an addendum to the H&S Plan.

### **7.14 Temporary Works (Scaffolding, support work, formwork)**

Temporary works must be properly designed and signed off by a competent person who has sufficient experience in the design of the type of temporary work in question to be able to assess the design. The appropriate competent persons are to be appointed to manage and monitor such works to the satisfaction of the Engineer and H&S Agent. Records and registers are to be properly completed and kept in the H&S file. If temporary works are to be erected by a Contractor, this must be notified to the Designer/H&S Agent.

Failure to do so will be considered a serious offence.

#### **7.15 Auditing**

Frequency of external auditing by the H&S Agent or Client will be as agreed with the Client and Designer but will at least conform to the requirements of the Construction Regulations. The site will be inspected and the documentation audited relative to the activities and H&S plan. The H&S Officer of the PC must accompany the Client, or the H&S Agent, on all audits and inspections. Not all audits will be, or need be announced.

The PC will ensure that all their Contractors are audited at a frequency determined by the H&S Agent or Client. Audit frequency may be increased if Contractors are not performing adequately. Audit results will be acted upon and non-conformances and penalties issued where deemed appropriate. The Client, Designer or H&S Agent may act or require further outcomes if non-compliances are noted or unsafe acts are noted on site.

Internal audits are to include site conditions as well as ensuring H&S files are appropriate, and compliant. Comprehensive audit reports are to be made available, the format of the audit reports are to be acceptable by the H&S Agent.

The PC will be audited using a template as supplied in the tender document. The audit template will be adjusted from time to time relative to the activities on site. A similar process is to be used by the PC when auditing their Contractors on site. Compliance with legislative requirements and the systems provided by the PC to manage the H&S on site will be measured. Full compliance is required. Time limits for corrective actions will be set and must be adhered to.

Failure to address findings or non-conformances will be considered a serious offence.

#### **7.16 Mechanical installations**

All mechanical installations are to be carried out in conformity with the manufacturer's instructions. Method statements and risk analyses must be compiled for each type of installation. A competent person must be designated to supervise the work.

#### **7.17 Communication on Site**

All H&S communication during the project between the H&S Agent and the PC will be done through the Engineering Consultant and be in writing, including the issue and responses to non-conformances and H&S audit results.

Failure to address issues timeously will be considered a serious offence.

#### **7.18 Care of Workers on Site (Welfare)**

Adequate toilets, clean, safe drinking water and decent shelter will be afforded workers at all times. Toilets will be within reasonable distance of workers, or placed with each working team in safe, with reasonable privacy. Hand washing facilities will be provided. Arrangements made where existing facilities are shared with existing users must be made in writing and placed in the H&S file.

Failure to ensure compliance will be considered a serious offence.

#### **7.19 Discipline, Alcohol and Substance Abuse**

All employees (management included) are to follow instructions given in the interest of H&S. A disciplinary procedure is to be developed and disciplinary action is to be imposed on those who do not follow such instructions or company rules or policies.

No person is allowed to work or access site if under the influence of alcohol or other substances that could impact on their own or others safety. The PC is to have a drug and alcohol policy available to manage such instances.

These requirements are applicable to any employee of any organization providing services on site. Penalties may also be applied by the Client, OHS Agent or Engineer.

#### **7.20 Electrical Equipment**

In addition to the requirements of the Electrical Machinery Regulations and the General Machinery Regulations any electrical distribution board used for construction work shall be fitted with suitable earth leakage protection. Leads must be properly and firmly connected. Plugs and sockets shall be in good and safe condition.

All electrical apparatus, other than electrical hand tools, shall have a physical "lock out" system which will prevent any operation other than that authorized by a supervisor. A "lock out" sign shall be displayed when the apparatus is not in use. Method statements and safe work procedures will be required for all work involving electrical apparatus.

#### **7.21 HIV and AIDS Programme**

The PC shall reduce the risk of transfer of HIV between and amongst construction workers and the local community, raise awareness amongst construction workers of the risk of infection with HIV, promote early diagnosis and assist affected individuals to access care and counselling by:-

- making condoms that comply with the requirements of SANS 4074 available for the duration of the contract to all construction workers at points on the site which are readily accessible and suitably protected from the elements
- either by placing and maintaining HIV/AIDS awareness posters of the size not less than an A1 in areas which are highly trafficked by construction workers or providing construction workers with a pamphlet in languages largely understood by the construction workers which reinforces the outcomes of the HIV/AIDS awareness programme
- encouraging voluntary HIV/STI testing
- providing information concerning counselling, support care of those that are affected

#### **7.22 Safety Conflict**

Where any conflict exists between the requirements of this PSHSS, the Site Rules or Statutory Requirements/Regulations the higher standard must apply unless such conflict is brought to the attention of the Client or H&S Agent and a direction provided. The PC is deemed to have allowed for the higher standard.

The PC is legally responsible for ensuring that he conforms to all applicable aspects of the Occupational Health and Safety Act 85/1993 and Regulations (OH&S Act) and other relevant Acts and Regulations. If in dispute with the PSHSS and other legislation the most stringent requirement must apply.

## 8. HEALTH AND SAFETY FILE

The documentation submitted and approved following the awarding of the contract will be used to form the H&S file. The H&S file is required to be laid out in a logical manner, and documentation filed within the file is to be easily accessible.

The following completed information shall be included (*but not be limited to*) as part of the index:

- The PSHSS;
- The H&S Plan and the approval by Client;
- Appointment by Client;
- Mandatary agreement with Client;
- Notification of construction work;
- A record of all working drawings, calculations and design where applicable;
- Detailed list of Contractors with contact details, appointments, Mandatories etc., H&S specifications issued;
- Record of Competencies (CVs) and appointments;
- Training Records;
- Permits;
- Method statements;
- Risk assessments;
- Safe work procedures;
- Emergency and injury management;
- Material Safety data sheets
- Medical surveillance records;
- Registers; and
- Records of audits, minutes etc.
- Plant lists
- Temporary electrical installations
- Employee records (*who is on site*)

## 9. NON-CONFORMANCES

Should, at any time, the works, or part of the works, be stopped due to unsafe acts or non-compliance with the Clients or PCs H&S Plan; neither the PC nor any other Contractor shall have a claim for extension of time or any other compensation.

The following constitute examples of the types of non-conformances that will attract penalties:

<b>Minor: Penalty: R50/count</b>	<b>Medium: Penalty: R500/count and a non-conformance</b>	<b>Severe Penalty: R5000/count, a non-conformance and/or activity stoppage</b>
Non-use of PPE supplied	Toilets not supplied or regularly serviced; lack of drinking water	Contractors working without Health and Safety Plan approval
Non completion of registers for plant and equipment on site	Contractors not audited	Workers transported in contravention of the OHS plan or legal requirements
Lack of H&S signage at work areas	Working without training or the appropriate, approved H&S method statements	Invalid Letters of Good Standing
Tools and equipment identified in poor condition during inspections	Legal non-conformances identified during the previous audit and not addressed within the agreed time frame	Non-compliance with traffic accommodation requirements: layout or physical conditions

Page SW100

<b>Minor: Penalty: R50/count</b>	<b>Medium: Penalty: R500/count and a non-conformance</b>	<b>Severe Penalty: R5000/count, a non-conformance and/or activity stoppage</b>
	No monthly OHS report at site meeting to report on	Any serious breach of legal requirements
	No certificates of fitness for workers as required	
	Working without approved method statements	

### 9.1 Failure to Comply with Provisions

Failure or refusal on the part of the PC or their Contractors to take the necessary steps to ensure the safety of workers and the general public in accordance with these specifications or as required by statutory authorities or ordered by the Principal Agent (PA), shall be sufficient cause for the PA to apply penalties as follows:

- (i) A penalty as shown in the Table above shall be deducted for each and every occurrence of non-compliance with any of the requirements of the PSHSS.
- (ii) In addition a time-related penalty of R500,00 per hour over and above the fixed penalty may be deducted for non-compliance to rectify any non-conformance within the allowable time after a site instruction to this effect has been given by the PA. The site instruction shall state the agreed time, which shall be the time in hours for reinstatement of the defects. Should the Contractor fail to adhere to this instruction, the time-related penalty shall be applied from the time the instruction was given.

## 10. MEASUREMENT AND PAYMENT

The payment items for Occupational Health & Safety are contained in the Bill of Quantities. The same rules are applicable in respect of the pricing of these items as for every other payment item. Attention is drawn to the Pricing Instructions in this document.

### Item and Unit

#### **C.01 Preparation of Contractor's Project Specific Health and Safety Plan. (Lump Sum (L.S))**

The rate for this item must cover all expenses incurred in preparing the Contractor's project specific Health and Safety Plan as required by the Client's project specific Health and Safety Specification in this document.

#### **C.02 Principal Contractor's initial obligations in respect of the Occupational Health and Safety Act and Construction Regulations. (Lump Sum (L.S))**

The full amount will be paid in one instalment only when the Client's Agent has verified and approved the following

- (a) The Principal Contractor has notified the Provincial Director of the Department of Labour in writing of the project, Annexure 2 to the Regulations.
- (b) The Principal Contractor has made the required initial Appointments of Employees and Contractors.
- (c) The Client has approved the Principal Contractor's project Health and Safety Plan.
- (d) The Principal Contractor has set up his Health and Safety File.

**C.03 Principal Contractor's time related obligations in respect of the Occupational Health and Safety Act and Construction Regulations. (Month (Mth))**

The amount shall represent full compensation for that part of the Principal Contractor's general obligations in terms of the Occupational Health and Safety Act and Regulations which are mainly a function of time. Payment will be made when the Client's Agent has verified the Principle Contractor's compliance as part of the audit. This will include the updating and administration of the Health and Safety file.

**C.04 Provision of Personal Protective Equipment (PPE) as listed in the Bill of Quantities. (Number (No))**

The rates for these items shall include for the procurement, delivery, storage, distribution and all other actions required for the supply of PPE to the employees of the Principle Contractor, full or part time, requiring them. Sub-Contractors are responsible for their own costs in this regard. Any items of PPE not included on the list will be paid for only after the PA has agreed to their acquisition.

Items listed will include, among others which may be noted, are: hard hats, reflective vests, high visibility overalls, protective foot wear, fall arrestor harness, gloves, ear muffs, earplugs and dust masks of appropriate type. Normal items such as standard overalls, waterproof clothing, gum boots and standard workshop safety equipment such as welding masks and goggles will not be paid for.

Payment will be based on the issues register for PPE as kept by the Construction Health and Safety Officer, backed up by paid invoices if requested.

**C.05 Provision of a Full/Part Time Construction Health and Safety Officer (Month)**

The Tender sum shall include for the cost of a Construction Health and Safety Officer on a fulltime or part time basis.

**C.06 Costs of Medical Surveillance (Unit (No))**

This item shall covers all costs in involved in the obtaining of baseline medical examinations of temporary labour, including operators for mobile plant as contemplated in CR 23(d) (ii); for temporary workers and workers exposed to noises at or above the limits given in the Noise-induced Hearing Loss regulations, as stipulated.

Workers in the permanent employ of the Contractor will only be paid for if their certificates require updating.

**C.06 a)** Initial (baseline) medical examinations, including audiometric and lung function testing.

**C.07 Induction Training (Unit (No))**

This item shall cover all costs incurred for the health and safety inductions as set out in Regulation 7 of the Construction regulations and the proof of induction required. Payment will be made on the figures contained in the induction section of the Health and Safety File.

**C.08 Provision of First Aid Boxes. (Unit (No))**

The rate for this item shall cover all costs incurred in the provision and maintaining of first aid boxes.

**C.09 Establishment of noise levels (Unit (No))**



This item shall cover all costs involved in the establishment of noise zones in terms of Regulation 9 of the Noise-induced Hearing Loss Regulations. Where a zone has previously been established for a particular item of plant within the last two years, the test need not be repeated but must be kept valid for the duration of the Contract.

**C.10 Submission of the Health and Safety File. (Lump Sum)**

Expenditure under this item shall be made in accordance with the general conditions of contract.

This amount will be paid only once the Principal Contractor has met all his obligations in respect of the Occupational Health and Safety Act and the Construction Regulations and has submitted his Health and Safety File complete as envisaged on this specification to the Client's satisfaction. This must be done prior to the issue of a Certificate of Completion



# ANNEXURE A

## H&S AGENT AUDIT SHEET EXAMPLE OCCUPATIONAL HEALTH AND SAFETY AUDIT DOCUMENT

PROJECT NAME:	
CONTRACT NUMBER:	
HEALTH AND SAFETY AUDIT No:	
CONDUCTED BY :	
DATE :	

### EXECUTIVE SUMMARY

### INTRODUCTION AND OVERVIEW

#### Scoring:

The audit has a scoring schedule, which will be used to deem compliance to what is available on site, and what the appropriate systems need to be to match them. The contractor should aim for a score of 3 on each aspect included in the audit. A low score could result in part or all of the work being stopped until compliance is reached.

Scoring schedule	
If the answer is <b>"No"</b> the rating will be 0	
If the answer is <b>'not applicable'</b> it will be noted as n/a	
If the answer is <b>"Yes"</b> the following ratings are applicable	
1	Requirements partially met and no implementation.
2	Requirements partially met and partially implemented
3	Requirements fully met and partially implemented
4	Requirements fully met and fully implemented
5	Requirements and implementation exceeds expectation

#### Key Abbreviations:

Health and Safety	H&S	Driven Machinery Regulations	DMRs
Occupational Health	OH	Regulations for Hazardous Chemical Substances	RHCSs
Construction Regulations	CRs	Pressure Equipment Regulations	PERs
General Safety Regulations	GSRs	General Administration Regulations	GARs
Explosive Regulations	ERs	South African National Standards	SANS
Noise Induced Hearing Loss Regulations	NIHLs	South African Road Traffic Safety Manual	SARTSM
Facilities Regulations	FRs		
South African Bureau of Standards	SABS		
Occupational Health and Safety Act	OHSA		

Provide a summary of site inspection, significant findings of the site inspection and the audit.

HARRY GWALA DISTRICT MUNICIPALITY

CONSTRUCTION OF UMZIMKHULU BULK SEWER OUTFALL

HGDM 759/HGDM/2022

CORE LEGAL RECORDS ON SITE:

This list is not conclusive – to be updated monthly relative to works in progress. However the H&S Officer is to be pro-active and pre-empt requirements with the Construction Supervisor (Site Agent). The content will be linked to the physical conditions, processes and activities noted on site, or programme.

ITEM	Legal /SPEC Ref	RECORDS TO BE KEPT	SCORE	COMMENTS	By whom	Completion Date	Contractor Close out
1.		Updated project <b>H&amp;S Organogram</b>					
2.	OHSA S. 16 (1) and (2)	CEO and subordinate (if required) • Proof of Competency provided					
3.	CR 8 (1) and (2)	Designation of Construction Manager and Subordinate Person(s) • Proof of Competency provided					
4.	OHSA S. 17; GAR 7	• H&S Representatives appointed • Monthly inspections completed • Representation from Contractors					
5.	OHSA S. 18; GAR 5	• H&S Committee appointed • Minutes on file • H&S representatives reports discussed • Incidents discussed • Signed by Chair • Evidence of minutes noted					
6.	GAR 4	Copy of OH&S Act (Act 85 of 1993) available on site					
7.	CR 5(j); 7(c)(iv)	Written proof of registration / <b>Letters of good standing</b>					

ITEM	Legal /SPEC Ref	RECORDS TO BE KEPT	SCORE	COMMENTS	By whom	Completion Date	Contractor Close out
		available on Site					
8.	OHSA S.37.2	<b>Copy of the Mandatary (S37.2) agreement between the PC and Client</b>					
9.	OHSA S.37.2	<b>Mandatary agreements</b> between PC and contractors					
10.	CR 3(1); 4(1)	<b>Notification to Provincial Director – Annexure 1/2</b> Available on site					
11.	CR 5(1)(m)  7(1)(b)	<ul style="list-style-type: none"> <li>• Copy of Principal Contractor's Health &amp; Safety Plan Available on request.</li> <li>• Letter of approval from Agent.</li> <li>• Health &amp; Safety File opened and kept on site (including all documentation-required in respect of the OHSA &amp; Regulations)</li> <li>• Available at all times</li> </ul>					
12.	CR 7(1)(b)	<b>Copy of Principal Contractor's Health &amp; Safety File provided to Contractors</b> <ul style="list-style-type: none"> <li>• Letters of approval for each contractor on file</li> <li>• List of Contractors on site</li> <li>• Verified monthly by Agent</li> </ul>					
13.		<b>Copies of technical method statements</b> approved by Designer					

ITEM	Legal /SPEC Ref	RECORDS TO BE KEPT	SCORE	COMMENTS	By whom	Completion Date	Contractor Close out
		<ul style="list-style-type: none"> <li>Register available, signed by Designer</li> </ul>					
14.	CR 9(1)  OHS CR 9(3)	<b>Risk Assessments:</b> <ul style="list-style-type: none"> <li>Up to date and available on site for inspection</li> <li>Review and monitoring programme adhered to</li> <li>Workers trained in risk assessments</li> </ul>					
15.	CR9(1)(c)	<b>Safe work procedures Procedure</b> <ul style="list-style-type: none"> <li>List of available SWPs</li> <li>Workers trained in SWPs</li> <li>Proof of training verified</li> </ul>					
16.	OHS S. 13 CR 7(5)(6)	<b>Induction programme available</b> <ul style="list-style-type: none"> <li>Proof of <b>induction</b> training available</li> </ul>					
17.	CR 6(1)(2)	<b>Structural information from Designer:</b> <ul style="list-style-type: none"> <li>Geo-science technical report</li> <li>Design loading of the structure</li> <li>Methods &amp; sequence of construction</li> <li>Design risk assessment</li> <li>Amended H&amp;S Specification</li> <li>Temporary Works Design</li> </ul>					
18.	CR 12(1)(3)	<b>Temporary Works</b>					

ITEM	Legal /SPEC Ref	RECORDS TO BE KEPT	SCORE	COMMENTS	By whom	Completion Date	Contractor Close out
		<ul style="list-style-type: none"> <li>• Appointment of temporary works designer</li> <li>• Proof of Competency provided</li> <li>• Approved temporary works drawings</li> <li>• Temporary work inspection register</li> <li>• Competencies of erectors of temporary works</li> <li>• Construction method statements</li> </ul>					
19.	CR 13(1)(2)	<b>Excavations:</b> <ul style="list-style-type: none"> <li>• Competent persons appointed</li> <li>• CVs available</li> <li>• Depth of excavations on site</li> <li>• Shoring in use</li> <li>• Registers in line with open excavations noted at site inspection</li> </ul>					
20.	CR 13(f) GSR 13A	<b>Ladders:</b> <ul style="list-style-type: none"> <li>• Competent person appointed</li> <li>• Registers kept</li> <li>• Registers for ladders noted on site</li> </ul>					
21.	CR 16(1)	<b>Scaffolding: SANS 10085</b> <ul style="list-style-type: none"> <li>• Competent Erector(s) and Inspector appointed</li> <li>• Proof of Competency provided</li> <li>• Registers in place</li> </ul>					
22.	CR 23	<b>Construction Vehicles:</b>					

ITEM	Legal /SPEC Ref	RECORDS TO BE KEPT	SCORE	COMMENTS	By whom	Completion Date	Contractor Close out
		<ul style="list-style-type: none"> <li>• Appointment of competent operators</li> <li>• Plant Management:</li> <li>• Registers on file noting daily inspections</li> <li>• Plant and machine lists available</li> <li>• Inadequacies noted on site</li> <li>• Transportation of workers</li> <li>• Registers for sample of vehicles noted on site</li> </ul>					
23.	CR 24	<b>Temporary Electrical Installations and Machinery</b> <ul style="list-style-type: none"> <li>• Competent Person appointed</li> <li>• Proof of Competency provided</li> <li>• Updated weekly installation inspection registers in place</li> <li>• Updated daily inspection registers in place</li> </ul>					
24.	CR 25	<b>Flammable Liquids:</b> <ul style="list-style-type: none"> <li>• Competent Person appointed for inspections</li> <li>• Proof of Competency provided</li> <li>• Inspection registers in place</li> </ul>					
25.	CR 27, ER 6 GSR 8	<b>Housekeeping, Stacking &amp; Storage Supervisor:</b> <ul style="list-style-type: none"> <li>• Appointed per work area</li> <li>• Proof of Competency provided</li> <li>• Include site conditions</li> <li>• Spoil areas</li> <li>• Register available per area</li> </ul>					

ITEM	Legal /SPEC Ref	RECORDS TO BE KEPT	SCORE	COMMENTS	By whom	Completion Date	Contractor Close out
26.	GSR 2	<b>PPE:</b> <ul style="list-style-type: none"> <li>• included in Risk Assessment</li> <li>• PPE used and enforced</li> <li>• Records of Issue kept</li> <li>• Training to use (Induction)</li> <li>• Registers for condition checks</li> </ul>					
27.	RHCSs CR 7; 23 GSR 4	<b>Hazardous Chemical Use and Storage</b> <ul style="list-style-type: none"> <li>• Competent Person/s appointed</li> <li>• Proof of Competency provided</li> <li>• Risk Assessments include use of HCSs</li> <li>• Register of HCS kept/used on Site</li> <li>• Flammable Store</li> <li>• Bulk diesel storage</li> <li>• Material Safety Data Sheets on file and utilised</li> <li>• Other</li> </ul>					
28.	GSR 3	<b>Emergency management:</b> <ul style="list-style-type: none"> <li>• First aiders available through project</li> <li>• Level 1</li> <li>• First aid boxes through site</li> <li>• Evacuation procedures</li> <li>• Registers available (noted on site)</li> </ul>					
29.	GAR	<b>Incident Management:</b> <ul style="list-style-type: none"> <li>• Emergency co-ordinator appointed</li> </ul>					

ITEM	Legal /SPEC Ref	RECORDS TO BE KEPT	SCORE	COMMENTS	By whom	Completion Date	Contractor Close out
		<ul style="list-style-type: none"> <li>• Proof of Competency provided</li> <li>• Emergency plan appropriate</li> <li>• Emergency level included in Risk Assessments</li> <li>• Workers trained</li> <li>• Incident reports available and complete</li> </ul>					
30.	CR 1 (g), 7(8)	<b>Medical Surveillance Programme</b> <ul style="list-style-type: none"> <li>• All employee records</li> </ul>					
31.	CR 30/ FRs	<b>Welfare Facilities:</b> <ul style="list-style-type: none"> <li>• Toilets available where crews are working/clean</li> <li>• Clean potable water available</li> <li>• Adequate eating facilities</li> </ul>					
32.	SANS 1921-6	<b>HIV AND AIDS PROGRAMME</b> <ul style="list-style-type: none"> <li>• HIV and AIDS Policy and plan available</li> <li>• Condoms available</li> <li>• Peer review programme available</li> <li>• Ongoing training of workers</li> </ul>					
29.		<b>Other</b>					



<b>RESPONSIBILITY</b>	<b>SIGNATURE</b>	<b>DATE</b>
<b>H&amp;S AGENT SIGNATURE:</b>		
<b>PC SIGNATURE:</b>		
<b>DESIGNER SIGNATURE:</b>		
<b>CLIENT SIGNATURE:</b>		

# ANNEXURE B

## CLOSE OUT REQUIREMENTS

The H&S files for the Principal Contractors and all Contractors require closure and handover to the Client at the completion of the project. The following list is an example of what should be included, but is not exhaustive. The OHS Agent or the Client may require further information at the time of completion and the Principal Contractor is to ensure that all instructions are met. Documentation would include all records from the start of the project. Daily or monthly plant inspection records are not required unless they are related to an accident. All records to be in electronic format and submitted to the OHS agent for approval in adequately formatted lists and folders. Layout should be logical and in the same order as in the site files.

**Health and Safety close out file requirements include:**

- a) Client H&S Specification
- b) Principal Contractor's OHS Plan(s)
- c) Organograms
- d) Legal Appointments
- e) List of all employees employed on a permanent or contractual basis over the duration of the contract
- f) Notification to Department of Labour of commencement of work
- g) Letters of Good Standing for the Project
- h) Full files for all Contractors as well as their close out reports
  - List of Contractors
  - All employees employed on a permanent or contractual basis over the duration of the contract
  - Letters of Approval of Contractors
  - Mandatary Agreements
  - Letters of Good Standing
  - Appointments
- i) Incident Records
- j) Non- Conformance records
- k) Agent's Audits
- l) Method Statements
- m) Risk assessments
- n) Safe work procedures
- o) Medical surveillance certificates of fitness. Medical records are to be kept according to the OH&S Act as amended
- p) All drawings for temporary structures (suspended beams/scaffolds etc)
- q) All operating manuals for any systems that require ongoing maintenance
- r) Copies of test results, policies and procedures for environmental monitoring (silica, noise, dusts etc.)

### **Defect and Liability Period**

The H&S files are to be kept 'live' for the defect and liability period by the Principal Contractor, including those of their Contractors. Any work required during the defect and liability period will require an assessment of the H&S file by the OH&S Agent prior to any work commencing.

A copy drawing records for the as-builts are to be placed on file by the Designers once complete.

# ANNEXURE C

## NON CONFORMANCES

HEALTH AND SAFETY SITE INSPECTION NON CONFORMANCE NO		
<b>AGENT:</b>	<b>PROJECT:</b>	
<b>Consultant:</b>	<b>Date and time:</b>	
<b>Client</b>	<b>Area:</b>	
<b>Contractor:</b>		
<b>ASPECTS NOTED:</b>	<b>COMMENTS:</b>	<b>COMPLETION REQUIRED BY (DATE):</b>
	•	
	•	
	•	
	•	
	•	
<b>PHOTOGRAPHIC EVIDENCE (if available):</b>		
<b>OTHER:</b>		
The following penalties are to be applied:		
<b>Signature of Designer</b>		
<b>Signature of H&amp;S Officer/Site Agent</b>		
<b>Signature: of H&amp;S Agent</b>		

# ANNEXURE D:

**CONTRACTORS MONTHLY HEALTH AND SAFETY REPORT**  
 (To be submitted by the end of the first week of each month and be available with each audit)

CONTRACT NUMBER:		PROJECT NAME:	CONTRACT DETAILS:
1	GENERAL ACTIVITIES FOR THE MONTH  (detail each area of work)		
2	NUMBER OF WORKERS (permanent and local, contractors)		
3	TRAINING DONE (supplier, no of people, type)		
4	INCIDENTS / ACCIDENT (list number and details, attach reports)		
6	NON-CONFORMANCES (closed out or active)		
7	CONTRACTORS (list, approval status)		
8	AUDITS COMPLETED (internal and external)		
9	CRITICAL ISSUES		
10	GENERAL		

<b>H&amp;S Officer</b>	<b>Signature</b>	<b>Date:</b>
<b>Site Agent</b>	<b>Signature</b>	<b>Date:</b>

## ANNEXURE E RISK ASSESSMENT FORMAT

<b>ACTIVITY</b>		<b>RA No.</b>		<b>Rev No.</b>	
<b>CONTRACT</b>		<b>DATE WRITTEN</b>		<b>REVIEW DATE</b>	
	<b>WRITTEN BY</b>	<b>REVIEWED BY</b>		<b>APPROVED BY</b>	
<b>NAME</b>					
<b>SIGNATURE</b>					

RISK REF	ACTIVITY	POTENTIAL HAZARD	RISK	S	H	E	RISK EVALUATION	PURE RISK	CONTROLS MITIGATION	EFFECTIVENESS OF CONTROLS	RESIDUAL RISK	RESIDUAL RISK RANKING
----------	----------	------------------	------	---	---	---	-----------------	-----------	---------------------	---------------------------	---------------	-----------------------

### Severity Criteria

Weight No	Hazard Description	Environment	Safety/Health
16	Catastrophic	Irreversible ecological damage	Multiple fatalities due to injury or occupational disease
8	Major	Reversible ecological damage with potential long term impact	Fatality or number of disabilities/disabling diseases
4	Moderate	Ecological disturbance, can be rehabilitated	Disabling injury or occupational illness
2	Minor	Short-term ecological impact. Requires intervention	Minor injuries or exposure requiring medical attention
1	Insignificant	Low impact, natural rehabilitation	First Aid treatment required

### Frequency Criteria

Weight No	Hazard Description	Frequency
1	Rare	Less than once every 2 years
2	Infrequent	Every 1-5 years
3	Frequent	Multiple times per year
4	Often	Monthly
5	Consistent	Weekly/Daily

### Exposure Criteria

Weight No	Hazard Description	Environmental Exposure	Safety/Health Exposure
1	Minimal	Incident site	A few of the workforce minimal time
2	Restricted	Localised	A few of the workforce, some of the time/some of the workforce minimal time
3	Local	Construction Site Wide	Some of the workforce, some of the time
4	Widespread	Immediate neighbours	Most of the workforce, some of the time/some of the workforce most of the time
5	Extensive	Community exposure	Most of the workforce, most of the time

## ANNEXURE F:

### TYPICAL BILL OF QUANTITIES FOR OCCUPATIONAL HEALTH AND SAFETY

ITEM NO	DESCRIPTION	UNIT	QUANTITY	RATE	TOTAL
C.01	Preparation of the Contractor's site-specific Health and Safety Plan	lump sum			
C.02	Principal Contractor's initial obligations in respect of the Occupational Health and Safety Act and Construction Regulations	lump sum			
C.03	Principal Contractor's time related obligations in respect of the Occupational Health and Safety Act and Construction Regulations	month			
C.04	Provision of Personal Protective Equipment (PPE)				
	(a) Reflective vests	No			
	(b) Hard hats	No			
	(c) Protective foot wear	No			
	(d) Earplugs	No			
	(e) Dust masks	No			
	(f) Gloves				
	(h) Ear Defenders SABS approved	No			
C.05	Provision of a full time Construction Health and Safety Officer	month			
C.06	Cost of medical certificates and medical surveillance				
	(a) Initial (baseline) medical examinations	prime cost (PC) sum			

	(b) Periodic and exit examinations	prime cost (PC) sum			
	(c) Contractor's charges to allow for handling costs and profit in respect of sub items 13/X.06 (a) and (b)	%			
C.07	Induction training	No			
C.08	Provision of First Aid Boxes to GSR requirements	No			
C.09	Noise monitoring				
	(a) Establishment of noise zones (plant)	No			
	(b) Audiograms (personnel)	No			
C.10	Submission of a Health and Safety File	lump sum			

# ANNEXURE G

## HARRY GWALA DISTRICT MUNICIPALITY

### HEALTH AND SAFETY (H&S) PRE-TENDER REPORT

Tenderers are required to submit a pre-tender H&S plan with their Tender submission.

The following requirements were set in the tender documentation and have been utilized to assess the completeness of the documentation presented with the submission of tenders. These requirements fulfil the requirements of the Client in terms of the Construction Regulations, Regulation 5(1)(h). They are to be read in addition to the Act and Regulations but are not a substitute for them.

The documentation submitted will be used to assess the competence of the tenderer, as required in the CRs, therefore the information submitted needs to be complete and as close as possible to the final product.

The following scores have been used to determine compliance with the pre-tender requirements:  
Scoring as follows:

**Not supplied or not adequate**                    **0**  
**Supplied and complete**                        **1**

If the tenderer has not completed any projects then Items 4 and 5 need not be supplied. A letter to this effect must be attached.

***Tenderers are required to achieve a minimum of 10 out of a total of 17 for their tenders to be considered.***

Legal or Specification Reference	Pre-Tender Requirement H&S	Tenderers Response	Max Score	Actual Score
Construction Regulations (CRs) 7(1)	1. A project specific H&S Plan in line with this project specification which will support the CRs, therefore the information submitted needs to be complete and as close as possible to the final product. See check sheet		1	
CRs 5(1)(g)	2. Adequate pricing for H&S is also required, and the appropriate section in the BoQ is to be completed. Failure to do so could result in the Tender being regarded as non-responsive.		1	
CRs 5(1)(h)	3. A declaration to the effect that he has the competence and necessary resources to carry out the work safely in compliance with the Construction Regulations 2014;		1	
	4. At least one copy of minutes of previous Occupational Health and Safety Committee meetings;		1	



	5. Incident Investigation Reports for other projects of a similar nature undertaken by the tenderer		1	
CRs 9(1)(b)	6. Detailed technical method statements for approval by the ER and for approval by the H&S Agent:  a. Site establishment; b. Clearing and grubbing; c. Construction of offices and accommodation, and d. Proposed site layouts		1 1 1 1	
CRs 9(1)	7. Appropriate risk assessments:  a. Site establishment; b. Clearing and grubbing; c. Construction of offices and accommodation, and d. Proposed site layout		1 1 1 1	
CR 9(1)	8. Appropriate safe work procedures a. Site establishment; b. Clearing and grubbing; c. Construction of offices and accommodation, and d. Proposed site layouts		1 1 1 1	
	<b>FINAL SCORE</b>		<b>17</b>	

# ANNEXURE H

## TENDER STAGE OHS PLAN EVALUATION

Tenderers will be scored on their response to various facets of the Health and Safety Specification in the Tender Document. Failure to achieve a score of 60 % will render the tender non-responsive				
Proof of the evaluation must be given under the remarks column				
1	<b>General</b>	Is the Specification Project Specific? If not then score is 0.		
	<b>Scoring</b>	Response present and satisfactory	1	
		Not present	0	
<b>OHS Act/regulation</b>	<b>Specification Section</b>	<b>Description</b>	<b>Max Score</b>	<b>Score</b>
8(1)	6.1.4	Construction supervisor	1	
8(6)	6.1.5	Construction Health and Safety Officer	1	
	7.1	Health Risks and Medical Surveillance		
NIHLR	7.2	Noise Risks	1	
	7.3	Emergency Procedures		
GSR 3	7.4	First Aiders and First Aid Equipment	1	
CR 27	8	Fires and Emergency Management	1	
GAR 8	7.6	Incident Management and Compensation Claims	1	
GSR 2	7.7	Personal Protective Equipment (PPE) and clothing	1	
GSR 2B	7.8	Occupational Health and Safety Signage	1	
CR 7 (5)(6)	7.9	Induction of Employees and Visitors, General H&S Training	1	
CR 23	7.10	Management of plant and equipment	1	
CR13	7.11	Excavations	1	
CR 10	7.12	Working at Heights	1	
CR 8	7.12	Fall protection plan	1	
CR 24	7.13	Cranes and lifting equipment	1	
CR 12	7.15	Temporary works	1	
CR5(1)(0)	7.18	Auditing	1	
DMR/GMR	7.19	Mechanical installations	1	
OHS 8(2)(j)	7.20	Communication on Site	1	
CR 30	7.21	Care of Workers on Site (Welfare)	1	
	<b>Additional requirements</b>			
	6.1.3	Declaration of competency	1	
Cr 9 (1)		Method statements (SWPs)		
		a) Site Establishment	1	
CR5(1)(g)		Has pricing for OHS been allowed for?	1	
		<b>TOTAL SCORE</b>	24	
		<b>TOTAL PERCENTAGE</b>		

If a section is not applicable, then it must be deleted from the score sheet and the total score reduced.

# ANNEXURE I

## AGREEMENT IN TERMS SECTION 37.2 OF THE OCCUPATIONAL HEALTH AND SAFETY ACT 1993 (ACT NO. 85 OF 1993)

THIS AGREEMENT is made at \_\_\_\_\_ on this the \_\_\_\_\_ day of \_\_\_\_\_ in the year \_\_\_\_\_ between HARRY GWALA DISTRICT MUNICIPALITY (*hereinafter called "the Client"*) of the one part, herein represented by \_\_\_\_\_ in his capacity as \_\_\_\_\_ and delegate of the Client in terms of the Client's standard powers of delegation.

and

\_\_\_\_\_ (*hereinafter called "the Mandatary"*) of the other part, herein represented by

\_\_\_\_\_ in his capacity as \_\_\_\_\_

and being duly authorised by virtue of a resolution appended hereto as Annexure A.

WHEREAS the Client is desirous that certain works be constructed, viz **CONTRACT NO.** \_\_\_\_\_, and has accepted a tender by the Mandatary for the construction, completion & maintenance of such works and whereas the Client and the Mandatary have agreed to certain arrangements and procedures to be followed in order to ensure compliance by the Mandatary with the provisions of the Occupational Health and Safety Act 1993 (Act 85 of 1993 as updated);

### NOW THEREFORE THIS AGREEMENT WITNESSETH AS FOLLOWS:

- 1 The Mandatary shall execute the work in accordance with the contract documents pertaining to this contract;
- 2 This Agreement shall hold good from its commencement date, which shall be the date determined in terms of the Form of Offer and Acceptance, or other date decided upon, in the Contract Data, to either;
  - a) The date of the final certificate issued or as contained in this Volume \_\_\_\_\_ of the contract documents pertaining to this Contract, or
  - b) The date of termination of the Contract;
- 3 The Mandatary declares himself to be conversant with the following:
  - a) All the requirements, regulations and standards of the Occupational Health and Safety Act (Act 85 of 1993 as updated), hereinafter referred to as "The Act", together with its amendments and with special reference to the following Sections of The Act.
    - i. Section 8: General duties of clients to their employees;
    - ii. Section 9: General duties of clients and self-employed persons to persons other than employees;
    - iii. Section 10: General duties of manufacturers and others regarding articles and substances for use at work;
    - iv. Section 37: Acts or omissions by employees or Mandatories, and
    - v. Sub-section 37(2) relating to the purpose and meaning of this Agreement.

**Page SW122**

- b) The Contractor shall ensure that he familiarises himself with the requirements of the Clients health and safety specification developed for the project, and that he, his employees and any other Contractors employed during the project comply with them. The Contractor shall ensure that all health and safety documentation required as part of the health and safety plan is maintained for the duration of the project.
- 4 In addition to the requirements of conditions of contract (as amended by the Contract Data of the contract documents pertaining to this Contract), the Mandatary agrees to execute all the works forming part of this Contract and to operate and utilize all machinery, plant and equipment in accordance with The Act.
- 5 The Mandatary is responsible for the compliance with the Act by all his Contractors, whether or not selected and/or approved by the Client.
6. The Mandatary warrants that all his own and his Contractors' workmen are covered in terms of the Compensation for Occupational Injuries and Diseases Act 1993 as amended, which cover shall remain in force whilst any such workmen are present on site. A letter of good standing from the Compensation Commissioner to this effect must be produced to the Client upon signature of the agreement.
7. The Mandatary undertakes to ensure that he and/or subcontractors and/or their respective clients will at all times comply with the following conditions:
  - a) The Mandatary shall assume the responsibility in terms of Section 16.1 of the Occupational Health and Safety Act. The Mandatary shall not delegate any duty in terms of Section 16.2 of this Act without the prior written approval of the Client. If the Mandatary obtains such approval and delegates any duty in terms of section 16.2 a copy of such written delegation shall immediately be forwarded to the Client.
  - b) All incidents referred to in the Occupational Health and Safety Act shall be reported by the Mandatary to the Department of Labour as well as to the Client. The Client must further be provided with copies of all written documentation relating to any incident.
  - c) The Client hereby obtains an interest in the issue of any formal enquiry conducted in terms of section 32 of the Occupational Health and Safety Act into any incident involving the Mandatary and/or his employees and/or his Contractors.
  - d) The Mandatary shall conduct such risk assessments, method statements and safe work practices as may be necessary during the course of the contract and shall ensure that all staff are informed of these. Proof of this shall be placed in the project Health and Safety file.
  - e) Adherence to the Contractor's Health and Safety plan must be enforced including the application of penalties for non-conformance as set out in the Client's Health and Safety Specification.

In witness thereof the parties hereto have set their signatures hereon in the presence of the subscribing witnesses:

**SIGNED FOR AND ON BEHALF OF THE CLIENT:-** \_\_\_\_\_

**WITNESS SIGNED:-** 1. \_\_\_\_\_ 2. \_\_\_\_\_

**NAME (IN CAPITALS) 1.** \_\_\_\_\_ **2.** \_\_\_\_\_

**SIGNED FOR AND ON BEHALF OF THE MANDATARY:-** \_\_\_\_\_

**WITNESS SIGNED:-** 1. \_\_\_\_\_ 2. \_\_\_\_\_

**NAME (IN CAPITALS) 1.** \_\_\_\_\_ **2.** \_\_\_\_\_

HARRY GWALA DISTRICT MUNICIPALITY

CONSTRUCTION OF UMZIMKHULU BULK SEWER OUTFALL

HGDM 759/HGDM/2022

---

## HARRY GWALA DISTRICT MUNICIPALITY



### UMZIMKHULU BULK SEWER

CONTRACT No. HGDM 759/HGDM/2022

CONSTRUCTION OF UMZIMKHULU BULK SEWER OUTFALL

**PART C3  
ENGINEER'S QUALITY MANAGEMENT  
SPECIFICATION**

## 1. INTRODUCTION

HGDM subscribes to a Quality Management System accredited by a number of certification bodies including ISO 9001.

This document/specification summarises the Quality Control Procedures used by the Contractor in the Quality Assurance and Control on site works. These procedures are to be used by Engineer's Representative Staff (i.e. ER and his assistants) and the Contractor's staff on the following commonly encountered sites;

- Pipelines
  - uPVC Pipelines
- Concrete Works
- Masonry Works

The procedures have been developed as "intellectual" property of Harry Gwala District Municipality and may only be used on sites managed by Zimile Consulting Engineers. Any other use is subject to consent/agreement with Harry Gwala District Municipality and Zimile Consulting Engineers.

All references to approval by ER require that the Contractor (via the Site Agent) initiates the necessary request for approval). In addition, the Contractor will be required to maintain a copy of all records as required by this Specification.

The application of the procedures will be agreed as appropriate between the Contractor's Site Agent and the Engineer (or his Representative) at the commencement of construction activities.

***It will be deemed that the Contractor has incorporated in his completion period and pricing, the necessary requirements to comply with this Specification fully.***

### 1.1 Elements of Site Quality Assurance

The elements of Site Quality Assurance comprise the following:

- general elements that apply to all sites and
- site specific elements that are specific to sites and may be dependent on the type of construction.

## 2. GENERAL ELEMENTS APPLICABLE TO ALL SITES

### 2.1 Construction Quality Control Organization

This section presents the requirements of key site personnel involved on construction sites, i.e. Engineer's Representative (ER) staff and Contractor's staff. The following quality assurance procedures for site quality assurance personnel should be followed:

#### 2.1.1 Engineer's Quality Assurance Personnel

The following ER staff appointments' procedure should be followed to ensure the right superintendence on contracts:

Item	Activity	Remarks	Responsible Party	Approval by
1	Appointment of Engineer for	Stated in contract data	Engineer	Employer

## HARRY GWALA DISTRICT MUNICIPALITY

### CONSTRUCTION OF UMZIMKHULU BULK SEWER OUTFALL

HGDM 759/HGDM/2022

	contracts			
2	Supervision staffing arrangements	Proposed prior to construction work	Engineer	Employer
3	Site staff	Proposal for site personnel including CV's	Engineer	Employer
4	Roles	Delegation of powers by Engineer	Engineer	Engineer

The site staff will comprise the Engineer's Representative (ER) and ER's assistants (Field Officers):

#### (a) Engineer's Representative (ER)

The ER is the primary point of contact for the Engineer on all construction management issues. The ER will monitor and approve each contractor's quality submittal to ensure that the project is meeting the specifications and requirements. The ER will manage the implementation of the Quality Control Assurance Plan (QCAP) at the project sites with assistance from Field Officers appointed by the Engineer.

#### (b) ER Assistants/Field Officers (FO's)

Field Officers (FOs) are responsible to the ER and support the ER's management of the QCAP. The FOs will monitor the day-to-day activities of the contractor. This includes ensuring that contractors comply with the drawings and specifications, applicable SABS standards, good workmanship, and the Quality Control (QC) requirements. As part of this effort, FOs will:

- conduct independent inspections to verify the quality of the work;
- participate in contractor inspections;
- review test and inspection reports; and
- ensure that the required documentation is submitted.

The FOs will be alerted to detect, record, and report any deviation from the contract documents, including calling any deficient item to the attention of the ER and the contractors' Site Agents. The FOs will keep accurate and detailed records of the contractor's performance and progress, delivery of materials, and other pertinent matters, including the daily inspection report.

## 2.2 Contractor's Quality Assurance Personnel

The contractors are responsible for the quality control of their constructed work product as well as the necessary inspections and tests required to ensure that their work complies with the contract documents.

### 2.2.1 Contractor's Site Staff

The contractors' Site Agents are the primary point of contact for the Contractors on all construction management issues. The Site Agents must be full-time on site for the contractors. The Site Agents must have full authority to institute any and all actions necessary for the successful implementation of the CQC program to ensure compliance with the drawings and technical specifications.

The following procedures apply with respect to appointment of the contractor's key personnel:



## HARRY GWALA DISTRICT MUNICIPALITY

### CONSTRUCTION OF UMZIMKHULU BULK SEWER OUTFALL

HGDM 759/HGDM/2022

---

Aspect	Remarks	Approval By	When
Appointment of Site Agent	As per tender for quality based evaluated tenders	Engineer	Prior to commencement of construction
Appointment of Site Forepersons	As per tender for quality based evaluated tenders	Engineer	Prior to commencement of construction

### 2.3 Site Establishment

The Engineer's Representative shall inspect and approve/disapprove contractor's site establishment using Quality Procedure Form QC 01.

### 2.4 General

For all projects the ER must undertake the following general items as appropriate:

1	Confirm "Permission to Occupy" has been received from the relevant authority.
2	"Handover of Site" to Contractor to be confirmed in writing.
3	Inspect and approve Site Establishment (Form QC 01).
4	Setup Site Files/Filing System.
5	Ensure a copy of the Contract Document is retained on Site by the Contractor.
6	Ensure a full set/s of approved drawings is/are retained on Site by the Contractor.
7	Maintain a Drawing Register.
8	Ensure a copy of the latest Contract Program is clearly displayed on Site.
9	Establish Quality Assurance Procedures and carry out inspections as and when required.
10	Issue Site Instructions as and when required.
11	Ensure Safety File, including Dept. of Labour notification, is up to date and on Site and all relevant regulations, including issuing of PPE, are strictly adhered to.
12	Ensure all relevant information is recorded in a daily Site Diary and counter signed.
13	Hold regular Work Meetings with the Contractor.
14	Hold regular Site Meetings with the Client, Professional Team and the Contractor.
15	Maintain a copy of the Environmental Record of Decision on Site

## 3. SITE SPECIFIC QUALITY ASSURANCE PROCEDURES

## HARRY GWALA DISTRICT MUNICIPALITY

### CONSTRUCTION OF UMZIMKHULU BULK SEWER OUTFALL

#### HGDM 759/HGDM/2022

---

Quality assurance inspections and testing will be used to verify the adequacy and effectiveness of the contractor's quality control program. The Engineer's Quality Assurance Personnel detailed above will provide inspection and supervision within the scope of work, which includes monitoring of the following construction activities:

- Manufacture of materials
- Transporting and off-loading and storage of construction materials
- Inspection of construction activities, including:
  - Pipework
    - HDPE
    - STEEL
  - Building Works

The Contractor will be required to formally request for inspection for any activity which he deems to be complete before proceeding to the next stage of the whole operation. Formal requests must be filled in the **relevant QC** Form.

### 3.1 Contractor Deficiency Correction

When material, performed work or installation is found to be deficient and/or does not meet the project specifications, the Engineer's QA personnel will assure deficiency correction is implemented. In addition to results of an inspection being recorded on the relevant **QC Form**, in the event of inspection failure, the Engineer's QA personnel will fill in **Form QC 008** "Failure Report", to record the deficiencies. A copy of this report will be handed over to the Contractor's Site Agent. The Contractor will implement corrective actions to remedy work that is not in accordance with the drawings and specifications. The corrective actions will include removal and replacement of deficient work using methods approved by the ER. Removal must be done in a manner that does not disturb work that meets QC/QA criteria; otherwise, the disturbed material must also be removed and replaced. Replacement must be done in accordance with the corresponding technical specifications. Replacement will be subjected to the same scope of QC/QA inspection and testing as the original work. If the replacement work is not in accordance with the drawings and specifications, the replacement work will be removed, replaced, re inspected and re-tested.

Activities which specifically require approval before the next stage can proceed are as detailed in this section.

### 3.1 Pipework

The following procedures will be used for pipework quality assurance:

#### 3.1.1 HDPE Pipework

The ER is responsible for ensuring the following quality assurance procedure is followed, **as a minimum**:

1	Inspect & Approve Setting Out (Form QC 001).
2	Inspect & Approve Pipeline Trenches (Form QC 002).
3	Inspect & Approve Pipeline Bedding (Form QC 003).
4	Inspect & Approve Pipe Installation – HDPE (Form QC 004B).
5	Inspect & Approve Pipeline Pressure Testing (Form QC 006).
6	Inspect & Approve Backfilling to Trenches (Form QC 007).

Copies of the QC's forms are available for inspection at the offices of Zimile Consulting Engineers.

#### 3.1.2 Steel Pipework

The ER is responsible for ensuring the following quality assurance procedure is followed, **as a minimum**:

Copies of the QC's forms are available for inspection at the offices of Zimile Consulting Engineers.

1	Inspect & Approve Setting Out (Form QC 001).
2	Inspect & Approve Pipeline Trenches (Form QC 002).
3	Inspect & Approve Pipeline Bedding (Form QC 003).
4	Inspect & Approve Pipe Installation – Steel (Form QC 004A).
5	Inspect & Approve Welding of Pipes (Form QC 005).
6	Inspect & Approve Pipeline Pressure Testing (Form QC 006).
7	Inspect & Approve Backfilling to Trenches (Form QC 007).

### 3.2 Reinforced Concrete Works

The ER is responsible for ensuring the following quality assurance procedure is followed, **as a minimum**:

1	Inspect & Approve Setting Out (Form QC 001).
2	Inspect & Approve Excavations (Form QC 008).
3	Inspect & Approve Backfilling to Excavations (Form QC 009).
4	Inspect & Approve Excavations prior to Blinding (Form QC 010).
5	Inspect & Approve Cast Concrete (Form QC 016).
6	Inspect & Approve Structure prior to Concreting (Form QC 015).
7	Inspect & Approve Cast Concrete (Form QC 016).
8	Inspect & Approve Backfilling to Excavations (Form QC 009).

Copies of the QC's forms are available for inspection at the offices of Zimile Consulting Engineers.

### 3.3 Building Works

The ER is responsible for ensuring the following quality assurance procedure is followed, **as a minimum**:

1	Inspect & Approve Setting Out (Form QC 001).
2	Inspect & Approve Excavations (Form QC 008).
3	Inspect & Approve Backfilling to Excavations (Form QC 009).
4	Inspect & Approve Excavations prior to Blinding (Form QC 010).
5	Inspect & Approve Cast Concrete (Form QC 016).
6	Inspect & Approve Foundations prior to Concreting (Form QC 011).
7	Inspect & Approve Cast Concrete (Form QC 016).
8	Inspect & Approve Sub Structure Brickwork (Form QC 012).
9	Inspect & Approve Foundations prior to Surface Bed Concreting (Form QC 013).
10	Inspect & Approve Cast Concrete (Form QC 016).
11	Inspect & Approve Superstructure Brickwork (Form QC 014).
12	Ensure relevant Certificates are received/issued for the roof structure.

Copies of the QC's forms are available for inspection at the offices of Zimile Consulting Engineers.

### 3.4 Roadworks

The ER is responsible for ensuring the following quality assurance procedure is followed, **as a minimum**:

1	Inspect & Approve Setting Out (Form QC 001).
2	Inspect & Approve Excavations (Form QC 008).

## HARRY GWALA DISTRICT MUNICIPALITY

### CONSTRUCTION OF UMZIMKHULU BULK SEWER OUTFALL

#### HGDM 759/HGDM/2022

---

3	Inspect & Approve Backfilling to Excavations (Form QC 009).
4	Inspect & Approve Excavations prior to Blinding (Form QC 010).
5	Inspect & Approve Earthworks (Form QC 017).
6	Inspect & Approve Subgrade Construction (Form QC 018).
7	Inspect & Approve Pavement Layer works/Subbase (Form QC 019).
8	Inspect & Approve Base Construction (Form QC 020).
9	Inspect & Approve Culvert Construction (Form QC 021).
10	Inspect & Approve Headwalls and Wing Walls (Form QC 024).
11	Inspect & Approve Subsoil Drainage (Form QC 023).
12	Record Site Measurement (Form QC 025)

Copies of the QC's forms are available for inspection at the offices of Zimile Consulting Engineers.

## 4 DOCUMENTATION

### 4.1 Overview

An effective QA Plan depends largely on recognition of all construction activities that should be monitored and on assigning responsibilities for the monitoring of each activity. This is most effectively accomplished and verified by the documentation of quality assurance activities. The ER will document that quality assurance requirements have been addressed and satisfied. The ER will provide the Engineer with signed descriptive remarks, data sheets, and inspection reports to verify that monitoring activities have been carried out. The ER will also maintain, at the job site, a complete file of Drawings and Technical Specifications, a QA Plan, test procedures, daily diaries, and other pertinent documents.

### 4.2 Daily Site Diary

A daily construction site diary will be prepared and signed by each Site Agent and the ER. The diary will include a summary of the contractor's daily construction activities. At a minimum, the daily construction diary will include the following information:

- Date, project name, location, and other identification
- Description of weather conditions, including temperature, cloud cover, and rainfall
- Reports on any meetings held and their results
- Record of visitors to site
- Locations of construction underway during that day
- Equipment and personnel working in each activity, including subcontractors
- Descriptions of work being inspected
- Decisions made regarding approval of units of material or of work, and corrective actions to be taken
- Description of problems or delays and resolution
- Communications with contractor staff
- Construction activities completed and/or in progress
- Signature of the diary preparer

The daily site diary will be routed on a daily basis to the project QC/QA files and will be maintained as part of the permanent project record.

### **4.3 Control of Quality Records**

The ER verifies QA record accuracy and maintains copies of all quality-related documentation. This includes, but may not be limited to:

- Daily construction QA records;
- Inspection reports;
- Non-conformance (Failure) reports;
- Material receiving reports; and
- Monitoring and test data.

These records will be stored in files maintained in the project document control files. All original documents pertaining to QC information will be maintained in the project file located at the site. All records shall be available for inspection and audit, at any time, by the Engineer and the Employer.

**HARRY GWALA DISTRICT MUNICIPALITY**  
**HGDM 759/HGDM/2022**  
**CONSTRUCTION OF UMZIMKHULU BULK SEWER OUTFALL**  
**PART C4: SITE INFORMATION**

**INDEX**

<b>HARRY GWALA DISTRICT MUNICIPALITY</b> .....	<b>1</b>
<b>PART C4: SITE INFORMATION</b> .....	<b>2</b>
C4.1 LOCALITY PLAN.....	2
C4.1.1 Access.....	2
C4.2 CONDITIONS ON SITE .....	2
C4.2.1 Nature of Ground and Subsoil Conditions .....	2
C4.2.2 Weather Conditions.....	2
C4.2.3 Limitations .....	4

## PART C4: SITE INFORMATION

### C4.1 LOCALITY PLAN

The Locality of the site is as per the attached Locality Plan which is part of the list of Tender drawings.

#### C4.1.1 Access

Table below shows the location of uMzimkhulu Town which the construction works will be conducted.

Project Name	Towns	Latitude	Longitude	Local Municipality
uMzimkhulu Bulk Sewer	uMzimkhulu	30°15'51.18"S	29°55'8.83"E	uMzimkhulu Local Municipality

### C4.2 CONDITIONS ON SITE

A brief description of the site conditions is given under this section.

#### C4.2.1 Nature of Ground and Subsoil Conditions

A detailed Geotechnical investigation was conducted on this project including core drills at the pump station site. A Geotech report shall be provided to bidders upon request, .

#### C4.2.2 Weather Conditions

The average temperature in uMzimkhulu is about 19 °C. The monthly highest average temperature occurs in January and February at 23 °C. The lowest monthly average temperatures are experienced in June and July averaging at 4 °C. The average temperatures for uMzimkhulu Town are shown below.



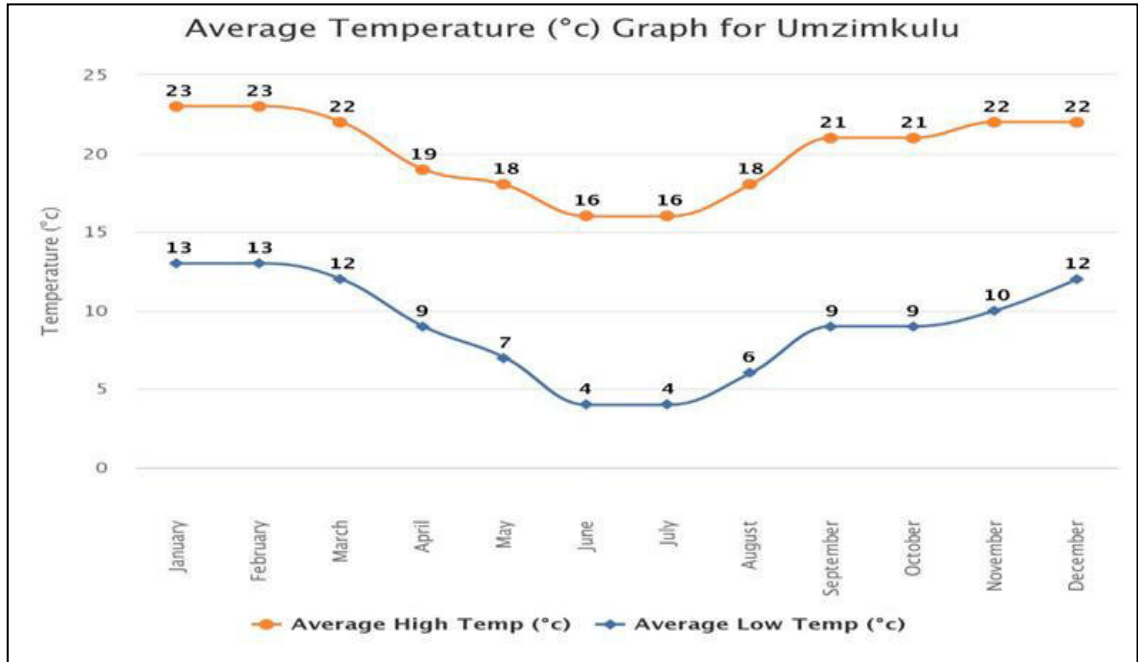

The summers are much rainier than the winters in uMzimkhulu LM. uMzimkhulu town receives a significant amount of rainfall during the year of about 633 mm. The least amount of rainfall occurs in June with an average of 6 mm of rain. The most precipitation falls in January with an average of 126.6 mm. The Figure below shows the rainfall patterns over a 12-month period within the study area in this report.

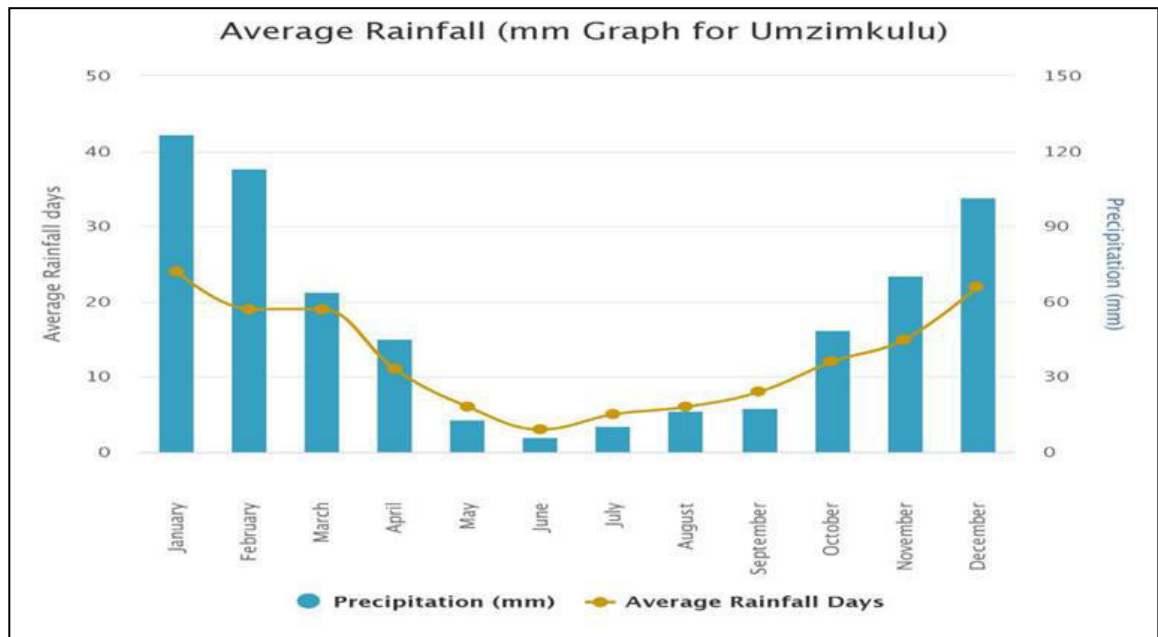

### **C4.2.3 Limitations**

The following limitations characterise the site of the pipeline construction

- Extra care will have to be exercised with regards the activities of the Contractor's labour while they are on site to ensure that there is no undue damage to private property as a result of construction activities.
- The Contractor will be required to ensure that the insurances for the works cover any damage that may occur to private properties as a result of construction activities. Should there be any claims against the contractor resulting from construction activities, the Engineer will ensure that these have been addressed or the damages rectified prior to the release of the retention held on the contract.

**HARRY GWALA DISTRICT MUNICIPALITY**  
**HGDM 759/HGDM/2022**  
**CONSTRUCTION OF UMZIMKHULU BULK SEWER OUTFALL**  
**PART C4: DRAWINGS**

**INDEX**

**PART C5: DRAWING.....D1**

# HARRY GWALA DISTRICT MUNICIPALITY



CONTRACT NO.:W/19-20/1PLANNING /UMZIMKHULU BULK SEWER

## UMZIMKHULU BULK SEWER OUTFALL SEWER



TENDER DRAWINGS

OCTOBER 2021

PREPARED BY:  **ZIMILE**  
*Consulting Engineers*

DRAWING LIST	
DWG No.	DESCRIPTION
CIVIL	
PART A: LAYOUT DRAWINGS	
J000096-WT-LA-000	LIST OF DRAWINGS
J000096-WT-LA-001	GENERAL SITE LAYOUT_SHT 1
J000096-WT-LA-002	GENERAL SITE LAYOUT_SHT 2
PART B: PLAN AND LONG SECTIONS	
J000096-WT-LS-100	LONG SECTION - SHT 1
J000096-WT-LS-101	LONG SECTION - SHT 2
J000096-WT-LS-102	LONG SECTION - SHT 3
J000096-WT-LS-103	LONG SECTION - SHT 4
PART C: PIPE SPECIALS AND TYPICAL CONCRETE DETAILS	
J000096-WT-DE-000	OUTFALL SEWER COVER PAGE
J000096-WT-DE-200	315mm DIA PIPE TYPE 1 SEWER MANHOLE DETAILS
J000096-WT-DE-201	315mm DIA PIPE TYPE 2 SEWER MANHOLE DETAILS
J000096-WT-DE-202	355mm DIA PIPE TYPE 1 SEWER MANHOLE DETAILS
J000096-WT-DE-203	355mm DIA PIPE TYPE 2 SEWER MANHOLE DETAILS
J000096-WT-DE-204	450mm DIA PIPE TYPE 1 SEWER MANHOLE DETAILS
J000096-WT-DE-205	450mm DIA PIPE TYPE 2 SEWER MANHOLE DETAILS
J000096-WT-DE-206	500mm DIA PIPE TYPE 1 SEWER MANHOLE DETAILS
J000096-WT-DE-207	500mm DIA PIPE TYPE 2 SEWER MANHOLE DETAILS

**FOR APPROVAL  
PURPOSES**

		DESIGNED	N. NDLOVU NAME	 <p>INTERNATIONAL BUSINESS GATEWAY OFFICE PARK CNR PIONEER AVENUE AND ELIZABETH MIDRIDGE PARK TEL: (011) 466 - 8576 FAX: (011) 466 - 8813 E-MAIL: info@zimile.co.za</p> <p>COPYRIGHT RESERVED ©</p>	REFERENCE DRAWINGS:	CLIENT:	APPROVED:	PROJECT:	PROJECT PHASE					
		DRAWN	N. STUURMAN NAME		1.		<b>N. NDLOVU</b> FOR ZIMILE CONSULTING ENGINEERS DESIGNATION: <b>PROJECT LEADER</b> DATE: _____ SIGNATURE: _____	<b>UMZIMKHULU BULK SEWER</b>  TITLE: <b>OUTFALL SEWER DRAWING LIST</b>	PRELIMINARY	TENDER	CONSTRUCTION	AS-BUILT		
		CHECKED	N. NDLOVU NAME		2.				DATE: <b>OCTOBER 2021</b>	SCALE: <b>AS SHOWN</b>	DRAWING No.	REVISION		
A	ISSUED FOR TENDER	07/10/2021			3.				J000096	ZCE	DL	000	A	
NO.	NATURE OF REVISION	DATE		4.	CAD FILENAME				<small>Z:\Current Projects\WATER DEPARTMENT\J000096 - Umzimkhulu Bulk Sewer\4. Procurement Stage1 - Tender Drawings\01 Water\01 Working Drawings\J000096-WT-CL-000_Part3_Outfall Sewer Drawing List.dwg</small>			SIZE <b>A1</b>		



STRUCTURE LIST-NORTHERN OUTFALL SEWER				
MH. NAME	Y	X	RIM ELEVATION	RIM TO SUMP DEPTH
MH0	-88 395.829	3 349 446.700	759.194	4.580
MH1	-88 475.343	3 349 455.510	755.524	7.077
MH2	-88 554.856	3 349 464.320	750.955	3.105
MH3	-88 586.267	3 349 467.800	749.000	5.046
MH4	-88 674.342	3 349 475.340	744.821	2.795
MH5	-88 734.123	3 349 480.458	743.034	1.967
MH6	-88 754.050	3 349 482.163	742.496	1.425
MH7	-88 796.973	3 349 485.838	742.471	2.275
MH8	-88 873.836	3 349 482.864	741.121	1.888
MH9	-88 933.791	3 349 480.545	740.242	1.453
MH10	-88 953.221	3 349 479.793	740.000	2.342
MH11	-89 032.100	3 349 463.445	738.565	1.963
MH12	-89 110.435	3 349 447.210	737.571	1.922
MH13	-89 130.019	3 349 443.152	737.831	1.814
MH14	-89 188.771	3 349 430.975	737.613	1.973
MH15	-89 247.522	3 349 418.799	738.127	2.765
MH16	-89 277.230	3 349 412.642	737.212	2.051
MH17	-89 305.614	3 349 404.035	738.488	3.525
MH18	-89 363.032	3 349 386.623	738.724	4.112
MH19	-89 415.619	3 349 370.676	739.014	4.726
MH20	-89 473.350	3 349 357.862	740.000	6.058
MH21	-89 509.702	3 349 353.314	738.870	5.161
MH22	-89 550.048	3 349 342.974	739.458	6.008
MH23	-89 617.636	3 349 340.667	738.698	5.636
MH24	-89 692.245	3 349 338.122	739.585	6.945
MH25	-89 742.963	3 349 344.969	738.050	5.755
MH26	-89 750.601	3 349 334.998	738.892	6.710
MH27	-89 730.534	3 349 309.868	738.337	6.366
MH28	-89 724.256	3 349 253.576	737.000	5.362
MH29	-89 712.474	3 349 192.083	734.557	3.513
MH30	-89 677.086	3 349 122.483	732.000	2.380
MH31	-89 667.171	3 349 104.773	730.865	3.104
MH32	-89 615.319	3 349 043.321	728.706	2.018
MH33	-89 557.596	3 348 992.255	727.650	1.397
MH34	-89 555.277	3 348 935.259	727.531	1.748
MH36	-89 305.696	3 349 404.054	738.490	1.437
MH37	-89 306.327	3 349 400.000	738.340	2.035
MH38	-89 301.333	3 349 384.498	737.533	4.229
MH39	-89 294.095	3 349 351.471	734.444	3.169
MH40	-89 334.744	3 349 275.470	732.430	2.301
MH41	-89 372.470	3 349 204.935	731.038	2.221
MH42	-89 417.364	3 349 138.707	729.726	2.320
MH43	-89 462.253	3 349 072.488	728.334	1.807
MH44	-89 507.141	3 349 006.269	727.750	1.716
MH45	-89 572.921	3 348 882.213	728.000	2.547
MH46	-89 619.846	3 348 846.635	728.421	3.312
MH47	-89 696.590	3 348 863.981	728.078	3.413

PIPE LIST-NORTHERN OUTFALL SEWER				
NAME	START LEVEL	END LEVEL	Dis. (m)	Diam. (mm)
P0	754.615	754.215	78.753	315 mm Class 51
P1	750.046	749.646	78.753	315 mm Class 51
P2	747.849	747.691	30.355	315 mm Class 51
P3	743.954	743.512	87.149	315 mm Class 51
P4	742.025	741.725	58.752	315 mm Class 51
P5	741.287	741.187	18.752	315 mm Class 51
P6	741.137	740.921	41.832	315 mm Class 51
P7	740.196	739.812	75.672	315 mm Class 51
P8	739.233	738.933	58.752	315 mm Class 51
P9	738.788	738.691	18.197	315 mm Class 51
P10	737.658	737.256	79.308	315 mm Class 51
P11	736.663	736.263	78.753	315 mm Class 51
P12	736.213	736.113	18.752	315 mm Class 51
P13	736.063	735.763	58.752	315 mm Class 51
P14	735.713	735.413	58.752	315 mm Class 51
P15	735.363	735.211	29.091	315 mm Class 51
P16	735.161	735.013	28.413	315 mm Class 51
P17	734.963	734.663	58.752	315 mm Class 51
P18	734.613	734.338	53.703	315 mm Class 51
P19	734.288	733.992	57.888	315 mm Class 51
P20	733.942	733.759	35.387	315 mm Class 51
P21	733.709	733.501	40.402	315 mm Class 51
P22	733.451	733.113	66.380	315 mm Class 51
P23	733.063	732.689	73.405	315 mm Class 51
P24	732.639	732.383	49.931	315 mm Class 51
P25	732.295	732.232	11.312	355 mm Class 51
P26	732.182	732.021	30.911	355 mm Class 51
P27	731.971	731.688	55.394	355 mm Class 51
P28	731.638	731.325	61.364	355 mm Class 51
P29	731.043	730.653	76.832	355 mm Class 51
P30	729.620	729.518	19.049	355 mm Class 51
P31	727.761	727.359	79.158	355 mm Class 51
P32	726.688	726.303	75.823	355 mm Class 51
P33	726.253	725.968	55.795	315 mm Class 51
P35	737.052	737.032	3.196	315 mm Class 51
P36	736.306	736.224	15.038	315 mm Class 51
P37	733.304	733.135	32.563	315 mm Class 51
P38	731.553	731.122	84.942	355 mm Class 51
P39	730.129	729.729	78.743	355 mm Class 51
P40	728.818	728.418	78.762	355 mm Class 51
P41	727.425	727.025	78.753	355 mm Class 51
P42	726.841	726.441	78.753	355 mm Class 51
P43	726.391	725.962	84.540	355 mm Class 51
P44	725.783	725.503	54.657	450 mm Class 51
P45	725.453	725.159	57.640	450 mm Class 51
P46	725.109	724.715	77.433	450 mm Class 51
P47	724.665	724.265	78.753	450 mm Class 51

BENCH MARKS			
NAME	YLo	XLo	Z
BM09	-90 122.512	3 348 998.798	726.801
BM10	-89 639.464	3 348 861.844	728.472
BM11	-89 520.367	3 349 007.852	727.931
BM13	-89 653.847	3 349 099.132	731.550
BM14	-89 664.124	3 349 318.773	738.804
BM16	-89 263.067	3 349 399.099	738.264
BM17	-88 514.933	3 349 456.960	752.024

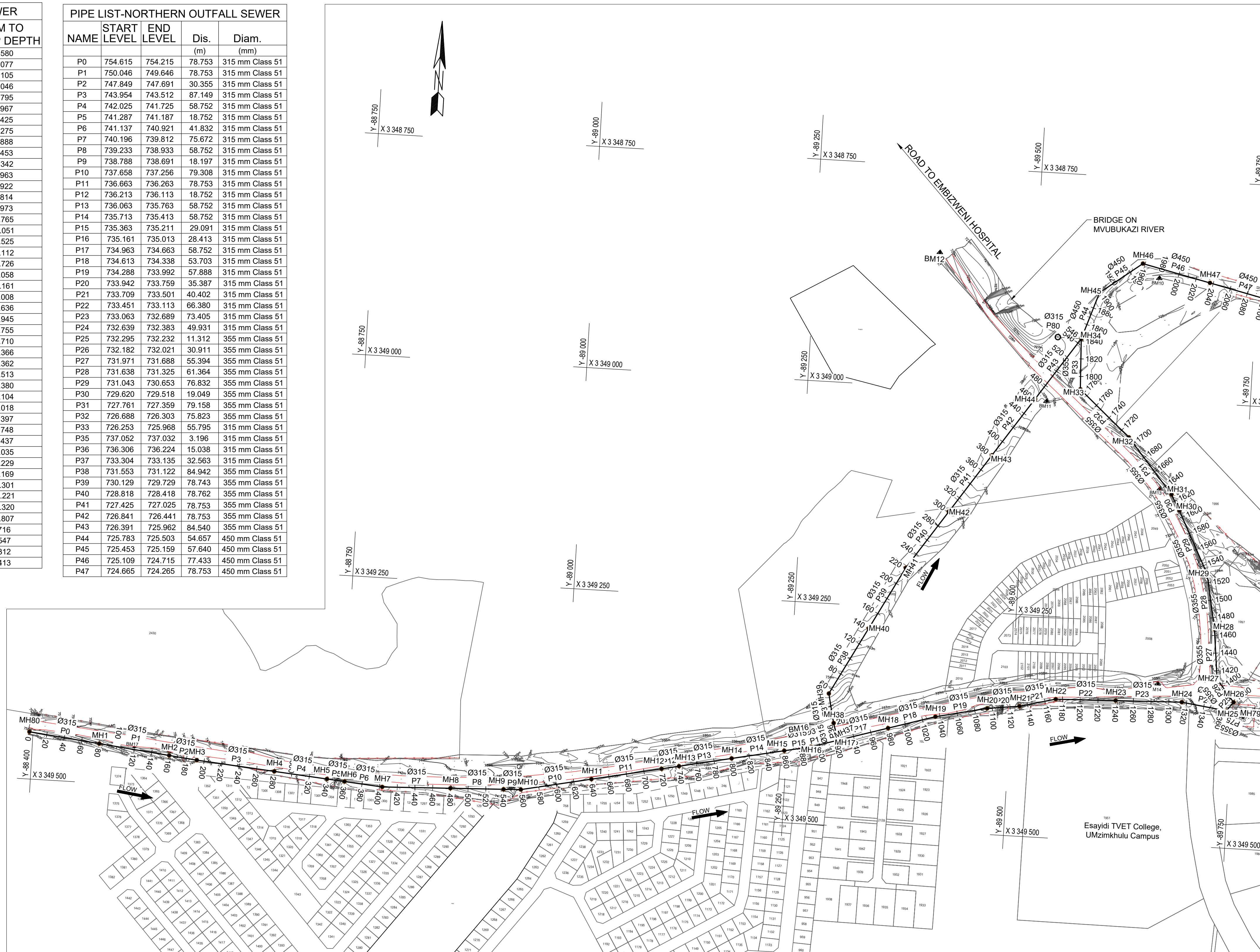

NORTHERN OUTFALL SEWER PLAN  
SCALE 1:2500

NOTES:

- THIS DESIGN WAS ENGINEERED BY : ZIMILE CONSULTING ENGINEERS
- THESE DRAWINGS MUST BE READ IN CONJUNCTION WITH THE SANS AND PROJECT SPECIFICATIONS.
- ALL SETTING OUT AND DIMENSIONS MUST BE CONFIRMED AND APPROVED ON SITE
- ALL CONSTRUCTION TO BE DONE IN ACCORDANCE WITH THE SANS AND PROJECT SPECIFICATIONS.
- ALL MATERIAL AND WORKMANSHIP MUST COMPLY WITH THE REQUIREMENTS OF THE LATEST RELEVANT SANS AND PROJECT SPECIFICATIONS
- THE CONTRACTOR SHALL REPORT ANY DISCREPANCIES TO THE ENGINEER WITH REGARDS TO THE BOQ, DRAWINGS AND SPECIFICATION BEFORE ORDERING ANY MATERIAL.
- FINAL POSITION OF SERVICES TO BE DETERMINED ON SITE.
- THE CONTRACTOR SHALL DETERMINE THE EXACT LOCATION OF ALL POTENTIALLY CLASHING EXISTING SERVICES AND PROTECT THEM FROM DAMAGE THROUGHOUT THE DURATION OF THE WORKS
- PIPES TO BE LAID AT LEAST 1m AWAY FROM THE STAND BOUNDARIES AND 1m AWAY FROM THE ROAD EDGE

LEGEND

- SITE BOUNDARY
- PROPOSED SEWER PIPELINE
- EXISTING SEWER PIPELINE
- PIPE MATERIAL & CLASS
- PROPOSED MANHOLES
- FUTURE GRAVITY OUTFALL
- BENCH MARK
- FENCE
- TREES
- ROAD
- CONTOURS
- EXISTING CULVERTS
- CHAINAGE
- STREAM CROSSING
- ROAD CROSSING
- MANHOLE

SCALE 1:2 500

FOR TENDER PURPOSES ONLY

DESIGNED	N. NDLOVU
DRAWN	N. STUURMAN
CHECKED	B. SEAKE
ISSUED FOR TENDER	08/07/2021
NATURE OF REVISION	DATE

**ZIMILE**  
Consulting Engineers

INTERNATIONAL BUSINESS GATEWAY OFFICE PARK  
CNR PIONEER AVENUE AND ELIZABETH MIDRIDGE PARK  
TEL: (011) 466- 8576  
FAX: (011) 466- 8813  
E-MAIL: info@zimile.co.za  
COPYRIGHT RESERVED ©

SCALE BAR

0 70

70mm ON ORIGINAL DRAWING

CLIENT:

APPROVED:

B. SEAKE  
FOR ZIMILE CONSULTING ENGINEERS

DESIGNATION: TECHNICAL MANAGER

DATE: \_\_\_\_\_ SIGNATURE: \_\_\_\_\_

PROJECT:

UMZIMKHULU BULK SEWER

TITLE:

GENERAL SITE LAYOUT - SHEET 1 OF 2

PROJECT PHASE			
PRELIMINARY	TENDER	CONSTRUCTION	AS-BUILT
DATE:	JULY 2021	SCALE:	AS SHOWN
DRAWING No.	J000096	WT	LA
CAD FILENAME		001	A
			A1



**STRUCTURE LIST-NORTHERN OUTFALL SEWER**

MH. NAME	Y	X	INVERT LEVEL	DEPTH TO SUMP
MH48	-89 774.621	3 348 881.618	727.811	3.987
MH49	-89 860.996	3 348 901.141	727.505	3.783
MH50	-89 948.628	3 348 927.278	727.410	4.195
MH51	-90 025.290	3 348 950.144	727.100	4.726
MH52	-90 107.231	3 348 974.583	727.000	4.712
MH53	-90 192.101	3 349 016.127	726.743	4.978
MH54	-90 263.955	3 349 051.298	726.575	5.651
MH55	-90 335.808	3 349 086.470	726.484	6.010
MH56	-90 392.860	3 349 114.397	726.756	6.259
MH57	-90 438.434	3 349 147.759	726.529	6.364
MH58	-90 488.428	3 349 184.357	726.511	6.753
MH59	-90 541.314	3 349 161.132	726.787	7.384
MH60	-90 573.024	3 349 189.680	727.074	7.933
MH61	-90 574.909	3 349 231.010	726.616	7.730
MH62	-90 577.831	3 349 246.320	726.515	7.725
MH63	-90 579.249	3 349 277.845	726.558	7.962
MH64	-90 578.066	3 349 296.407	726.383	7.901
MH65	-90 625.159	3 349 290.385	726.365	8.176
MH66	-90 634.602	3 349 310.606	726.219	8.167
MH67	-90 636.737	3 349 331.294	726.069	8.145
MH68	-90 649.982	3 349 410.095	725.681	8.314
MH69	-90 663.635	3 349 491.326	725.259	8.333
MH70	-90 676.894	3 349 498.781	725.157	8.326
MH71	-90 693.875	3 349 599.782	724.729	8.527
MH72	-90 707.139	3 349 678.675	723.816	8.259
MH73	-90 723.162	3 349 773.974	722.034	6.919
MH74	-90 710.468	3 349 796.593	723.238	8.286
MH75	-90 575.846	3 349 301.019	726.300	1.309
MH76	-89 528.795	3 348 934.995	726.723	0.809
MH77	-90 656.735	3 349 494.599	725.270	1.487
MH79	-89 761.545	3 349 351.329	738.592	1.742
MH80	-88 395.374	3 349 443.181	757.651	1.309
MH81	-90 486.672	3 349 189.206	726.427	1.309

**PIPE LIST-NORTHERN OUTFALL SEWER**

PIPE NAME	START LEVEL	END LEVEL	Dis. (m)	Diam. (mm)
P48	724.215	723.772	87.307	450 mm Class 51
P49	723.772	723.265	90.200	450 mm Class 51
P50	723.215	722.815	78.753	450 mm Class 51
P51	722.765	722.338	84.261	450 mm Class 51
P52	722.288	721.815	93.246	450 mm Class 51
P53	721.765	721.365	78.753	450 mm Class 51
P54	721.315	720.915	78.753	450 mm Class 51
P55	720.865	720.548	62.273	450 mm Class 51
P56	720.498	720.215	55.233	450 mm Class 51
P57	720.165	719.855	60.711	450 mm Class 51
P58	719.757	719.403	56.515	500 mm Class 51
P59	719.403	719.140	41.422	500 mm Class 51
P60	719.140	718.886	40.127	500 mm Class 51
P61	718.886	718.790	14.340	500 mm Class 51
P62	718.790	718.596	30.311	500 mm Class 51
P63	718.596	718.481	17.353	500 mm Class 51
P64	718.481	718.189	46.230	500 mm Class 51
P65	718.189	718.052	21.071	500 mm Class 51
P66	718.052	717.924	19.550	500 mm Class 51
P67	717.924	717.432	78.661	500 mm Class 51
P68	717.432	716.925	81.125	500 mm Class 51
P69	716.925	716.832	13.965	500 mm Class 51
P70	716.832	716.202	101.173	500 mm Class 51
P71	716.202	715.710	78.755	500 mm Class 51
P72	715.709	715.115	95.391	500 mm Class 51
P73	715.115	714.952	25.016	500 mm Class 51
P74	756.342	756.325	2.625	315 mm Class 51
P75	736.850	736.687	18.719	355 mm Class 51
P76	725.118	725.075	4.235	315 mm Class 51
P77	723.784	723.720	6.391	500 mm Class 51
P78	724.991	724.949	4.196	315 mm Class 51
P80	725.914	725.800	25.560	315 mm Class 51

**BENCH MARKS**

NAME	YLo	XLo	Z
BM01	-90 742.534	3 349 797.319	722.912
BM02	-90 665.326	3 349 497.181	725.068
BM03	-90 538.818	3 349 436.055	725.597
BM04	-90 630.890	3 349 296.787	726.303
BM05	-90 575.530	3 349 297.163	726.415
BM06	-90 551.944	3 349 171.378	726.522
BM07	-90 483.860	3 349 190.268	726.509
BM08	-90 378.817	3 349 110.227	726.627



**NORTHERN OUTFALL SEWER PLAN**  
SCALE 1:2500

- NOTES:**
- THIS DESIGN WAS ENGINEERED BY : ZIMILE CONSULTING ENGINEERS
  - THESE DRAWINGS MUST BE READ IN CONJUNCTION WITH THE SANS AND PROJECT SPECIFICATIONS.
  - ALL SETTING OUT AND DIMENSIONS MUST BE CONFIRMED AND APPROVED ON SITE
  - ALL CONSTRUCTION TO BE DONE IN ACCORDANCE WITH THE SANS AND PROJECT SPECIFICATIONS.
  - ALL MATERIAL AND WORKMANSHIP MUST COMPLY WITH THE REQUIREMENTS OF THE LATEST RELEVANT SANS AND PROJECT SPECIFICATIONS
  - THE CONTRACTOR SHALL REPORT ANY DISCREPANCIES TO THE ENGINEER WITH REGARDS TO THE BOQ, DRAWINGS AND SPECIFICATION BEFORE ORDERING ANY MATERIAL.
  - FINAL POSITION OF SERVICES TO BE DETERMINED ON SITE.
  - THE CONTRACTOR SHALL DETERMINE THE EXACT LOCATION OF ALL POTENTIALLY CLASHING EXISTING SERVICES AND PROTECT THEM FROM DAMAGE THROUGHOUT THE DURATION OF THE WORKS
  - PIPES TO BE LAID AT LEAST 1m AWAY FROM THE STAND BOUNDARIES AND 1m AWAY FROM THE ROAD EDGE

**LEGEND**

- SITE BOUNDARY
- PROPOSED SEWER PIPELINE
- EXISTING SEWER PIPELINE
- PIPE MATERIAL & CLASS
- PROPOSED MANHOLES
- FUTURE GRAVITY OUTFALL
- BENCH MARK
- FENCE
- TREES
- ROAD
- CONTOURS
- EXISTING CULVERTS
- CHAINAGE
- STREAM CROSSING
- ROAD CROSSING
- MANHOLE

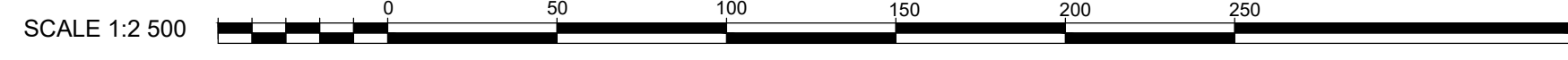

**FOR TENDER PURPOSES ONLY**

DESIGNED	N. NDLOVU
DRAWN	N. STUURMAN
CHECKED	B. SEAKE
ISSUED FOR TENDER	08/072021
NATURE OF REVISION	DATE

**ZIMILE Consulting Engineers**  
INTERNATIONAL BUSINESS GATEWAY OFFICE PARK  
CNR PIONEER AVENUE AND ELIZABETH MIDRIDGE PARK  
TEL: (011) 466-8576 FAX: (011) 466-8813  
E-MAIL: info@zimile.co.za  
COPYRIGHT RESERVED ©

SCALE BAR: 0 70  
70mm ON ORIGINAL DRAWING

CLIENT:   
APPROVED: B. SEAKE FOR ZIMILE CONSULTING ENGINEERS  
DESIGNATION: TECHNICAL MANAGER  
DATE: SIGNATURE:

PROJECT: UMZIMKHULU BULK SEWER  
TITLE: GENERAL SITE LAYOUT - SHEET 2 OF 2

PROJECT PHASE			
PRELIMINARY	TENDER	CONSTRUCTION	AS-BUILT
DATE: JULY 2021	SCALE: AS SHOWN		
DRAWING No. J000096	WT	LA	002
CAD FILENAME			SIZE: A1



MH. NAME	Y	X	RIM ELEVATION	RIM TO SUMP DEPTH
MH0	-88 395.829	3 349 446.700	759.194	4.580
MH1	-88 475.343	3 349 455.510	755.524	7.077
MH2	-88 554.856	3 349 464.320	750.955	3.105
MH3	-88 586.267	3 349 467.800	749.000	5.046
MH4	-88 674.342	3 349 475.340	744.821	2.795
MH5	-88 734.123	3 349 480.458	743.034	1.967
MH6	-88 754.050	3 349 482.163	742.496	1.425
MH7	-88 796.973	3 349 485.838	742.471	2.275
MH8	-88 873.836	3 349 482.864	741.121	1.888
MH9	-88 933.791	3 349 480.545	740.242	1.453
MH10	-88 953.221	3 349 479.793	740.000	2.342
MH11	-89 032.100	3 349 463.445	738.565	1.963
MH12	-89 110.435	3 349 447.210	737.571	1.922
MH13	-89 130.019	3 349 443.152	737.831	1.814
MH14	-89 188.771	3 349 430.975	737.613	1.973
MH15	-89 247.522	3 349 418.799	738.127	2.765
MH16	-89 277.230	3 349 412.642	737.212	2.051
MH17	-89 305.614	3 349 404.035	738.488	3.525
MH18	-89 363.032	3 349 386.623	738.724	4.112
MH19	-89 415.619	3 349 370.676	739.014	4.726
MH20	-89 473.350	3 349 357.862	740.000	6.058
MH21	-89 509.702	3 349 353.314	738.870	5.161
MH22	-89 550.048	3 349 342.974	739.458	6.008
MH23	-89 617.636	3 349 340.667	738.698	5.636
MH24	-89 692.245	3 349 338.122	739.585	6.945
MH25	-89 742.963	3 349 344.969	738.050	5.755
MH26	-89 750.601	3 349 334.998	738.892	6.710
MH27	-89 730.534	3 349 309.868	738.337	6.366
MH28	-89 724.256	3 349 253.576	737.000	5.362
MH29	-89 712.474	3 349 192.083	734.557	3.513
MH30	-89 677.086	3 349 122.483	732.000	2.380
MH31	-89 667.171	3 349 104.773	730.865	3.104
MH32	-89 615.319	3 349 043.321	728.706	2.018
MH33	-89 557.596	3 348 992.255	727.650	1.397
MH34	-89 555.277	3 348 935.259	727.531	1.748
MH36	-89 305.596	3 349 404.054	738.490	1.437
MH37	-89 306.327	3 349 400.000	738.340	2.035
MH38	-89 301.333	3 349 384.498	737.533	4.229
MH39	-89 294.095	3 349 351.471	734.444	3.169
MH40	-89 334.744	3 349 275.470	732.430	2.301
MH41	-89 372.470	3 349 204.935	731.038	2.221
MH42	-89 417.364	3 349 138.707	729.726	2.320
MH43	-89 462.253	3 349 072.488	728.334	1.807
MH44	-89 507.141	3 349 006.269	727.750	1.716
MH45	-89 572.921	3 348 882.213	728.000	2.547
MH46	-89 619.846	3 348 846.635	728.421	3.312
MH47	-89 696.590	3 348 863.981	728.078	3.413

NAME	Y	X
MH112	-90 626.238	3 349 830.658
N0	-90 710.468	3 349 796.593
N1	-90 671.124	3 349 803.809
N2	-90 632.503	3 349 810.893
N3	-90 618.378	3 349 855.454
N4	-90 629.239	3 349 908.339
N5	-90 637.286	3 349 947.521
N6	-90 654.455	3 350 031.123
N7	-90 649.185	3 350 062.626
N8	-90 611.198	3 350 112.525
N9	-90 594.704	3 350 134.192
N10	-90 624.462	3 350 303.065
N11	-90 643.578	3 350 418.780
N12	-90 661.097	3 350 425.890
N13	-90 665.757	3 350 450.434
N14	-90 669.875	3 350 472.304
N15	-90 698.542	3 350 501.745
N16	-90 720.657	3 350 553.904
N17	-90 759.694	3 350 645.970
N18	-90 786.484	3 350 709.152
N19	-90 828.422	3 350 825.801
N20	-90 833.723	3 350 840.543
N21	-90 823.545	3 350 854.008
N22	-90 821.467	3 350 873.899
N23	-90 819.922	3 350 888.688
N24	-90 798.999	3 351 088.998
N25	-90 792.778	3 351 094.799

NAME	YLo	XLo	Z
BM01	-90 742.534	3 349 797.319	722.912
BM02	-90 665.326	3 349 497.181	725.068
BM03	-90 538.818	3 349 436.055	725.597
BM04	-90 630.890	3 349 296.787	726.303
BM05	-90 575.530	3 349 297.163	726.415
BM06	-90 551.944	3 349 171.378	726.522
BM07	-90 483.860	3 349 190.268	726.509
BM08	-90 378.817	3 349 110.227	726.627
BM09	-90 122.512	3 348 998.798	726.801
BM10	-89 639.464	3 348 861.844	728.472
BM11	-89 520.367	3 349 007.852	727.931
BM13	-89 653.847	3 349 099.132	731.550
BM14	-89 664.124	3 349 318.773	738.804
BM16	-89 263.067	3 349 399.099	738.264
BM17	-88 514.933	3 349 456.960	752.024

NAME	YLo	XLo	Z
BM20	-90 603.628	3 350 148.855	725.63
BM21	-90 652.287	3 350 468.884	726.17
BM22	-90 825.899	3 350 870.392	722.17
BM23	-90 799.611	3 351 061.891	724.65
BM24	-90 802.620	3 351 113.841	726.81

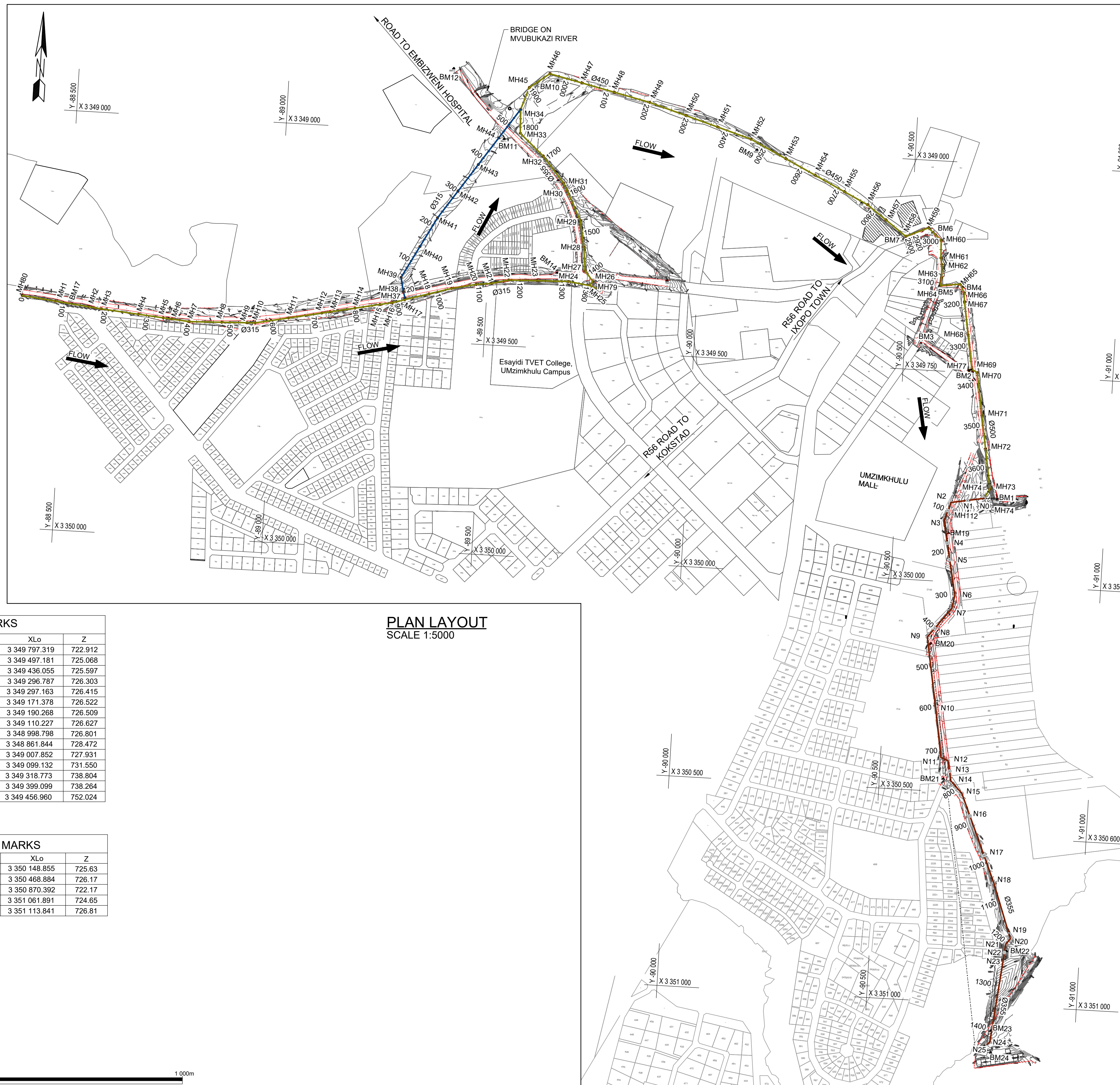

PLAN LAYOUT  
SCALE 1:5000

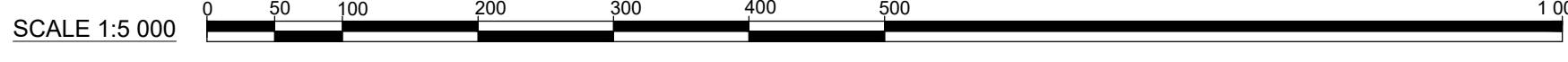

- NOTES:**
- THIS DESIGN WAS ENGINEERED BY : ZIMILE CONSULTING ENGINEERS
  - THESE DRAWINGS MUST BE READ IN CONJUNCTION WITH THE SANS AND PROJECT SPECIFICATIONS.
  - ALL SETTING OUT AND DIMENSIONS MUST BE CONFIRMED AND APPROVED ON SITE
  - ALL CONSTRUCTION TO BE DONE IN ACCORDANCE WITH THE SANS AND PROJECT SPECIFICATIONS.
  - ALL MATERIAL AND WORKMANSHIP MUST COMPLY WITH THE REQUIREMENTS OF THE LATEST RELEVANT SANS AND PROJECT SPECIFICATIONS
  - THE CONTRACTOR SHALL REPORT ANY DISCREPANCIES TO THE ENGINEER WITH REGARDS TO THE BOQ, DRAWINGS AND SPECIFICATION BEFORE ORDERING ANY MATERIAL.
  - FINAL POSITION OF SERVICES TO BE DETERMINED ON SITE.
  - THE CONTRACTOR SHALL DETERMINE THE EXACT LOCATION OF ALL POTENTIALLY CLASHING EXISTING SERVICES AND PROTECT THEM FROM DAMAGE THROUGHOUT THE DURATION OF THE WORKS
  - PIPES TO BE LAID AT LEAST 1m AWAY FROM THE STAND BOUNDARIES AND 1m AWAY FROM THE ROAD EDGE

**LEGEND**

- SITE BOUNDARY
- PROPOSED SEWER PIPELINE
- EXISTING SEWER PIPELINE
- PIPE MATERIAL & CLASS
- PROPOSED MANHOLES
- FUTURE GRAVITY OUTFALL
- BENCH MARK
- FENCE
- TREES
- ROAD
- CONTOURS
- EXISTING CULVERTS
- CHAINAGE
- STREAM CROSSING
- ROAD CROSSING
- MANHOLE

**LEGEND**

- BULK SEWER RISING MAIN
- BYPASS SEWER PIPELINE
- NOTHRN OUTFALL SEWER PIPELINE

**FOR TENDER PURPOSES ONLY**

DESIGNED	N. NDLOVU
DRAWN	N. STUURMAN
CHECKED	B. SEAKE
ISSUED FOR TENDER	08/07/2021
NATURE OF REVISION	DATE

**ZIMILE Consulting Engineers**

INTERNATIONAL BUSINESS GATEWAY OFFICE PARK  
CNR PIONEER AVENUE AND ELIZABETH MIDRIDGE PARK

TEL: (011) 466-8576  
FAX: (011) 466-8813  
E-MAIL: info@zimile.co.za

COPYRIGHT RESERVED ©

SCALE BAR: 0 70 70mm ON ORIGINAL DRAWING

CLIENT:

APPROVED: B. SEAKE FOR ZIMILE CONSULTING ENGINEERS  
DESIGNATION: TECHNICAL MANAGER  
DATE: \_\_\_\_\_ SIGNATURE: \_\_\_\_\_

PROJECT: UMZIMKHULU BULK SEWER

TITLE: OUTFALL SEWER AND BULK SEWER RISING MAIN GENERAL SITE LAYOUT

PROJECT PHASE			
PRELIMINARY	TENDER	CONSTRUCTION	AS-BUILT
DATE: JULY 2021	SCALE: AS SHOWN		
DRAWING No. J000096	WT	LA	004
CAD FILENAME			
			REVISION
			A
			SIZE A1



**STRUCTURE LIST-NORTHERN OUTFALL SEWER**

MH. NAME	Y	X	RIM ELEVATION	RIM TO SUMP DEPTH
MH0	-88 395.829	3 349 446.700	759.194	4.580
MH1	-88 475.343	3 349 455.510	755.524	7.077
MH2	-88 554.856	3 349 464.320	750.955	3.105
MH3	-88 586.267	3 349 467.800	749.000	5.046
MH4	-88 674.342	3 349 475.340	744.821	2.795
MH5	-88 734.123	3 349 480.458	743.034	1.967
MH6	-88 754.050	3 349 482.163	742.496	1.425
MH7	-88 796.973	3 349 485.838	742.471	2.275
MH8	-88 873.836	3 349 482.864	741.121	1.888
MH9	-88 933.791	3 349 480.545	740.242	1.453
MH10	-88 953.221	3 349 479.793	740.000	2.342
MH11	-89 032.100	3 349 463.445	738.565	1.963
MH12	-89 110.435	3 349 447.210	737.571	1.922
MH13	-89 130.019	3 349 443.152	737.831	1.814
MH14	-89 188.771	3 349 430.975	737.613	1.973
MH15	-89 247.522	3 349 418.799	738.127	2.765

**PIPE LIST-NORTHERN OUTFALL SEWER**

NAME	START LEVEL	END LEVEL	Dis. (m)	Diam. (mm)
P0	754.615	754.215	78.753	315 mm Class 51
P1	750.046	749.646	78.753	315 mm Class 51
P2	747.849	747.691	30.355	315 mm Class 51
P3	743.954	743.512	87.149	315 mm Class 51
P4	742.025	741.725	58.752	315 mm Class 51
P5	741.287	741.187	18.752	315 mm Class 51
P6	741.137	740.921	41.832	315 mm Class 51
P7	740.196	739.812	75.672	315 mm Class 51
P8	739.233	738.933	58.752	315 mm Class 51
P9	738.788	738.691	18.197	315 mm Class 51
P10	737.658	737.256	79.308	315 mm Class 51
P11	736.663	736.263	78.753	315 mm Class 51
P12	736.213	736.113	18.752	315 mm Class 51
P13	736.063	735.763	58.752	315 mm Class 51
P14	735.713	735.413	58.752	315 mm Class 51
P15	735.363	735.211	29.091	315 mm Class 51

**BENCH MARKS**

NAME	YLo	XLo	Z
BM16	-89 263.067	3 349 399.099	738.264
BM17	-88 514.933	3 349 456.960	752.024

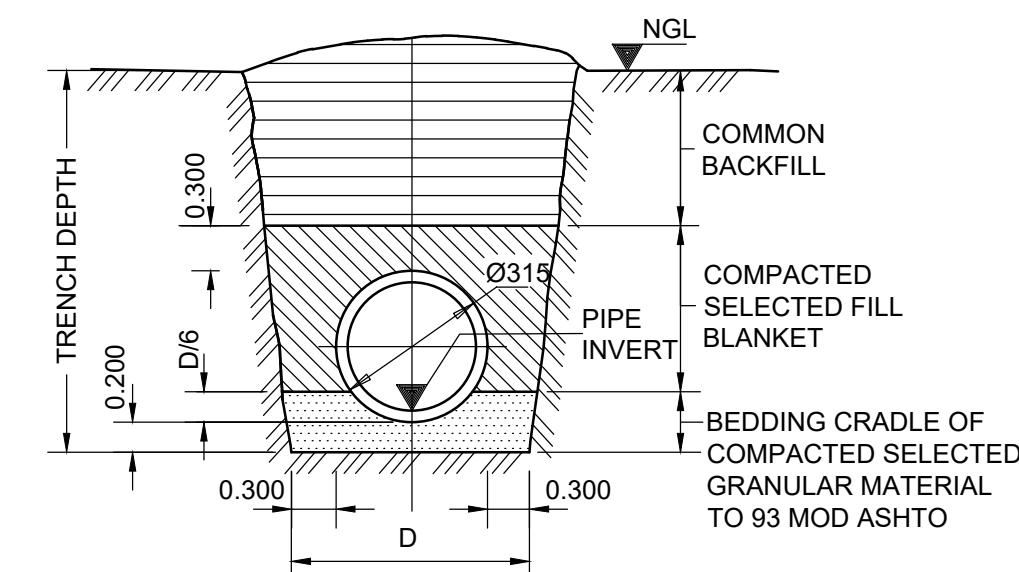

**SECTION 01-01 - POSITION OF PIPELINE IN SERVITUDE STRIP**  
N.T.S

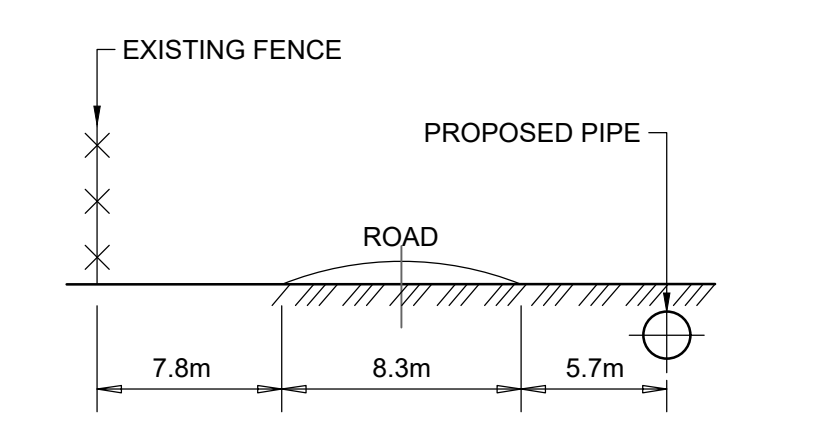

**SECTION 02-02 - POSITION OF PIPELINE IN SERVITUDE STRIP**  
N.T.S

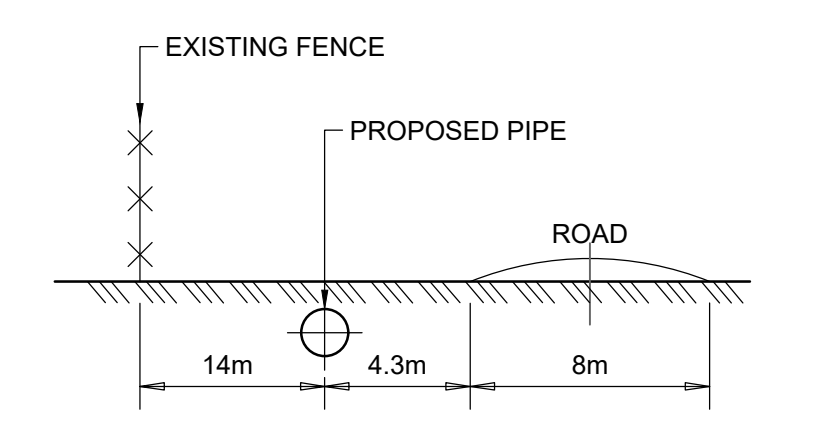

**SECTION 02-02 - POSITION OF PIPELINE IN SERVITUDE STRIP**  
N.T.S

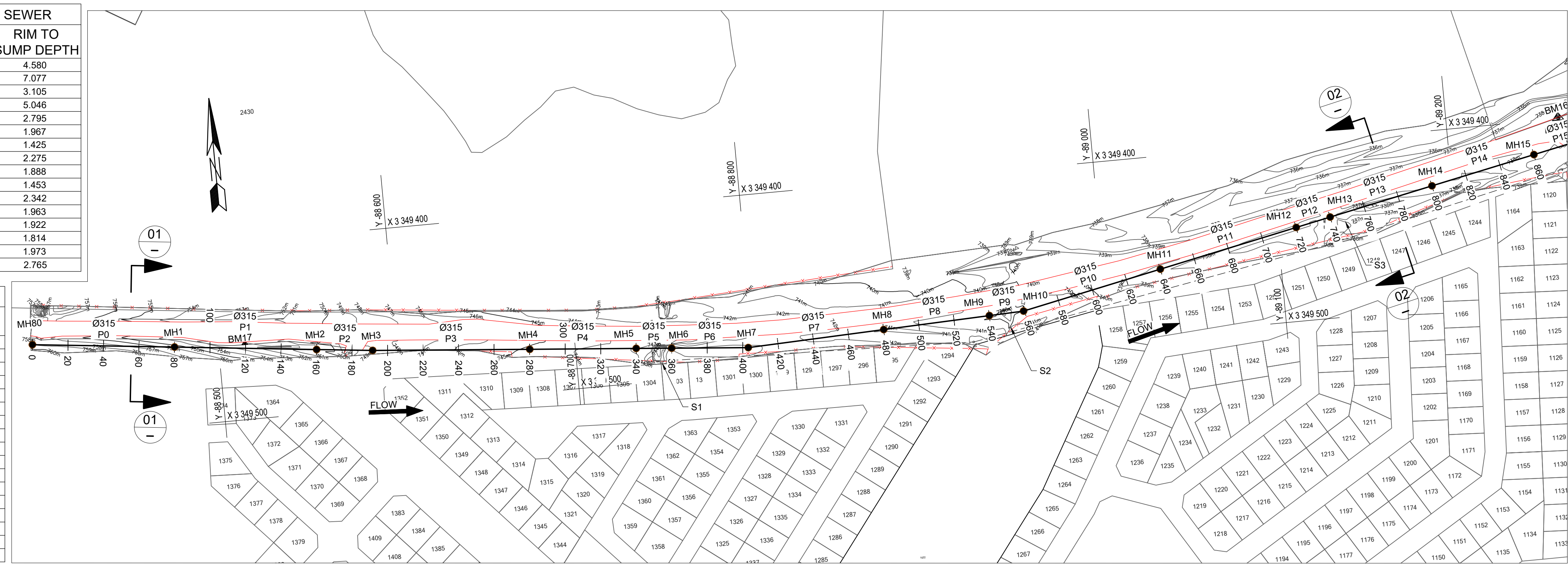
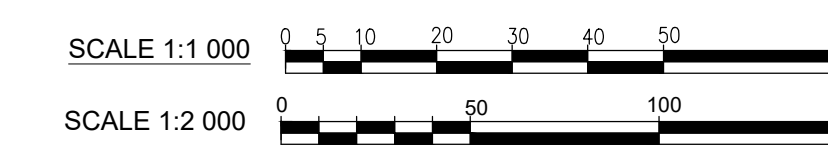

**NOTES:**

- THIS DESIGN WAS ENGINEERED BY : ZIMILE CONSULTING ENGINEERS
- THESE DRAWINGS MUST BE READ IN CONJUNCTION WITH THE SANS AND PROJECT SPECIFICATIONS.
- ALL SETTING OUT AND DIMENSIONS MUST BE CONFIRMED AND APPROVED ON SITE
- ALL CONSTRUCTION TO BE DONE IN ACCORDANCE WITH THE SANS 1200 AND PROJECT SPECIFICATIONS.
- ALL MATERIAL AND WORKMANSHIP MUST COMPLY WITH THE REQUIREMENTS OF THE LATEST RELEVANT SANS AND PROJECT SPECIFICATIONS
- THE CONTRACTOR SHALL REPORT ANY DISCREPANCIES TO THE ENGINEER WITH REGARDS TO THE BOQ, DRAWINGS AND SPECIFICATION BEFORE ORDERING ANY MATERIAL.
- FINAL POSITION OF SERVICES TO BE DETERMINED ON SITE.
- THE CONTRACTOR SHALL DETERMINE THE EXACT LOCATION OF ALL POTENTIALLY CLASHING EXISTING SERVICES AND PROTECT THEM FROM DAMAGE THROUGHOUT THE DURATION OF THE WORKS
- PIPES TO BE LAID AT LEAST 1m AWAY FROM THE STAND BOUNDARIES AND 1m PWC FROM THE ROAD EDGE
- ALL SEWER PIPES ARE TO BE uPVC CLASS 51 MANUFACTURED AS PER SANS 966

**LEGEND**

- SITE BOUNDARY
- PROPOSED SEWER PIPELINE
- EXISTING SEWER PIPELINE
- PIPE MATERIAL & CLASS
- PROPOSED MANHOLES
- FUTURE GRAVITY OUTFALL
- BENCH MARK
- FENCE MARK
- TREES
- ROAD
- CONTOURS
- EXISTING CULVERTS
- CHAINAGE
- STREAM CROSSING
- ROAD CROSSING

REFERENCE	DISTANCE (m)	GROUND LEVEL	PIPE INVERT LEVEL	SLOPE / LENGTH	HYDRAULICS
MH0	0.000	759.194	754.615	0.50% 1:200.0	15.38 0.6 10.00 0.0
MH1	80.000	755.524	750.046	0.50% 1:200.0	15.38 0.6 10.00 10.0
MH2	160.000	750.955	749.646	0.50% 1:200.0	15.38 0.6 10.00 10.0
MH3	191.603	749.000	747.691	0.50% 1:200.0	15.38 0.6 10.00 0.0
MH4	280.000	744.821	743.954	0.50% 1:200.0	15.38 0.6 10.00 0.0
MH5	340.000	743.034	742.025	0.50% 1:200.0	15.38 0.6 10.00 10.0
MH6	360.000	742.496	741.287	0.50% 1:200.0	15.38 0.6 10.00 10.0
MH7	403.080	742.471	740.921	0.50% 1:200.0	15.38 0.6 10.00 10.0
MH8	480.000	741.121	739.812	0.50% 1:200.0	15.38 0.6 10.00 10.0
MH9	540.000	740.242	739.233	0.50% 1:200.0	15.38 0.6 10.00 10.0
MH10	599.445	740.000	739.233	0.50% 1:200.0	15.38 0.6 10.00 10.0
MH11	640.000	738.565	737.256	0.50% 1:200.0	15.38 0.6 10.00 10.0
MH12	720.000	737.571	736.663	0.50% 1:200.0	15.38 0.6 10.00 10.0
MH13	740.000	737.831	736.063	0.50% 1:200.0	15.38 0.6 10.00 10.0
MH14	800.000	737.613	735.713	0.50% 1:200.0	15.38 0.6 10.00 10.0
MH15	860.000	738.127	735.413	0.50% 1:200.0	15.38 0.6 10.00 10.0
MH16	890.339	737.212	735.211	0.50% 1:200.0	15.38 0.6 10.00 10.0
MH17	920.000	738.490	735.013	0.50% 1:200.0	15.38 0.6 10.00 0.0
MH18	980.000	738.724	734.963	0.50% 1:200.0	15.38 0.6 10.00 0.0
MH19	1034.951	734.398	734.398	0.50% 1:200.0	15.38 0.6 10.00 10.0

**LONG SECTION NORTHERN OUTFALL CH 0.000 - CH 1000**  
HORIZONTAL SCALE - 1:1000  
VERTICAL SCALE - 1:500

**FOR TENDER PURPOSES ONLY**

DESIGNED	N. NDLOVU
DRAWN	N. STUURMAN
CHECKED	B. SEAKE
ISSUED FOR TENDER	08/07/2021
NATURE OF REVISION	DATE

**ZIMILE**  
Consulting Engineers

INTERNATIONAL BUSINESS GATEWAY OFFICE PARK  
CNR PIONEER AVENUE AND ELIZABETH MIDRIDGE PARK  
TEL: (011) 466-8576  
TEL: (011) 456-8813  
E-MAIL: info@zimile.co.za

COPYRIGHT RESERVED ©

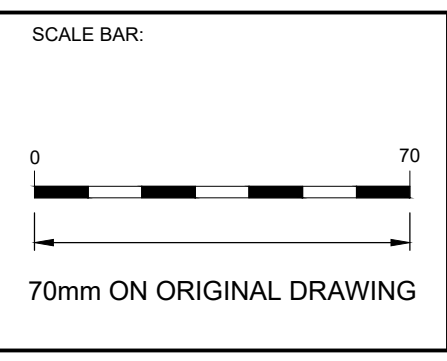

APPROVED:

B. SEAKE  
FOR ZIMILE CONSULTING ENGINEERS

DESIGNATION: TECHNICAL MANAGER

DATE: \_\_\_\_\_ SIGNATURE: \_\_\_\_\_

PROJECT: UMZIMKHULU BULK SEWER

TITLE: LONG SECTION - SHEET 1 OF 4

PRELIMINARY	TENDER	CONSTRUCTION	AS-BUILT

DATE: JULY 2021 SCALE: AS SHOWN

DRAWING No.	WT	LS	100	REVISION
J000096				A

CAD FILENAME: J:\Current Projects\WATER DEPARTMENT\J000096 - Umzimkhulu Bulk Sewer\A. Procurement Stage1 - Tender Drawings\J000096-WT-LS-001\_001\_RevA\_Sewer Long Section SH1 1-4.dwg

SIZE: A1



MH. NAME	Y	X	INVERT LEVEL	DEPTH TO SUMP
MH15	-89 247.522	3 349 418.799	738.127	2.765
MH16	-89 277.230	3 349 412.642	737.212	2.051
MH17	-89 305.614	3 349 404.035	738.488	3.525
MH18	-89 363.032	3 349 386.623	738.724	4.112
MH19	-89 415.619	3 349 370.676	739.014	4.726
MH20	-89 473.350	3 349 357.862	740.000	6.058
MH21	-89 509.702	3 349 353.314	738.870	5.161
MH22	-89 550.048	3 349 342.974	739.458	6.008
MH23	-89 617.636	3 349 340.667	738.698	5.636
MH24	-89 692.245	3 349 338.122	739.585	6.945
MH25	-89 742.963	3 349 344.969	738.050	5.755
MH26	-89 750.601	3 349 334.998	738.892	6.710
MH27	-89 730.534	3 349 309.868	738.337	6.366
MH28	-89 724.256	3 349 253.576	737.000	5.362
MH29	-89 712.474	3 349 192.083	734.557	3.513
MH30	-89 677.086	3 349 122.483	732.000	2.380
MH31	-89 667.171	3 349 104.773	730.865	3.104
MH32	-89 615.319	3 349 043.321	728.706	2.018
MH33	-89 557.596	3 348 992.255	727.650	1.397
MH34	-89 555.277	3 348 935.259	727.531	1.748
MH36	-89 305.596	3 349 404.054	738.490	1.437
MH37	-89 306.327	3 349 400.000	738.340	2.035
MH38	-89 301.333	3 349 384.498	737.533	4.229
MH39	-89 294.095	3 349 351.471	734.444	3.169
MH40	-89 334.744	3 349 275.470	732.430	2.301
MH41	-89 372.470	3 349 204.935	731.038	2.221
MH42	-89 417.364	3 349 138.707	729.726	2.320
MH43	-89 462.253	3 349 072.488	728.334	1.807

PIPE NAME	START LEVEL	END LEVEL	Dis. (m)	Diam. (mm)
P15	735.363	735.211	29.091	315 mm Class 51
P16	735.161	735.013	28.413	315 mm Class 51
P17	734.963	734.663	58.752	315 mm Class 51
P18	734.613	734.338	53.703	315 mm Class 51
P19	734.288	733.992	57.888	315 mm Class 51
P20	733.942	733.759	35.387	315 mm Class 51
P21	733.709	733.501	40.402	315 mm Class 51
P22	733.451	733.113	66.380	315 mm Class 51
P23	733.063	732.689	73.405	315 mm Class 51
P24	732.639	732.383	49.931	315 mm Class 51
P25	732.295	732.232	11.312	355 mm Class 51
P26	732.182	732.021	30.911	355 mm Class 51
P27	731.971	731.688	55.394	355 mm Class 51
P28	731.638	731.325	61.364	355 mm Class 51
P29	731.043	730.653	76.832	355 mm Class 51
P30	729.620	729.518	19.049	355 mm Class 51
P31	727.761	727.359	79.158	355 mm Class 51
P32	726.688	726.303	75.823	355 mm Class 51
P33	726.253	725.968	55.795	315 mm Class 51
P35	737.052	737.032	3.196	315 mm Class 51
P36	736.306	736.224	15.038	315 mm Class 51
P37	733.304	733.135	32.563	315 mm Class 51
P38	731.553	731.122	84.942	355 mm Class 51
P39	730.129	729.729	78.743	355 mm Class 51
P40	728.818	728.418	78.762	355 mm Class 51
P41	727.425	727.025	78.753	355 mm Class 51
P42	726.841	726.441	78.753	355 mm Class 51
P43	726.391	725.962	84.540	355 mm Class 51

NAME	YLo	XLo	Z
BM13	-89 653.847	3 349 099.132	731.550
BM14	-89 664.124	3 349 318.773	738.804
BM16	-89 263.067	3 349 399.099	738.264

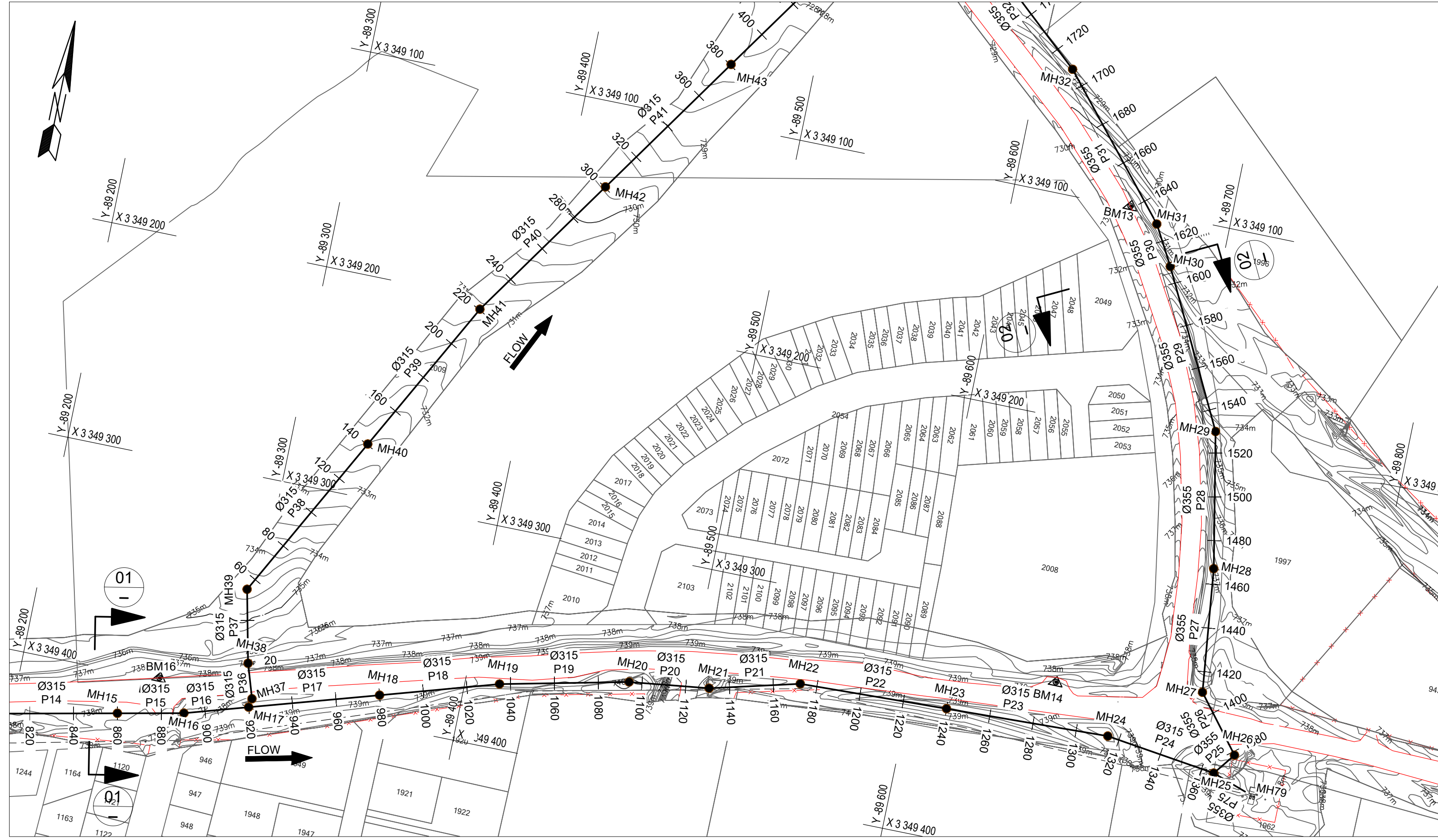

- NOTES:**
- THIS DESIGN WAS ENGINEERED BY : ZIMILE CONSULTING ENGINEERS
  - THESE DRAWINGS MUST BE READ IN CONJUNCTION WITH THE SANS AND PROJECT SPECIFICATIONS.
  - ALL SETTING OUT AND DIMENSIONS MUST BE CONFIRMED AND APPROVED ON SITE
  - ALL CONSTRUCTION TO BE DONE IN ACCORDANCE WITH THE SANS 1200 AND PROJECT SPECIFICATIONS.
  - ALL MATERIAL AND WORKMANSHIP MUST COMPLY WITH THE REQUIREMENTS OF THE LATEST RELEVANT SANS AND PROJECT SPECIFICATIONS
  - THE CONTRACTOR SHALL REPORT ANY DISCREPANCIES TO THE ENGINEER WITH REGARDS TO THE BOQ, DRAWINGS AND SPECIFICATION BEFORE ORDERING ANY MATERIAL.
  - FINAL POSITION OF SERVICES TO BE DETERMINED ON SITE.
  - THE CONTRACTOR SHALL DETERMINE THE EXACT LOCATION OF ALL POTENTIALLY CLASHING EXISTING SERVICES AND PROTECT THEM FROM DAMAGE THROUGHOUT THE DURATION OF THE WORKS
  - PIPES TO BE LAID AT LEAST 1m AWAY FROM THE STAND BOUNDARIES AND 1m AWAY FROM THE ROAD EDGE
  - ALL SEWER PIPES ARE TO BE UPVC CLASS 51 MANUFACTURED AS PER SANS 966

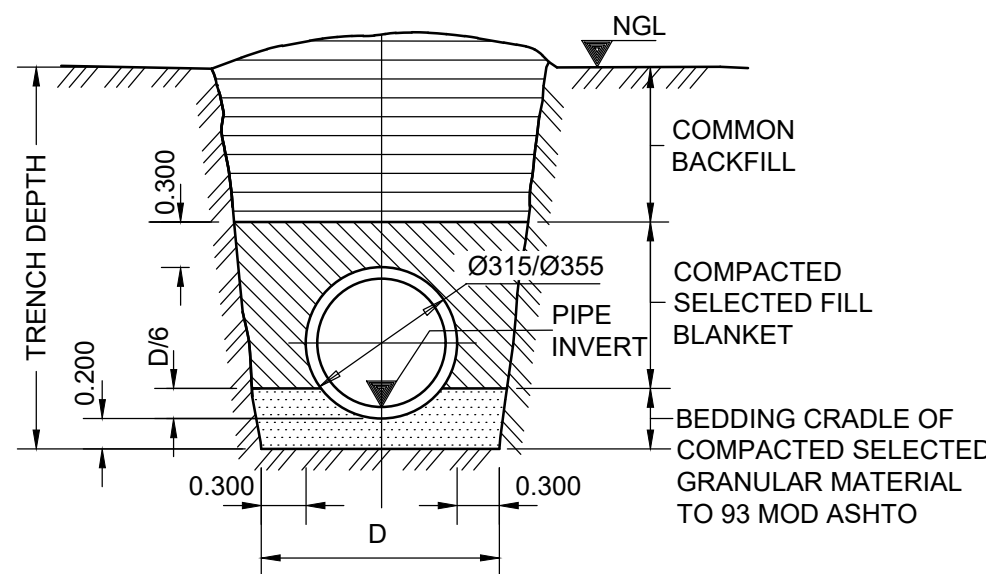

**TYPICAL TRENCH CROSS-SECTION**  
N.T.S

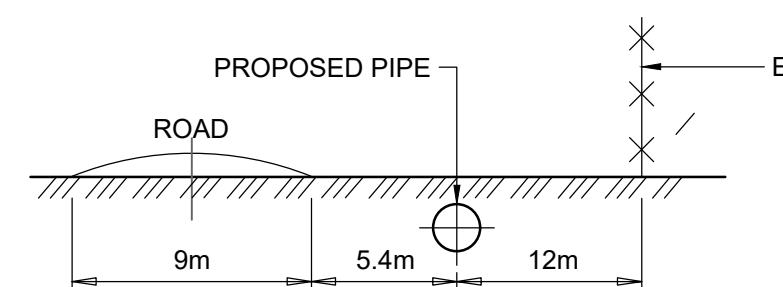

**SECTION 01-01 - POSITION OF PIPELINE IN SERVITUDE STRIP**  
N.T.S

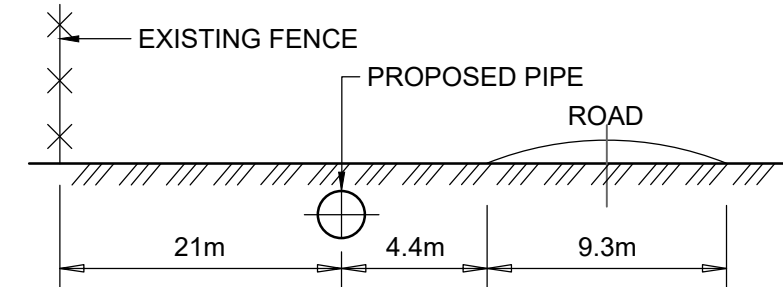

**SECTION 02-02 - POSITION OF PIPELINE IN SERVITUDE STRIP**  
N.T.S

**PLAN LAYOUT**  
SCALE 1:1500

**LEGEND**

- SITE BOUNDARY
- PROPOSED SEWER PIPELINE
- EXISTING SEWER PIPELINE
- PIPE MATERIAL & CLASS
- PROPOSED MANHOLES
- FUTURE GRAVITY OUTFALL
- BENCH MARK
- FENCE
- TREES
- ROAD
- CONTOURS
- EXISTING CULVERTS
- CHAINAGE
- STREAM CROSSING
- ROAD CROSSING
- MANHOLE

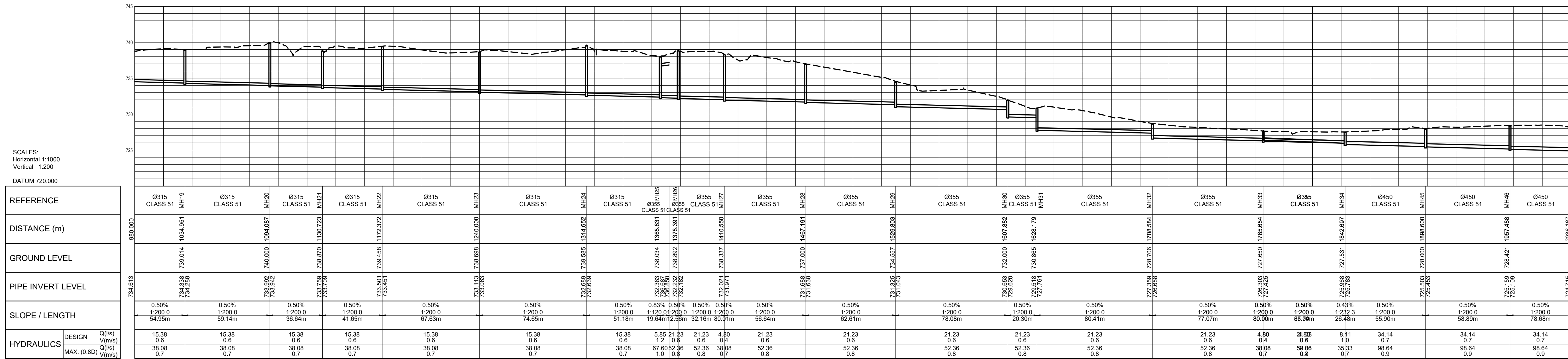

**LONG SECTION NOTHERN OUTFALL CH 1000 - CH 2000**  
HORIZONTAL SCALE - 1:1000  
VERTICAL SCALE - 1:200

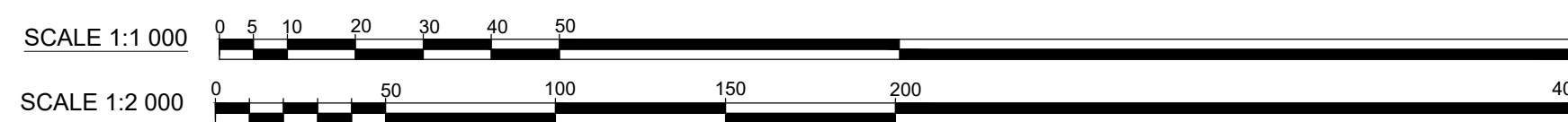

**FOR TENDER PURPOSES ONLY**

DESIGNED: N. NDLOVU DRAWN: N. STUURMAN CHECKED: B. SEAKE	<p><b>ZIMILE</b> Consulting Engineers</p> <p>INTERNATIONAL BUSINESS GATEWAY OFFICE PARK CNR PIONEER AVENUE AND ELIZABETH MIDRIDGE PARK TEL: (011) 466-8576 FAX: (011) 466-8813 E-MAIL: info@zimile.co.za COPYRIGHT RESERVED ©</p>	SCALE BAR: 70mm ON ORIGINAL DRAWING 	CLIENT: UMZIMKHULU DISTRICT MUNICIPALITY 	APPROVED: B. SEAKE FOR ZIMILE CONSULTING ENGINEERS DESIGNATION: TECHNICAL MANAGER DATE: _____ SIGNATURE: _____	PROJECT: UMZIMKHULU BULK SEWER TITLE: LONG SECTION - SHEET 2 OF 4	PROJECT PHASE PRELIMINARY [ ] TENDER [ ] CONSTRUCTION [ ] AS-BUILT [ ]			
						DATE: JULY 2021 SCALE: AS SHOWN			
						DRAWING No. J000096 WT LS 101 REVISION A CAD FILENAME: \Users\seake\Projects\Current\Projects\UMZIMKHULU DEPARTMENT\000096 - Umzimkhulu Bulk Sewer\4. Procurement Stage\1. Tender Drawing\01 - Sewer\Working Drawings\000096-WT-LS-101_001_Sewer_Sheet Long Section SH1-14.dwg SIZE A1			







**STRUCTURE LIST-NORTHERN OUTFALL SEWER**

MH. NAME	Y	X	INVERT LEVEL	DEPTH TO SUMP
MH0	-88 395.829	3 349 446.700	759.194	4.580
MH1	-88 475.343	3 349 455.510	755.524	7.077
MH2	-88 554.856	3 349 464.320	750.955	3.105
MH3	-88 586.267	3 349 467.800	749.000	5.046
MH4	-88 674.342	3 349 475.340	744.821	2.795
MH5	-88 734.123	3 349 480.458	743.034	1.967
MH6	-88 754.050	3 349 482.163	742.496	1.425
MH7	-88 796.973	3 349 485.838	742.471	2.275
MH8	-88 873.836	3 349 482.864	741.121	1.888
MH9	-88 933.791	3 349 480.545	740.242	1.453
MH10	-88 953.221	3 349 479.793	740.000	2.342
MH11	-89 032.100	3 349 463.445	738.565	1.963
MH12	-89 110.435	3 349 447.210	737.571	1.922
MH13	-89 130.019	3 349 443.152	737.831	1.814
MH14	-89 188.771	3 349 430.975	737.613	1.973
MH15	-89 247.522	3 349 418.799	738.127	2.765

**PIPE LIST-NORTHERN OUTFALL SEWER**

NAME	START LEVEL	END LEVEL	Dis. (m)	Diam. (mm)
P0	754.615	754.215	78.753	315 mm Class 51
P1	750.046	749.646	78.753	315 mm Class 51
P2	747.849	747.691	30.355	315 mm Class 51
P3	743.954	743.512	87.149	315 mm Class 51
P4	742.025	741.725	58.752	315 mm Class 51
P5	741.287	741.187	18.752	315 mm Class 51
P6	741.137	740.921	41.832	315 mm Class 51
P7	740.196	739.812	75.672	315 mm Class 51
P8	739.233	738.933	58.752	315 mm Class 51
P9	738.788	738.691	18.197	315 mm Class 51
P10	737.658	737.256	79.308	315 mm Class 51
P11	736.663	736.263	78.753	315 mm Class 51
P12	736.213	736.113	18.752	315 mm Class 51
P13	736.063	735.763	58.752	315 mm Class 51
P14	735.713	735.413	58.752	315 mm Class 51
P15	735.363	735.211	29.091	315 mm Class 51

**BENCH MARKS**

NAME	YLo	XLo	Z
BM16	-89 263.067	3 349 399.099	738.264
BM17	-88 514.933	3 349 456.960	752.024

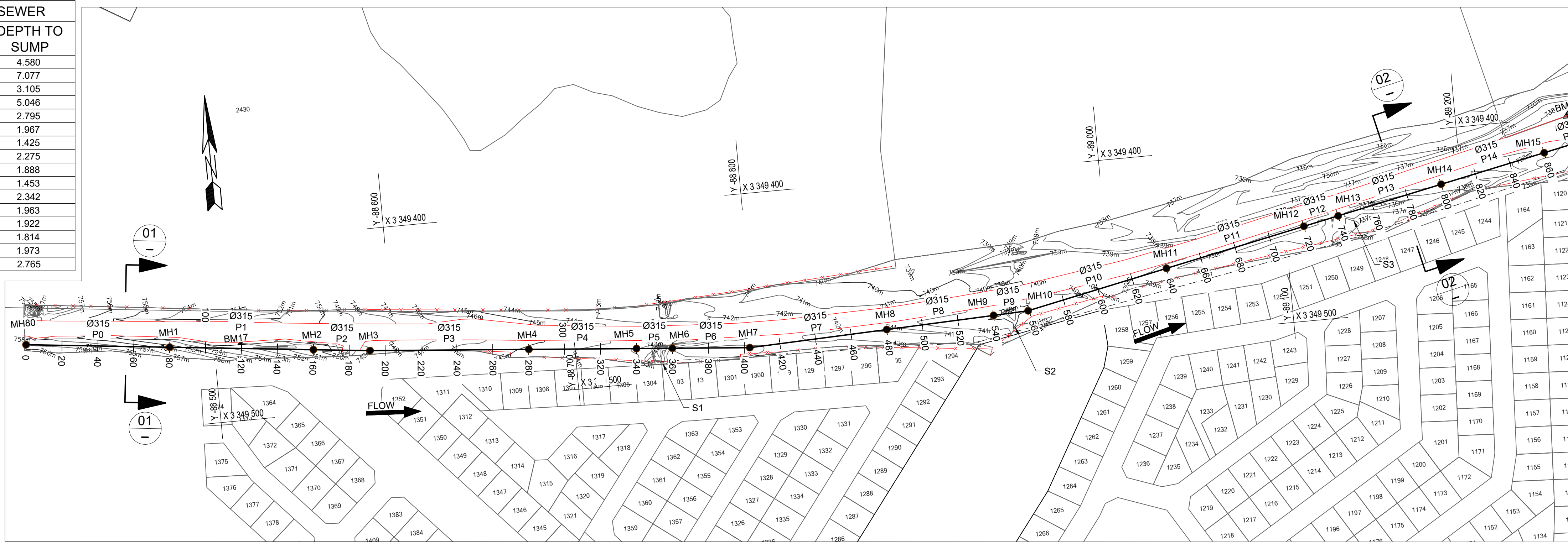

**NOTES:**

- THIS DESIGN WAS ENGINEERED BY : ZIMILE CONSULTING ENGINEERS
- THESE DRAWINGS MUST BE READ IN CONJUNCTION WITH THE SANS AND PROJECT SPECIFICATIONS.
- ALL SETTING OUT AND DIMENSIONS MUST BE CONFIRMED AND APPROVED ON SITE
- ALL CONSTRUCTION TO BE DONE IN ACCORDANCE WITH THE SANS 1200 AND PROJECT SPECIFICATIONS.
- ALL MATERIAL AND WORKMANSHIP MUST COMPLY WITH THE REQUIREMENTS OF THE LATEST RELEVANT SANS AND PROJECT SPECIFICATIONS
- THE CONTRACTOR SHALL REPORT ANY DISCREPANCIES TO THE ENGINEER WITH REGARDS TO THE BOQ, DRAWINGS AND SPECIFICATION BEFORE ORDERING ANY MATERIAL.
- FINAL POSITION OF SERVICES TO BE DETERMINED ON SITE.
- THE CONTRACTOR SHALL DETERMINE THE EXACT LOCATION OF ALL POTENTIALLY CLASHING EXISTING SERVICES AND PROTECT THEM FROM DAMAGE THROUGHOUT THE DURATION OF THE WORKS
- PIPES TO BE LAID AT LEAST 1m AWAY FROM THE STAND BOUNDARIES AND 1m PWC FROM THE ROAD EDGE
- ALL SEWER PIPES ARE TO BE uPVC CLASS 51 MANUFACTURED AS PER SANS 966

**LEGEND**

- SITE BOUNDARY
- PROPOSED SEWER PIPELINE
- EXISTING SEWER PIPELINE
- PIPE MATERIAL & CLASS
- PROPOSED MANHOLES
- FUTURE GRAVITY OUTFALL
- BENCH MARK
- FENCE
- TREES
- ROAD
- CONTOURS
- EXISTING CULVERTS
- CHAINAGE
- STREAM CROSSING
- ROAD CROSSING
- MANHOLE

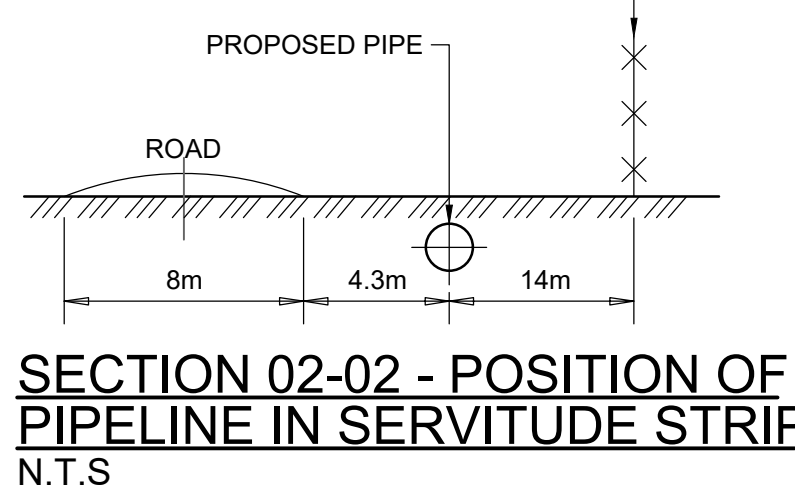
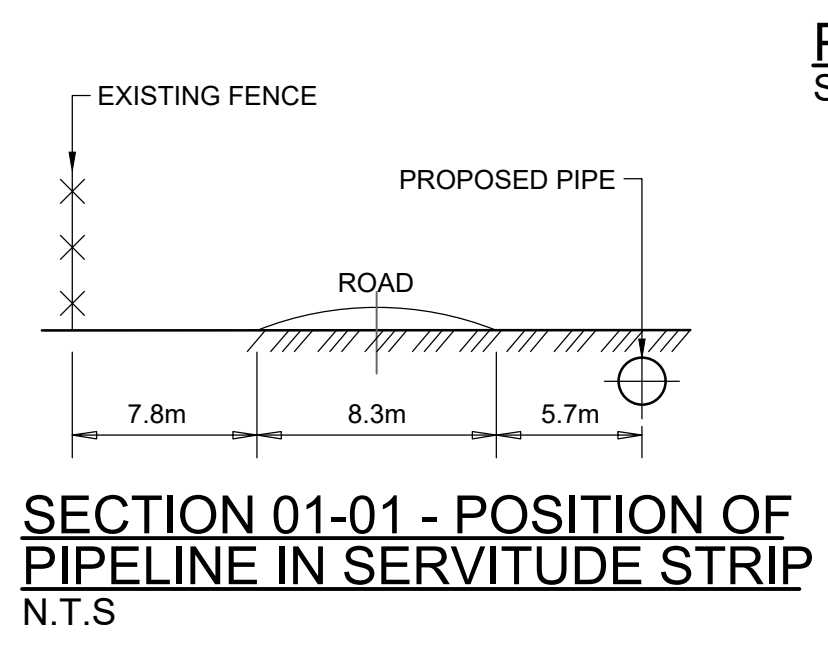
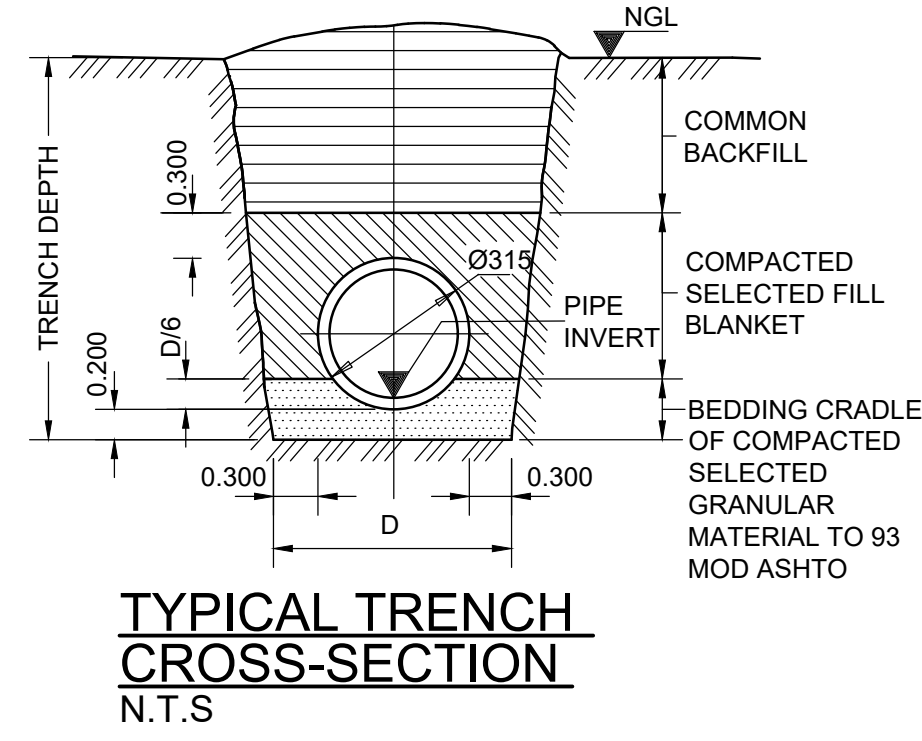

**PLAN LAYOUT**  
SCALE 1:1500

**SECTION 01-01 - POSITION OF PIPELINE IN SERVITUDE STRIP**  
N.T.S

**SECTION 02-02 - POSITION OF PIPELINE IN SERVITUDE STRIP**  
N.T.S

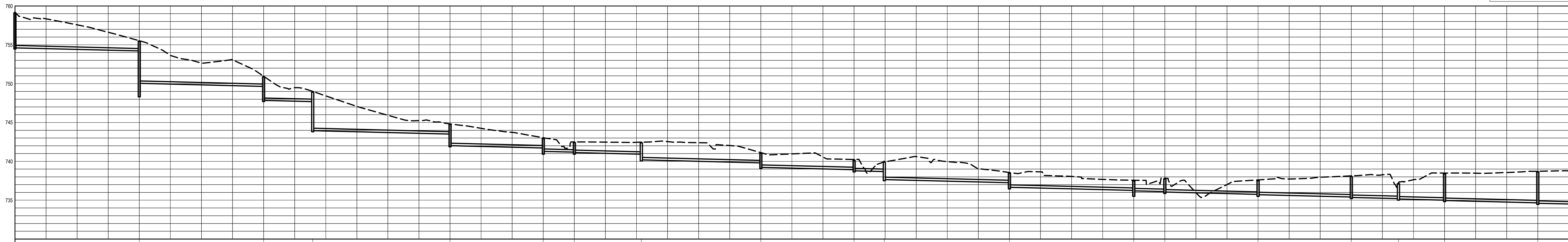

SCALES:  
Horizontal 1:1000  
Vertical 1:200  
DATUM 730.000

REFERENCE	0315 CLASS 51	MH1	0315 CLASS 51	MH2	0315 CLASS 51	MH3	0315 CLASS 51	MH4	0315 CLASS 51	MH5	0315 CLASS 51	MH6	0315 CLASS 51	MH7	0315 CLASS 51	MH8	0315 CLASS 51	MH9	0315 CLASS 51	MH10	0315 CLASS 51	MH11	0315 CLASS 51	MH12	0315 CLASS 51	MH13	0315 CLASS 51	MH14	0315 CLASS 51	MH15	0315 CLASS 51	MH16	0315 CLASS 51	MH17	0315 CLASS 51	MH18	0315 CLASS 51	
DISTANCE (m)	0.000		80.000		160.000		240.000		320.000		400.000		480.000		560.000		640.000		720.000		800.000		880.000		960.000		1040.000		1120.000		1200.000		1280.000		1360.000			
GROUND LEVEL	759.194		755.524		750.955		744.821		743.034		742.496		742.471		741.121		738.565		737.571		737.831		737.613		737.212		738.127		735.413		735.211		735.923		738.488		738.264	
PIPE INVERT LEVEL	754.615		750.046		747.849		743.954		742.025		741.287		740.921		740.196		739.233		738.788		737.658		736.663		736.213		736.063		735.713		735.363		735.211		735.363		735.363	
SLOPE / LENGTH	0.50% 1:200.0 80.00m		0.50% 1:200.0 80.00m		0.50% 1:200.0 31.60m		0.50% 1:200.0 88.40m		0.50% 1:200.0 60.00m		0.50% 1:200.0 20.00m		0.50% 1:200.0 43.08m		0.50% 1:200.0 76.92m		0.50% 1:200.0 60.00m		0.50% 1:200.0 80.56m		0.50% 1:200.0 20.00m		0.50% 1:200.0 60.00m		0.50% 1:200.0 60.00m		0.50% 1:200.0 29.56m		0.50% 1:200.0 30.34m		0.50% 1:200.0 54.95m		0.50% 1:200.0 54.95m					
HYDRAULICS	DESIGN Q(m³/s) 15.38 MAX. (0.8D) Q(m³/s) 38.08 V(m/s) 0.7		DESIGN Q(m³/s) 15.38 MAX. (0.8D) Q(m³/s) 38.08 V(m/s) 0.7		DESIGN Q(m³/s) 15.38 MAX. (0.8D) Q(m³/s) 38.08 V(m/s) 0.7		DESIGN Q(m³/s) 15.38 MAX. (0.8D) Q(m³/s) 38.08 V(m/s) 0.7		DESIGN Q(m³/s) 15.38 MAX. (0.8D) Q(m³/s) 38.08 V(m/s) 0.7		DESIGN Q(m³/s) 15.38 MAX. (0.8D) Q(m³/s) 38.08 V(m/s) 0.7		DESIGN Q(m³/s) 15.38 MAX. (0.8D) Q(m³/s) 38.08 V(m/s) 0.7		DESIGN Q(m³/s) 15.38 MAX. (0.8D) Q(m³/s) 38.08 V(m/s) 0.7		DESIGN Q(m³/s) 15.38 MAX. (0.8D) Q(m³/s) 38.08 V(m/s) 0.7		DESIGN Q(m³/s) 15.38 MAX. (0.8D) Q(m³/s) 38.08 V(m/s) 0.7		DESIGN Q(m³/s) 15.38 MAX. (0.8D) Q(m³/s) 38.08 V(m/s) 0.7		DESIGN Q(m³/s) 15.38 MAX. (0.8D) Q(m³/s) 38.08 V(m/s) 0.7		DESIGN Q(m³/s) 15.38 MAX. (0.8D) Q(m³/s) 38.08 V(m/s) 0.7		DESIGN Q(m³/s) 15.38 MAX. (0.8D) Q(m³/s) 38.08 V(m/s) 0.7		DESIGN Q(m³/s) 15.38 MAX. (0.8D) Q(m³/s) 38.08 V(m/s) 0.7		DESIGN Q(m³/s) 15.38 MAX. (0.8D) Q(m³/s) 38.08 V(m/s) 0.7		DESIGN Q(m³/s) 15.38 MAX. (0.8D) Q(m³/s) 38.08 V(m/s) 0.7		DESIGN Q(m³/s) 15.38 MAX. (0.8D) Q(m³/s) 38.08 V(m/s) 0.7		DESIGN Q(m³/s) 15.38 MAX. (0.8D) Q(m³/s) 38.08 V(m/s) 0.7	

**LONG SECTION NOTHERN OUTFALL CH 0.000 - CH 1000**  
HORIZONTAL SCALE - 1:1000  
VERTICAL SCALE - 1:200

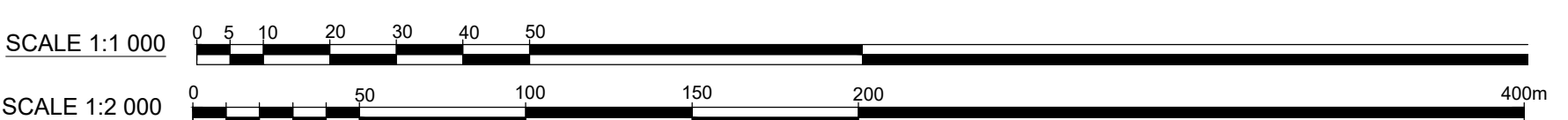

**FOR TENDER PURPOSES ONLY**

DESIGNED N. NDLOVU DRAWN N. STUURMAN CHECKED B. SEAKE	INTERNATIONAL BUSINESS GATEWAY OFFICE PARK CNR PIONEER AVENUE AND ELIZABETH MIDRIDGE PARK TEL: (011) 466-8576 FAX: (011) 456-8813 E-MAIL: info@zimile.co.za COPYRIGHT RESERVED ©	SCALE BAR: 70mm ON ORIGINAL DRAWING	CLIENT: MAMFISO DISTRICT MUNICIPALITY	APPROVED: B. SEAKE FOR ZIMILE CONSULTING ENGINEERS DESIGNATION: TECHNICAL MANAGER DATE: _____ SIGNATURE: _____	PROJECT: UMZIMKHULU BULK SEWER TITLE: LONG SECTION - SHEET 1 OF 4	PROJECT PHASE PRELIMINARY TENDER CONSTRUCTION AS-BUILT DATE: JULY 2021 SCALE: AS SHOWN			
						DRAWING No. J000096 CAD FILENAME: J000096-WT-L3-001_001_Revk_Sewer Long Section DWT 1-4.dwg NATURE OF REVISION: _____ DATE: _____	REVISION WT LS 100 A A1		



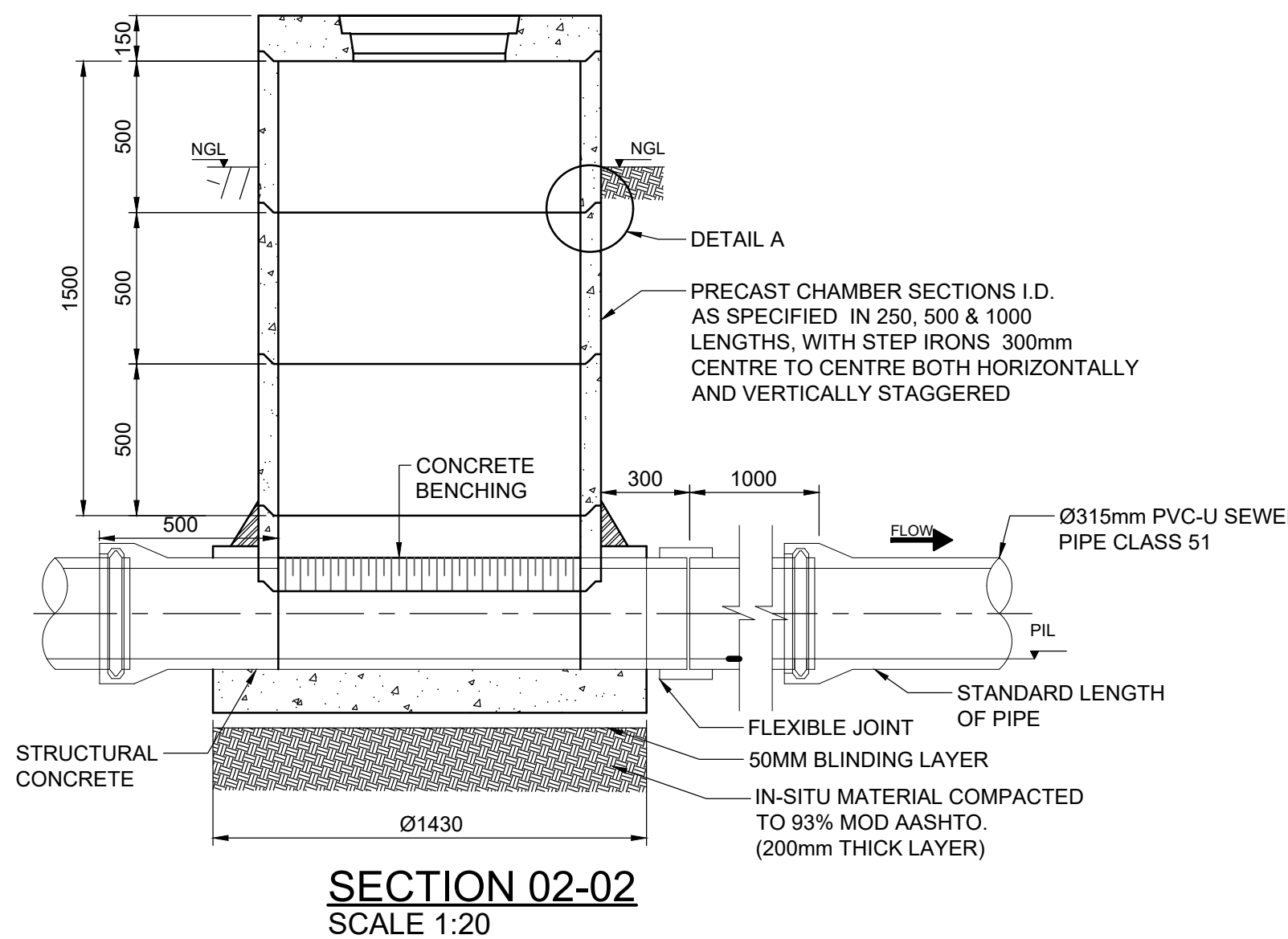
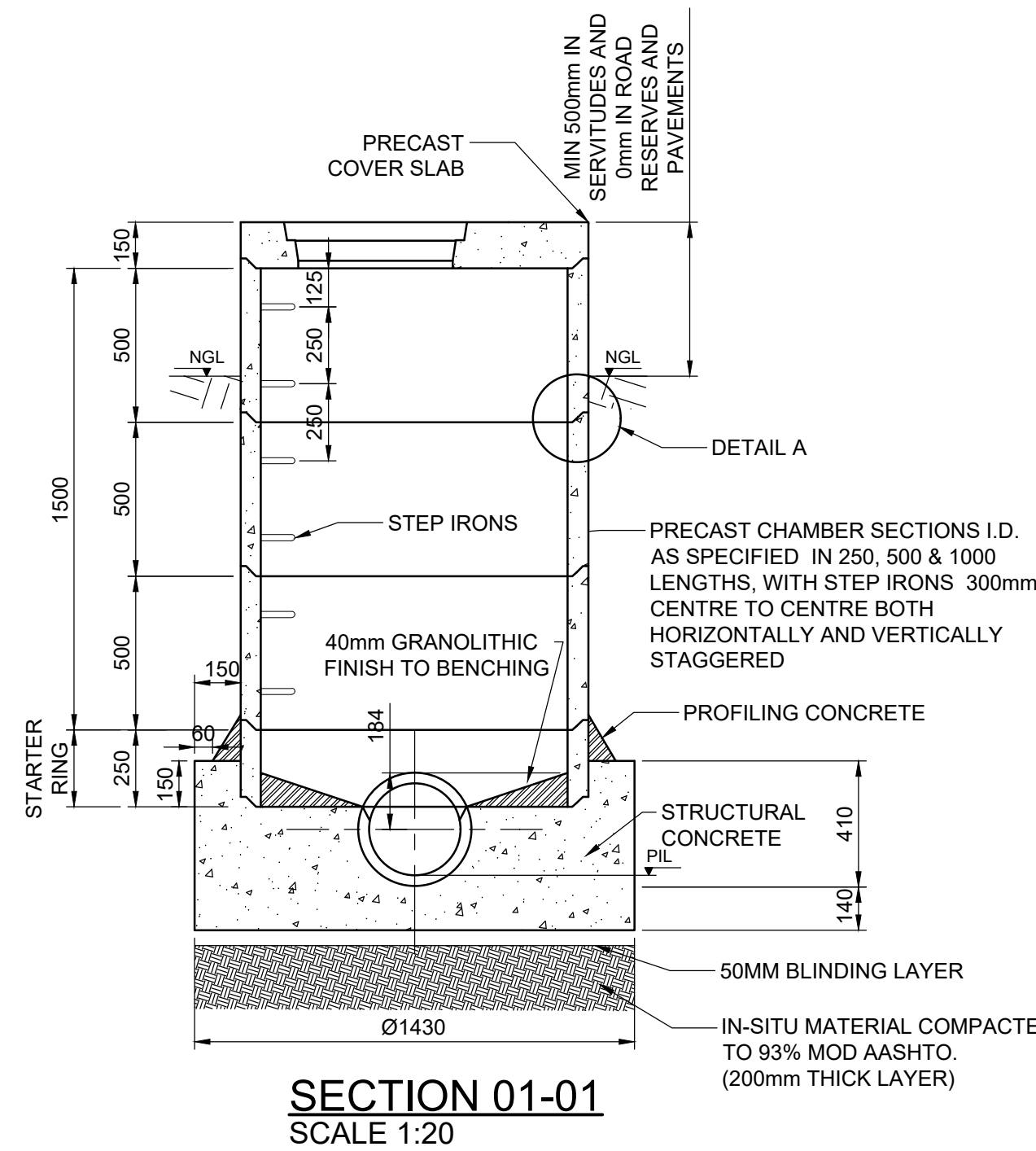
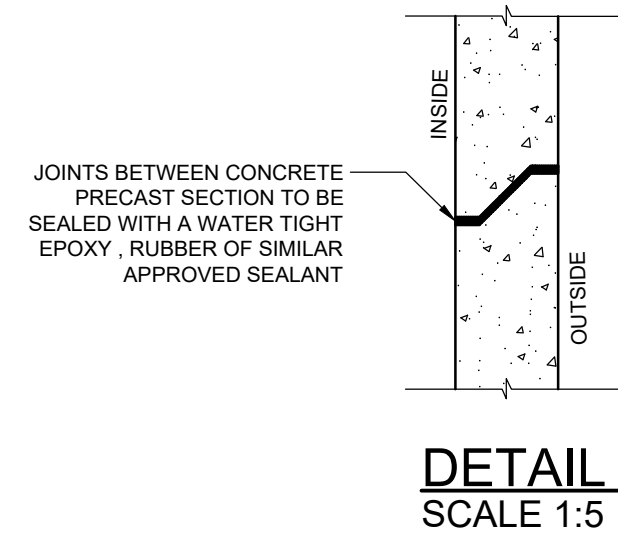
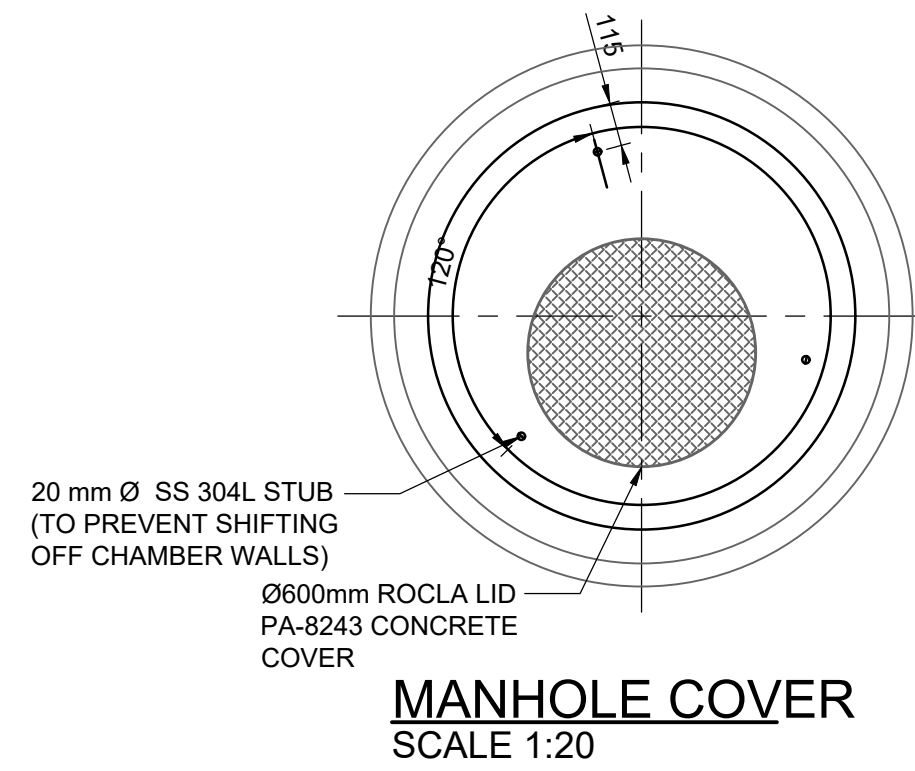
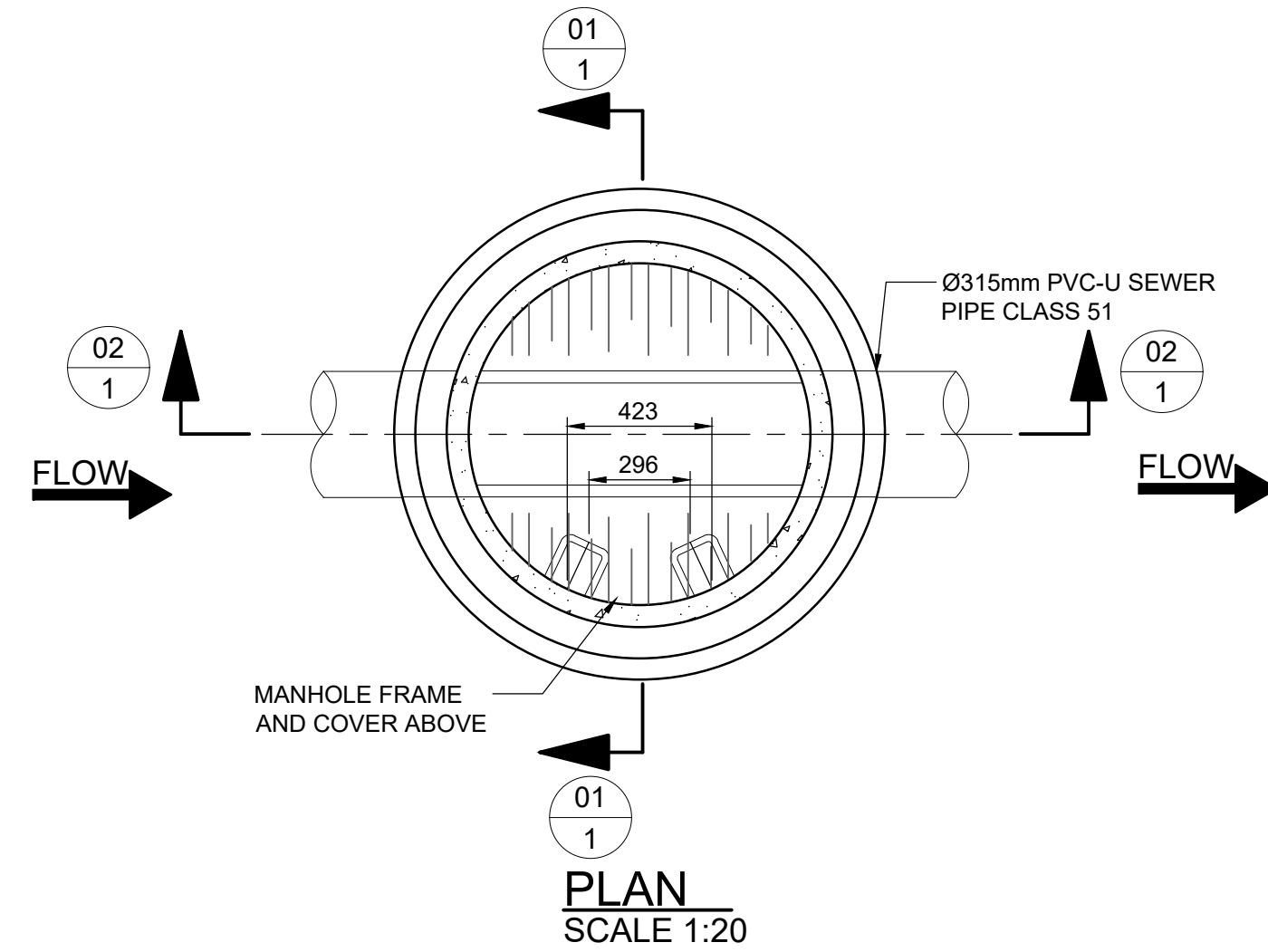

**CONCRETE:**

ALL CONCRETE WORK SHALL COMPLY WITH THE REQUIREMENTS OF SANS 1200 G.

STRIPPING TIMES OF FORMWORK AND PROPPING SHALL BE IN ACCORDANCE WITH SANS 1200G.

PROVIDE A 25x25mm CHAMFER TO ALL EXPOSED CORNERS.

ALL EXPOSED CONCRETE WORK TO BE OFF - SHUTTER FINISH.

CEMENT EXTENDERS (eg. FLY ASH) TO BE USED ONLY IF APPROVED BY THE ENGINEER.

ALL EXPOSED SLAB EDGES TO HAVE 40mm COVER.

ALL INSIDE LEVELS REFER TO CONCRETE AND NOT TO FINISHED FLOOR EXCEPT WHERE OTHERWISE INDICATED.

THE CONTRACTOR SHALL PROVIDE ALL POURING PROCEDURES, CONSTRUCTION METHODS AND POSITIONS OF CONSTRUCTION JOINTS PRIOR TO COMMENCEMENT OF PROJECT.

THE GRADES OF CONCRETE SHALL BE AS FOLLOWS:  
ALL STRUCTURAL CONCRETE CLASS 30/19  
SURFACE BEDS CLASS 30/19  
BLINDING LAYERS CLASS 10/19  
MASS CONCRETE CLASS 10/19  
PROFILING CONCRETE CLASS 30/19

CONCRETE SHALL BE CURED IN ACCORDANCE WITH SANS 1200 G.

TEMPLATES SHALL BE USED TO SET H.D.BOLTS IF POCKETS ARE NOT PROVIDED.

PANELS BETWEEN CONSTRUCTION JOINTS TO BE CAST CONSECUTIVELY

BEFORE CONCRETING TAKES PLACE ALL FOUNDATIONS ARE TO BE INSPECTED ON SITE BY THE GEOTECHNICAL ENGINEER.

THE FOUNDATION LEVELS INDICATED ARE APPROXIMATE ONLY. FINAL FOUNDING LEVELS ARE TO BE DETERMINED ON SITE BY THE GEOTECHNICAL ENGINEER.

THE DIFFERENCE BETWEEN FINAL FOUNDING LEVELS AND BOTTOM OF FOUNDATIONS SHOWN TO BE MADE UP WITH 10 MPa MASS CONCRETE.

UNLESS NOTED ALL FOUNDATIONS TO HAVE A MINIMUM OF 50mm THICK 10MPa CONCRETE BLINDING LAYER.

DURING CONSTRUCTION ALL EXCAVATIONS SHALL BE KEPT FREE OF WATER.

ALL INTERNAL AND EXPOSED CONCRETE SHALL BE SHUTTERED. IF EXTERNAL CONCRETE IS NOT SHUTTERED, AN ADDITIONAL 25mm OF CONCRETE SHALL BE ADDED TO CREATE COVER OF 75mm.

THE BOTTOM OF ALL FOUNDATIONS ARE TO BE LEVEL. IF REQUIRED, STEPS MAY BE FORMED IN ACCORDANCE WITH SANS 10400, WITH THE APPROVAL OF THE ENGINEER.

TOP OF THE EXCAVATIONS IN CUT SHALL BE RIPPED & SCARIFIED FOR 150mm AND SHALL BE COMPACTED TO 95% MOD AASHTO AT OPTIMUM MOISTURE CONTENT.

ALL LEVELS FOR FOUNDATIONS SHALL BE CHECKED FOR ITS CORRECTNESS ON SITE.

**GENERAL NOTES:**

- 1) SPACER SLABS FOR HEAVY DUTY TYPE 2A & I MANHOLE COVERS AND FRAMES TO BE 900 x 900 x 75mm WITH 5600 OPENING.
- 2) SPACER SLABS FOR MEDIUM DUTY TYPE 4 MANHOLE COVERS AND FRAMES TO BE 800 Ø x 75mm THICK WITH 5600 OPENING.
- 3) ADAPTOR SLABS FOR HEAVY DUTY TYPE 2A & I MANHOLE COVERS AND FRAMES TO BE 900 x 900 x 125mm WITH 5600 OPENING.
- 4) ADAPTOR SLABS FOR MEDIUM DUTY TYPE 4 MANHOLE COVERS AND FRAMES TO BE 8600 WITH 5600 OPENING.
- 5) OMIT ADAPTOR SLAB ON SHALLOW MANHOLES WHERE SHAFT SECTIONS ARE NOT REQUIRED.

**BRICK WORK NOTES:**

- 1) ALL PIPE CONNECTIONS TO MANHOLES TO HAVE FLEXIBLE JOINT AS PER DETAIL A.
- 2) BRICKWORK TO BE 220mm IN WIDTH (DOUBLE FACEBRICK WALLS).
- 3) ALL BRICKWORK TO BE PLASTERED INTERNALLY AND EXTERNALLY WITH 13mm 1:3 CEMENT MORTAR.
- 4) STEP IRONS TO BE PLACED AT 250mm CENTRES, STAGGERED LEFT AND RIGHT.

MH. NAME	Y	X	INVERT LEVEL	DEPTH TO SUMP
MH0	-88 395.829	3 349 446.700	759.194	4.580
MH1	-88 475.343	3 349 455.510	755.524	7.077
MH2	-88 554.856	3 349 464.320	750.955	3.105
MH3	-88 586.267	3 349 467.800	749.000	5.046
MH4	-88 674.342	3 349 475.340	744.821	2.795
MH5	-88 734.123	3 349 480.458	743.034	1.967
MH6	-88 754.050	3 349 482.163	742.496	1.425
MH7	-88 796.973	3 349 485.838	742.471	2.275
MH8	-88 873.836	3 349 482.864	741.121	1.888
MH9	-88 933.791	3 349 480.545	740.242	1.453
MH10	-88 953.221	3 349 479.793	740.000	2.342
MH11	-89 032.100	3 349 463.445	738.565	1.963
MH12	-89 110.435	3 349 447.210	737.571	1.922
MH13	-89 130.019	3 349 443.152	737.831	1.814
MH14	-89 188.771	3 349 430.975	737.613	1.973
MH15	-89 247.522	3 349 418.799	738.127	2.765
MH16	-89 277.230	3 349 412.642	737.212	2.051
MH17	-89 305.614	3 349 404.035	738.488	3.525
MH18	-89 363.032	3 349 386.623	738.724	4.112
MH19	-89 415.619	3 349 370.676	739.014	4.726
MH20	-89 473.350	3 349 357.862	740.000	6.058
MH21	-89 509.702	3 349 353.314	738.870	5.161
MH22	-89 550.048	3 349 342.974	739.458	6.008
MH23	-89 617.636	3 349 340.667	738.698	5.636
MH24	-89 692.245	3 349 338.122	739.585	6.945
MH25	-89 742.963	3 349 344.969	738.050	5.755
MH34	-89 555.277	3 348 935.259	727.531	1.748
MH36	-89 305.596	3 349 404.054	738.490	1.437
MH37	-89 306.327	3 349 400.000	738.340	2.035
MH38	-89 301.333	3 349 384.498	737.533	4.229
MH39	-89 294.095	3 349 351.471	734.444	3.169
MH40	-89 334.744	3 349 275.470	732.430	2.301
MH41	-89 372.470	3 349 204.935	731.038	2.221

PIPE NAME	START LEVEL	END LEVEL	Dis. (m)	Diam. (mm)
P0	754.615	754.215	78.753	315 mm Class 51
P1	750.046	749.646	78.753	315 mm Class 51
P2	747.849	747.691	30.355	315 mm Class 51
P3	743.954	743.512	87.149	315 mm Class 51
P4	742.025	741.725	58.752	315 mm Class 51
P5	741.287	741.187	18.752	315 mm Class 51
P6	741.137	740.921	41.832	315 mm Class 51
P7	740.196	739.812	75.672	315 mm Class 51
P8	739.233	738.933	58.752	315 mm Class 51
P9	738.788	738.691	18.197	315 mm Class 51
P10	737.658	737.256	79.308	315 mm Class 51
P11	736.663	736.263	78.753	315 mm Class 51
P12	736.213	736.113	18.752	315 mm Class 51
P13	736.063	735.763	58.752	315 mm Class 51
P14	735.713	735.413	58.752	315 mm Class 51
P15	735.363	735.211	29.091	315 mm Class 51
P16	735.161	735.013	28.413	315 mm Class 51
P17	734.963	734.663	58.752	315 mm Class 51
P18	734.613	734.338	53.703	315 mm Class 51
P19	734.288	733.992	57.888	315 mm Class 51
P20	733.942	733.759	35.387	315 mm Class 51
P21	733.709	733.501	40.402	315 mm Class 51
P22	733.451	733.113	66.380	315 mm Class 51
P23	733.063	732.689	73.405	315 mm Class 51
P24	732.639	732.383	49.931	315 mm Class 51
P33	726.253	725.968	55.795	315 mm Class 51
P35	737.052	737.032	3.196	315 mm Class 51
P36	737.306	736.224	15.038	315 mm Class 51
P37	733.304	733.135	32.563	315 mm Class 51

**FOR TENDER PURPOSES ONLY**

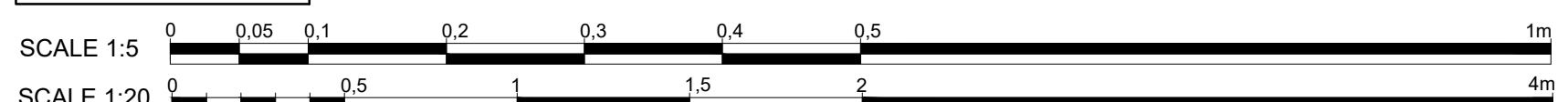
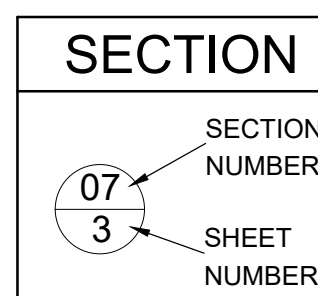

NO.	ISSUED FOR TENDER	DATE	DESIGNED	DRAWN	CHECKED
0	ISSUED FOR TENDER	14/07/2021	N. NDLOVU	D. GLOY	B. SEAKE
	NATURE OF REVISION	DATE			

DESIGNED	N. NDLOVU
DRAWN	D. GLOY
CHECKED	B. SEAKE

**ZIMILE**  
Consulting Engineers

INTERNATIONAL BUSINESS GATEWAY OFFICE PARK  
CNR PIONEER AVENUE AND ELIZABETH MIDRIDGE PARK  
TEL: (011) 466 - 8576  
FAX: (011) 466 - 8813  
E-MAIL: info@zimile.co.za  
COPYRIGHT RESERVED ©

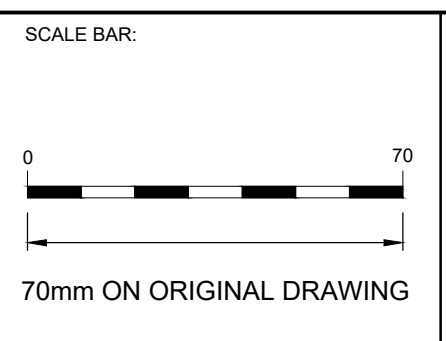

APPROVED:  
B. SEAKE  
FOR ZIMILE CONSULTING ENGINEERS

DESIGNATION: TECHNICAL MANAGER

DATE: \_\_\_\_\_ SIGNATURE: \_\_\_\_\_

PROJECT:  
**UMZIMKHULU BULK SEWER**

TITLE:  
**315MMØ PIPE TYPE 01 MANHOLE DETAILS**

PROJECT PHASE			
PRELIMINARY	TENDER	CONSTRUCTION	AS-BUILT
DATE:	JULY 2020	SCALE:	AS SHOWN
DRAWING No.	J000096	WT	DE 200
CAD FILENAME			
REVISION	A	SIZE	A1



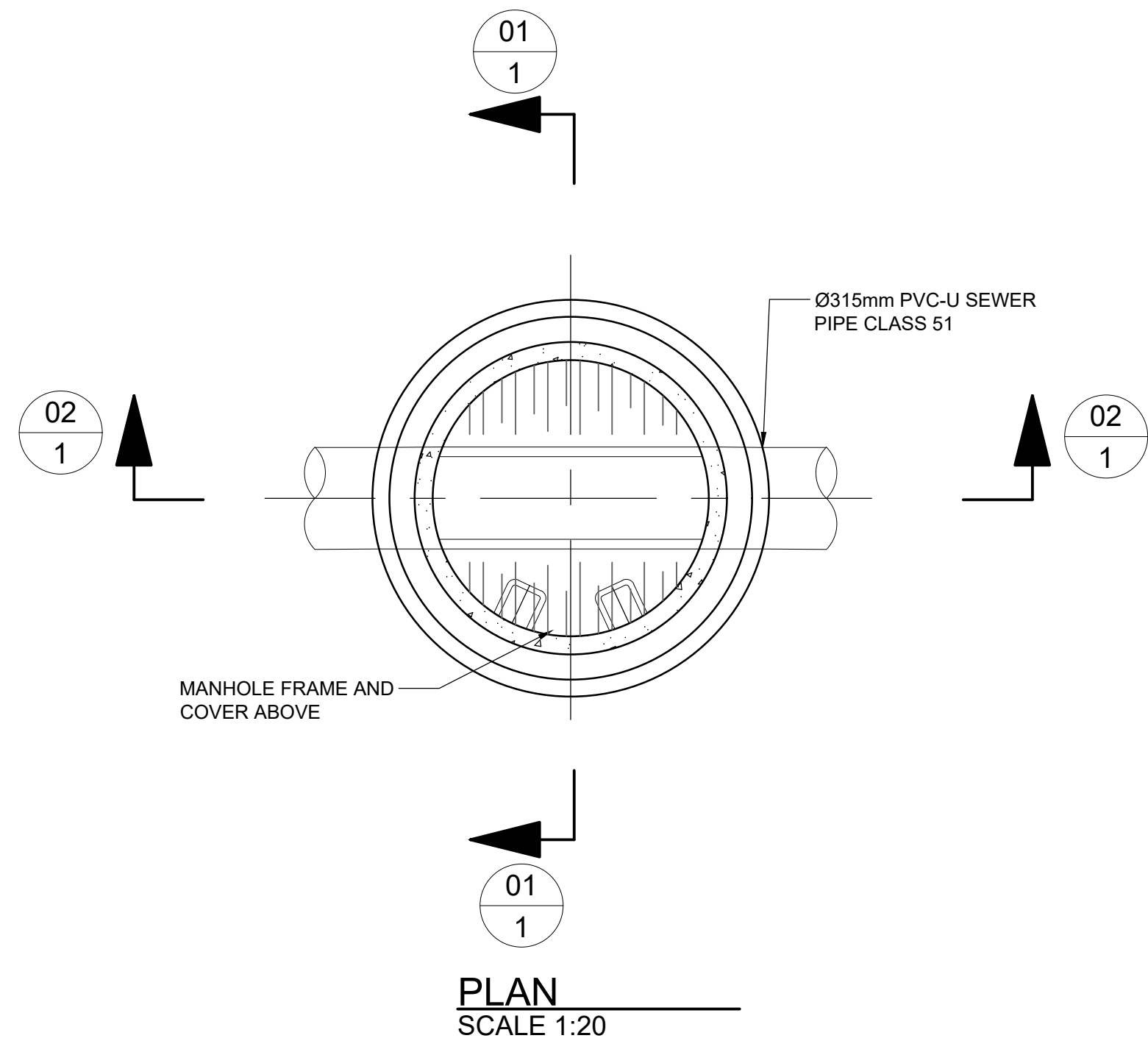

**PLAN**  
SCALE 1:20

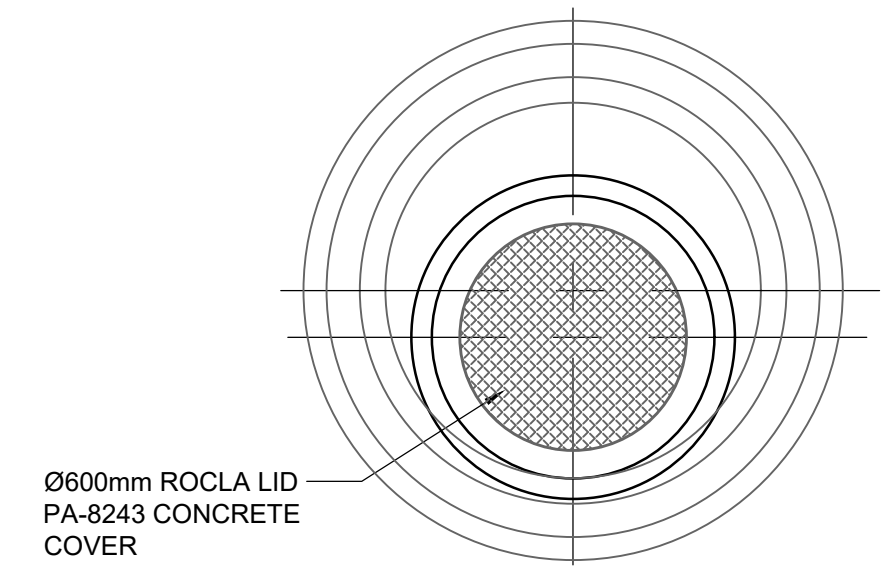

**MANHOLE COVER**  
SCALE 1:20

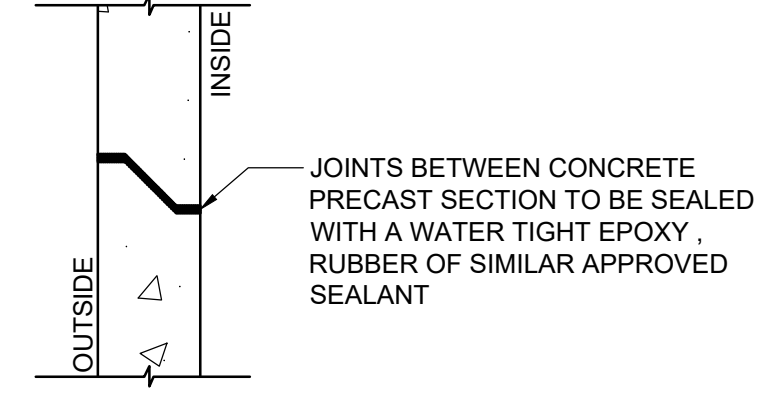

**DETAIL A**  
SCALE 1:5

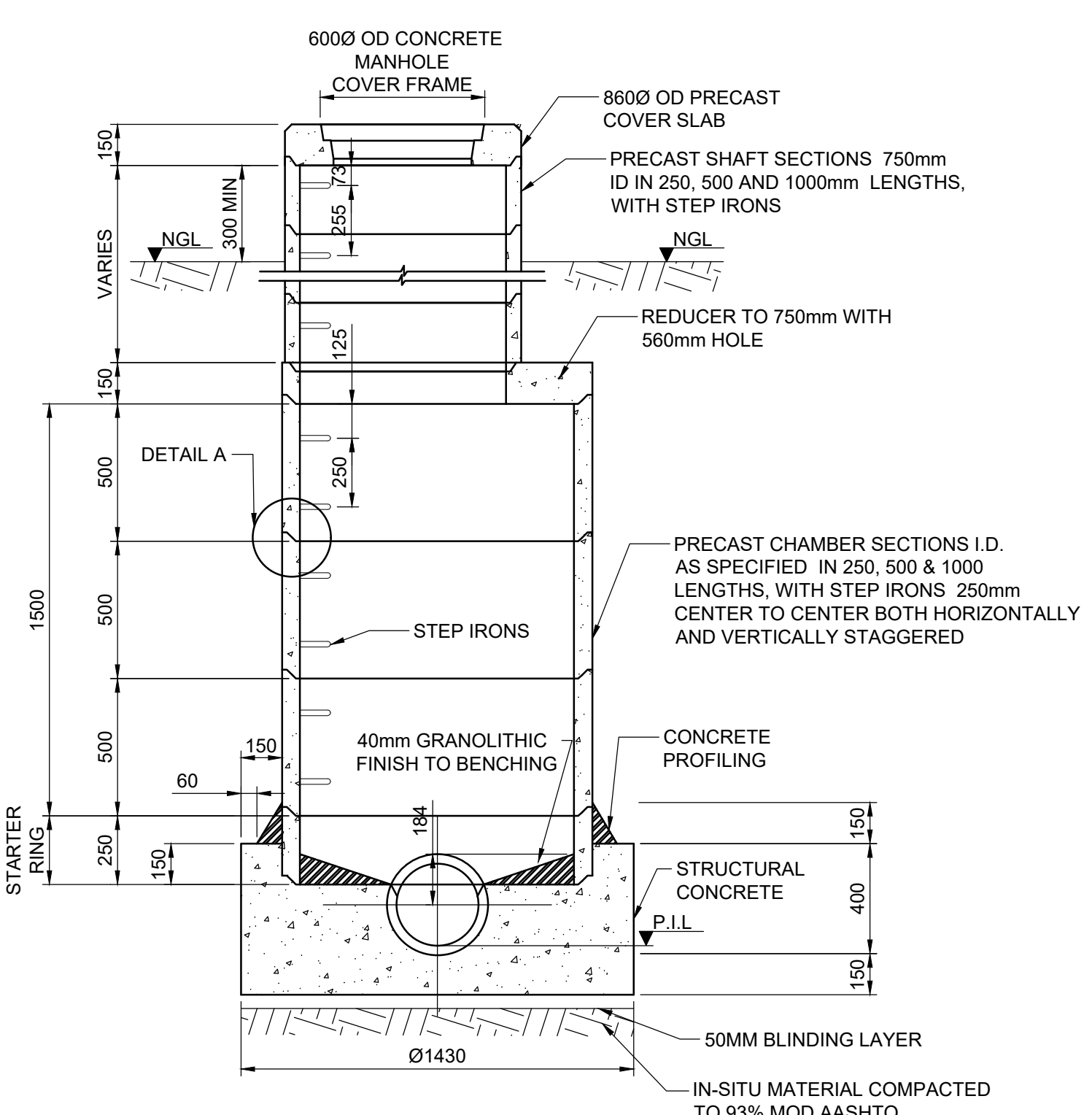

**SECTION 01-01**  
SCALE 1:20

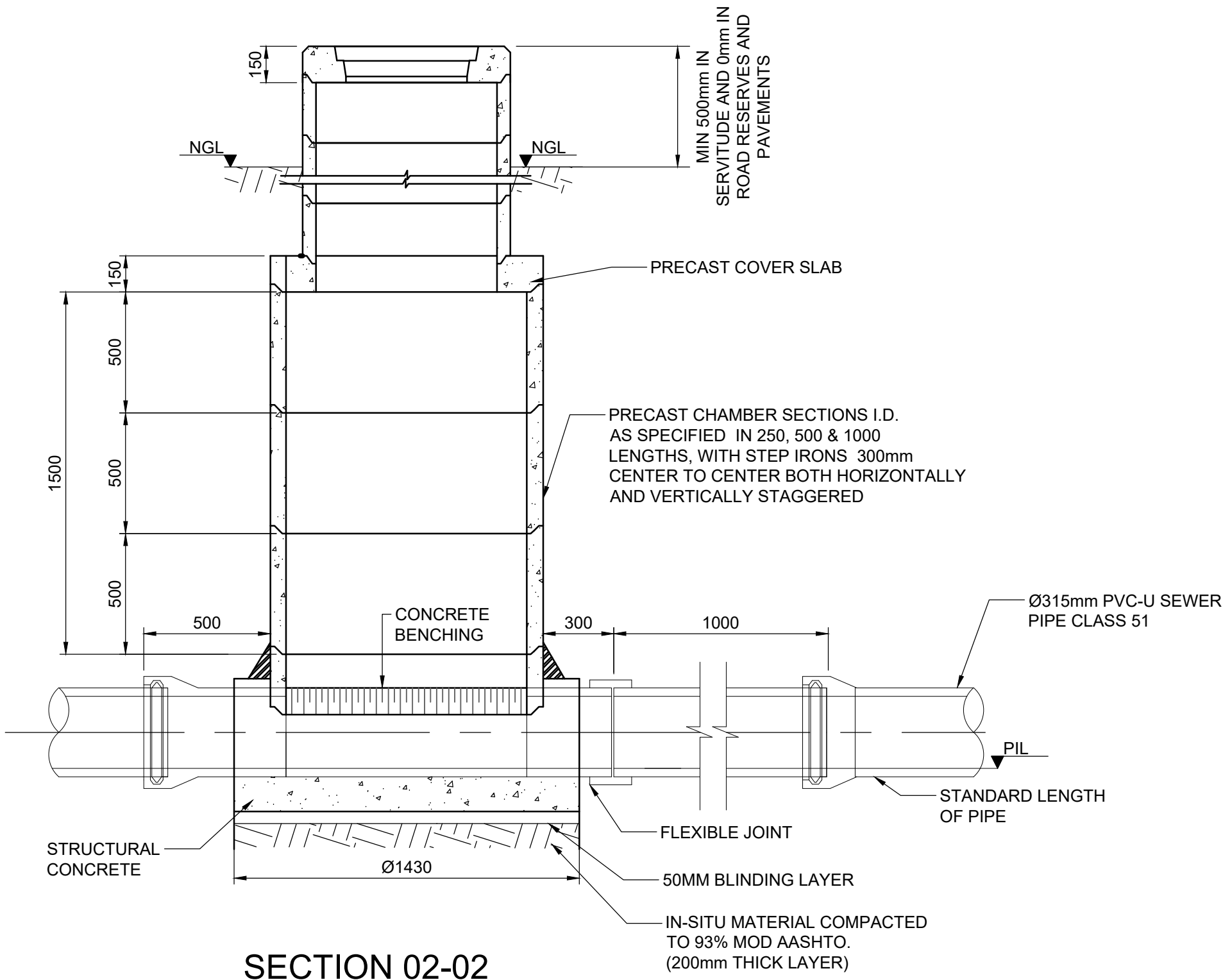

**SECTION 02-02**  
SCALE 1:20

**CONCRETE:**

ALL CONCRETE WORK SHALL COMPLY WITH THE REQUIREMENTS OF SANS 1200 G.

STRIPPING TIMES OF FORMWORK AND PROPPING SHALL BE IN ACCORDANCE WITH SANS 1200G.

PROVIDE A 25x25mm CHAMFER TO ALL EXPOSED CORNERS.

ALL EXPOSED CONCRETE TO BE OFF - SHUTTER FINISH

CEMENT EXTENDERS (eg. FLY ASH) TO BE USED ONLY IF APPROVED BY THE ENGINEER.

ALL EXPOSED SLAB EDGES TO HAVE 40mm COVER.

ALL INSIDE LEVELS REFER TO CONCRETE AND NOT TO FINISHED FLOOR EXCEPT WHERE OTHERWISE INDICATED.

THE CONTRACTOR SHALL PROVIDE ALL POURING PROCEDURES, CONSTRUCTION METHODS AND POSITIONS OF CONSTRUCTION JOINTS PRIOR TO COMMENCEMENT OF PROJECT.

THE GRADES OF CONCRETE SHALL BE AS FOLLOWS:  
ALL STRUCTURAL CONCRETE CLASS 30/19  
SURFACE BEDS CLASS 30/19  
BLINDING LAYERS CLASS 10/19  
MASS CONCRETE CLASS 10/19  
PROFILING CONCRETE CLASS 30/19

CONCRETE SHALL BE CURED IN ACCORDANCE WITH SANS 1200 G.

TEMPLATES SHALL BE USED TO SET H.D.BOLTS IF POCKETS ARE NOT PROVIDED.

PANELS BETWEEN CONSTRUCTION JOINTS TO BE CAST CONSECUTIVELY

BEFORE CONCRETING TAKES PLACE ALL FOUNDATIONS ARE TO BE INSPECTED ON SITE BY THE GEOTECHNICAL ENGINEER.

THE FOUNDATION LEVELS INDICATED ARE APPROXIMATE ONLY. FINAL FOUNDING LEVELS ARE TO BE DETERMINED ON SITE BY THE GEOTECHNICAL ENGINEER.

THE DIFFERENCE BETWEEN FINAL FOUNDING LEVELS AND BOTTOM OF FOUNDATIONS SHOWN TO BE MADE UP WITH 10 MPa MASS CONCRETE.

UNLESS NOTED ALL FOUNDATIONS TO HAVE A MINIMUM OF 50mm THICK 10MPa CONCRETE BLINDING LAYER.

DURING CONSTRUCTION ALL EXCAVATIONS SHALL BE KEPT FREE OF WATER.

ALL INTERNAL AND EXPOSED CONCRETE SHALL BE SHUTTERED. IF EXTERNAL CONCRETE IS NOT SHUTTERED, AN ADDITIONAL 25mm OF CONCRETE SHALL BE ADDED TO CREATE COVER OF 75mm.

THE BOTTOM OF ALL FOUNDATIONS ARE TO BE LEVEL. IF REQUIRED, STEPS MAY BE FORMED IN ACCORDANCE WITH SANS 10400, WITH THE APPROVAL OF THE ENGINEER.

TOP OF THE EXCAVATIONS IN CUT SHALL BE RIPPED & SCARIFIED FOR 150mm AND SHALL BE COMPACTED TO 95% MOD AASHTO AT OPTIMUM MOISTURE CONTENT.

ALL LEVELS FOR FOUNDATIONS SHALL BE CHECKED FOR ITS CORRECTNESS ON SITE.

**GENERAL NOTES:**

- 1) SPACER SLABS FOR HEAVY DUTY TYPE 2A & I MANHOLE COVERS AND FRAMES TO BE 900 x 900 x 75mm WITH 560Ø OPENING.
- 2) SPACER SLABS FOR MEDIUM DUTY TYPE 4 MANHOLE COVERS AND FRAMES TO BE 800 Ø x 75mm THICK WITH 560Ø OPENING.
- 3) ADAPTOR SLABS FOR HEAVY DUTY TYPE 2A & I MANHOLE COVERS AND FRAMES TO BE 900 x 900 x 125mm WITH 560Ø OPENING.
- 4) ADAPTOR SLABS FOR MEDIUM DUTY TYPE 4 MANHOLE COVERS AND FRAMES TO BE 860Ø WITH 560Ø OPENING.
- 5) OMIT ADAPTOR SLAB ON SHALLOW MANHOLES WHERE SHAFT SECTIONS ARE NOT REQUIRED.

**BRICK WORK NOTES:**

- 1) ALL PIPE CONNECTIONS TO MANHOLES TO HAVE FLEXIBLE JOINT AS PER DETAIL A.
- 2) BRICKWORK TO BE 220mm IN WIDTH (DOUBLE FACEBRICK WALLS).
- 3) ALL BRICKWORK TO BE PLASTERED INTERNALLY AND EXTERNALLY WITH 13mm 1:3 CEMENT MORTAR.
- 4) STEP IRONS TO BE PLACED AT 250mm CENTRES, STAGGERED LEFT AND RIGHT.

**STRUCTURE LIST-NORTHERN OUTFALL SEWER**

MH. NAME	Y	X	INVERT LEVEL	DEPTH TO SUMP
MH0	-88 395.829	3 349 446.700	759.194	4.580
MH1	-88 475.343	3 349 455.510	755.524	7.077
MH2	-88 554.856	3 349 464.320	750.955	3.105
MH3	-88 586.267	3 349 467.800	749.000	5.046
MH4	-88 674.342	3 349 475.340	744.821	2.795
MH5	-88 734.123	3 349 480.458	743.034	1.967
MH6	-88 754.050	3 349 482.163	742.496	1.425
MH7	-88 796.973	3 349 485.838	742.471	2.275
MH8	-88 873.836	3 349 482.864	741.121	1.888
MH9	-88 933.791	3 349 480.545	740.242	1.453
MH10	-88 953.221	3 349 479.793	740.000	2.342
MH11	-89 032.100	3 349 463.445	738.565	1.963
MH12	-89 110.435	3 349 447.210	737.571	1.922
MH13	-89 130.019	3 349 443.152	737.831	1.814
MH14	-89 188.771	3 349 430.975	737.613	1.973
MH15	-89 247.522	3 349 418.799	738.127	2.765
MH16	-89 277.230	3 349 412.642	737.212	2.051
MH17	-89 305.614	3 349 404.035	738.488	3.525
MH18	-89 363.032	3 349 386.623	738.724	4.112
MH19	-89 415.619	3 349 370.676	739.014	4.726
MH20	-89 473.350	3 349 357.862	740.000	6.058
MH21	-89 509.702	3 349 353.314	738.870	5.161
MH22	-89 550.048	3 349 342.974	739.458	6.008
MH23	-89 617.636	3 349 340.667	738.698	5.636
MH24	-89 692.245	3 349 338.122	739.585	6.945
MH25	-89 742.963	3 349 344.969	738.050	5.755
MH34	-89 555.277	3 348 935.259	727.531	1.748
MH36	-89 305.596	3 349 404.054	738.490	1.437
MH37	-89 306.327	3 349 400.000	738.340	2.035
MH38	-89 301.333	3 349 384.498	737.533	4.229
MH39	-89 294.095	3 349 351.471	734.444	3.169
MH40	-89 334.744	3 349 275.470	732.430	2.301
MH41	-89 372.470	3 349 204.935	731.038	2.221

**PIPE LIST-NORTHERN OUTFALL SEWER**

NAME	START LEVEL	END LEVEL	Dis. (m)	Diam. (mm)
P0	754.615	754.215	78.753	315 mm Class 51
P1	750.046	749.646	78.753	315 mm Class 51
P2	747.849	747.691	30.355	315 mm Class 51
P3	743.954	743.512	87.149	315 mm Class 51
P4	742.025	741.725	58.752	315 mm Class 51
P5	741.287	741.187	18.752	315 mm Class 51
P6	741.137	740.921	41.832	315 mm Class 51
P7	740.196	739.812	75.672	315 mm Class 51
P8	739.233	738.933	58.752	315 mm Class 51
P9	738.788	738.691	18.197	315 mm Class 51
P10	737.658	737.256	79.308	315 mm Class 51
P11	736.663	736.263	78.753	315 mm Class 51
P12	736.213	736.113	18.752	315 mm Class 51
P13	736.063	735.763	58.752	315 mm Class 51
P14	735.713	735.413	58.752	315 mm Class 51
P15	735.363	735.211	29.091	315 mm Class 51
P16	735.161	735.013	28.413	315 mm Class 51
P17	734.963	734.663	58.752	315 mm Class 51
P18	734.613	734.338	53.703	315 mm Class 51
P19	734.288	733.992	57.888	315 mm Class 51
P20	733.942	733.759	35.387	315 mm Class 51
P21	733.709	733.501	40.402	315 mm Class 51
P22	733.451	733.113	66.380	315 mm Class 51
P23	733.063	732.689	73.405	315 mm Class 51
P24	732.639	732.383	49.931	315 mm Class 51
P33	726.253	725.968	55.795	315 mm Class 51
P35	737.052	737.032	3.196	315 mm Class 51
P36	736.306	736.224	15.038	315 mm Class 51
P37	733.304	733.135	32.563	315 mm Class 51

**FOR TENDER PURPOSES ONLY**

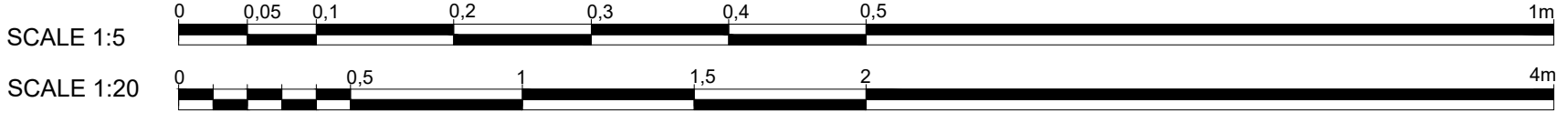
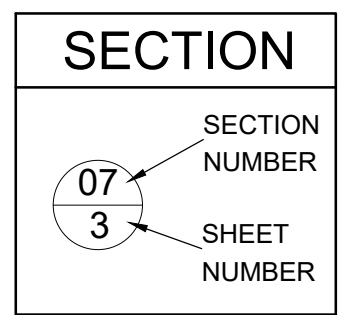

DESIGNED	N. NDLOVU	DATE	14/07/2021
DRAWN	D. GLOY	DATE	
CHECKED	B. SEAKE	DATE	

**ZIMILE Consulting Engineers**

INTERNATIONAL BUSINESS GATEWAY OFFICE PARK  
CNR PIONEER AVENUE AND ELIZABETH MIDRIDGE PARK  
TEL: (011) 466-8576  
FAX: (011) 466-8813  
E-MAIL: info@zimile.co.za

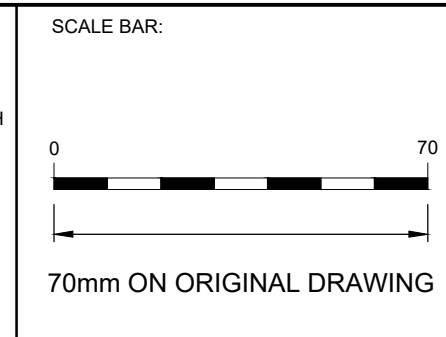

APPROVED: B. SEAKE  
FOR ZIMILE CONSULTING ENGINEERS  
DESIGNATION: TECHNICAL MANAGER  
DATE: \_\_\_\_\_ SIGNATURE: \_\_\_\_\_

PROJECT: UMZIMKHULU BULK SEWER  
TITLE: 315mmØ PIPE TYPE 02 MANHOLE DETAILS

PROJECT PHASE			
PRELIMINARY	TENDER	CONSTRUCTION	AS-BUILT
DATE: JULY 2020	SCALE: AS SHOWN		
DRAWING No. J000096	WT	DE	201
CAD FILENAME	REVISION		A1



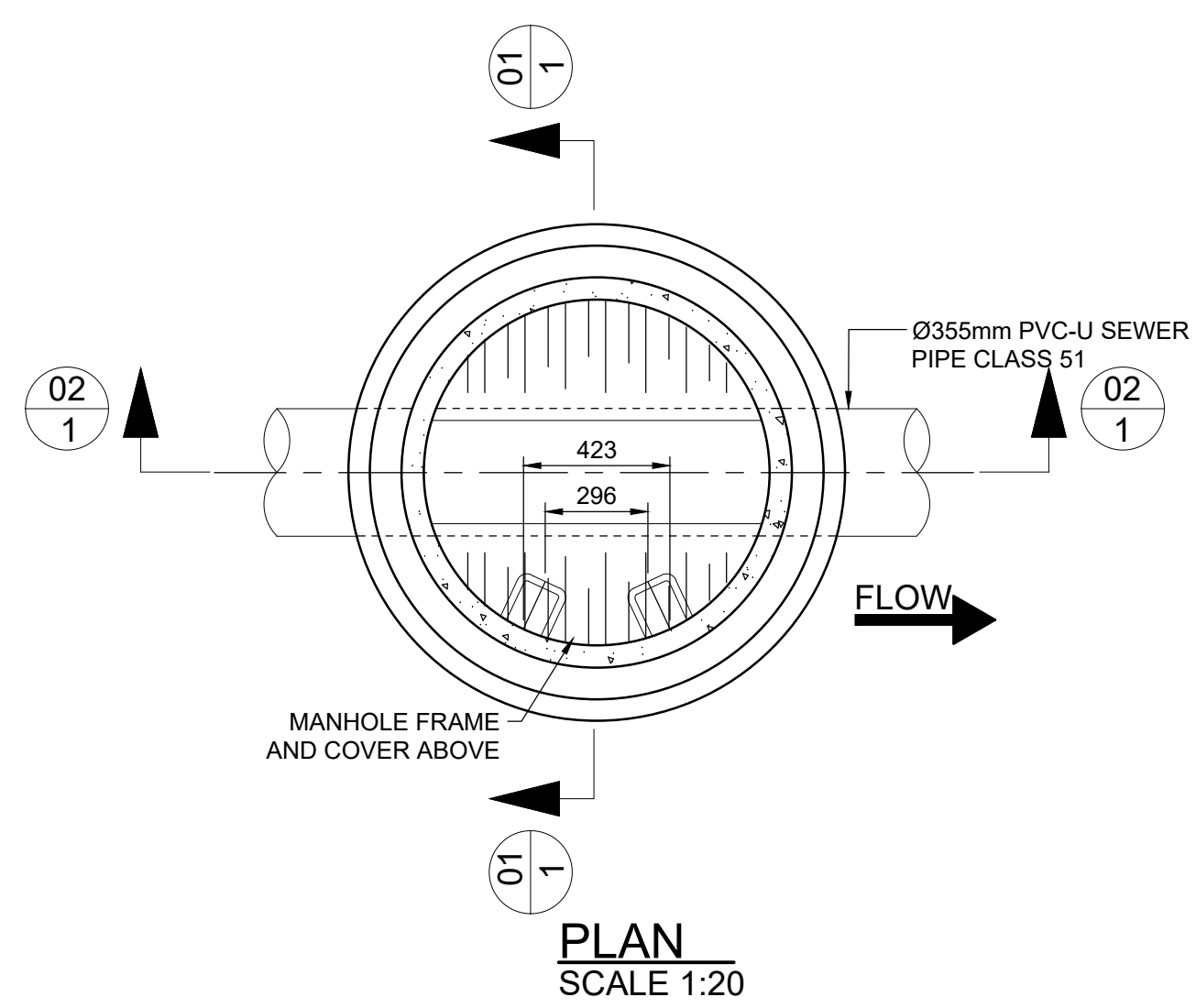

PLAN  
SCALE 1:20

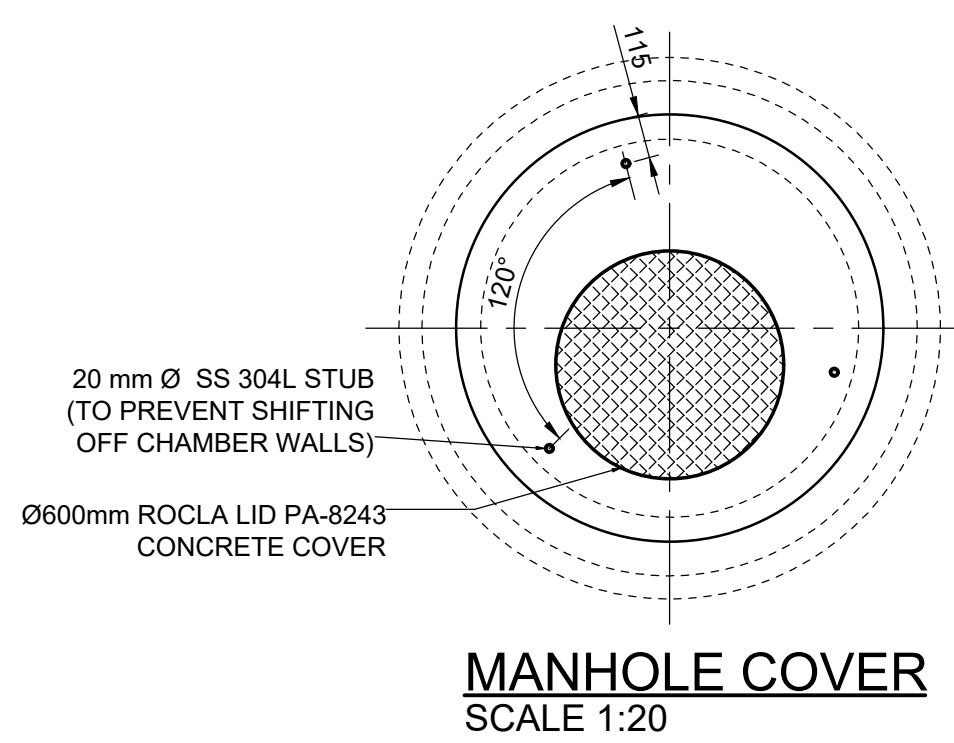

MANHOLE COVER  
SCALE 1:20

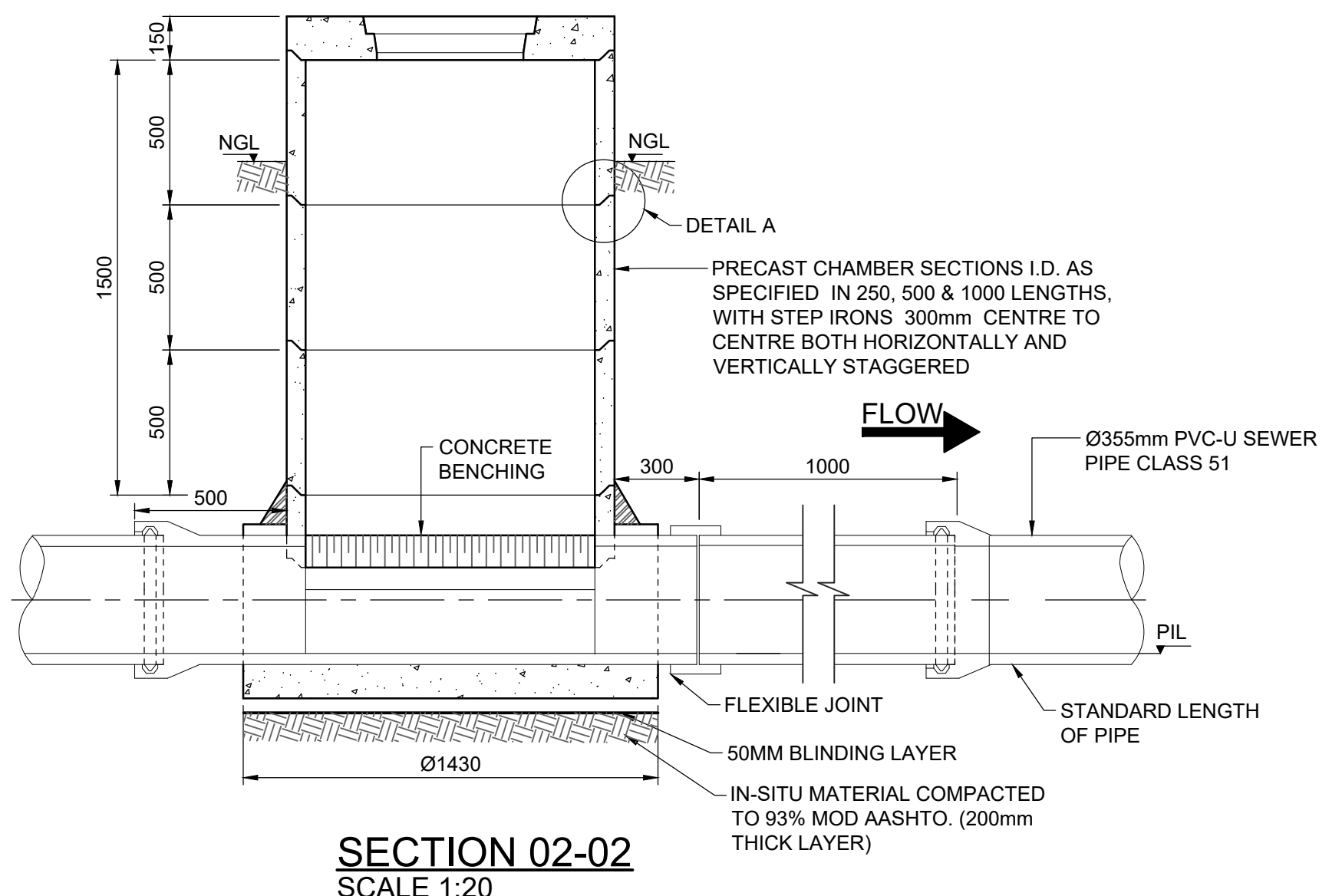

SECTION 02-02  
SCALE 1:20

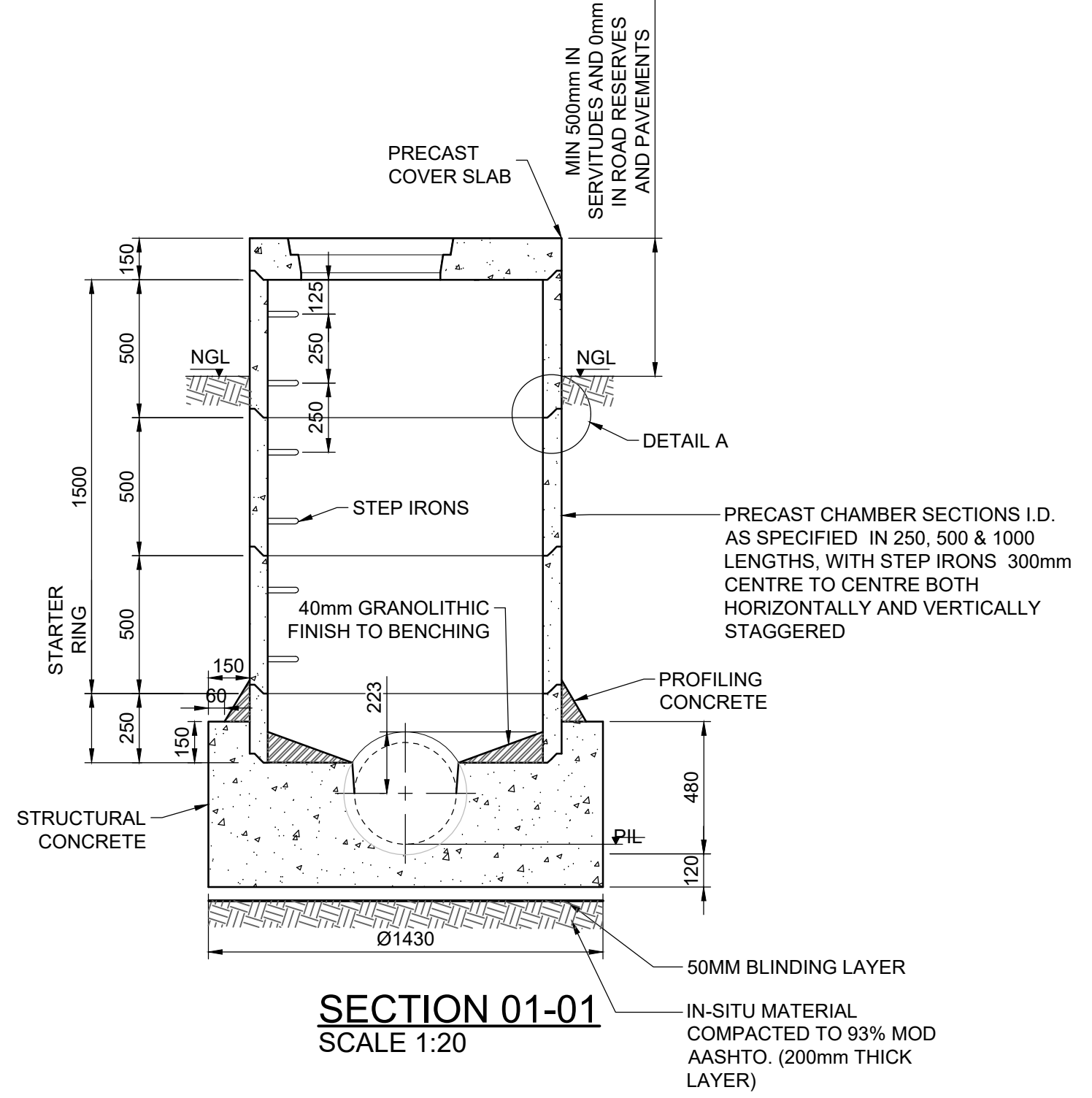

SECTION 01-01  
SCALE 1:20

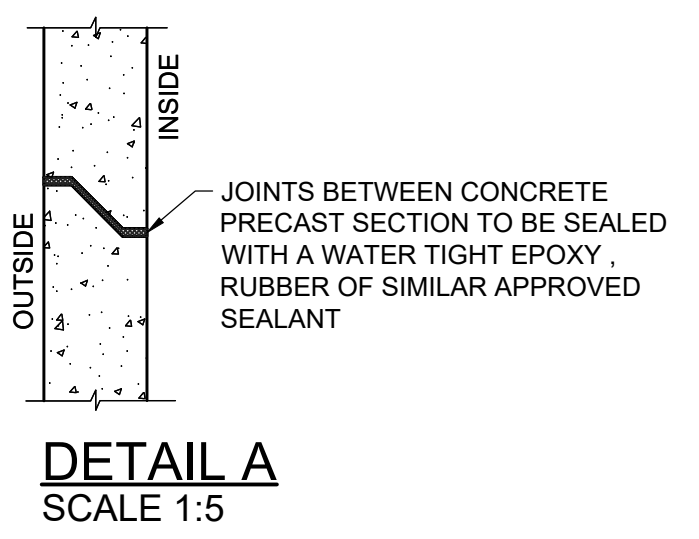

DETAIL A  
SCALE 1:5

**CONCRETE:**

ALL CONCRETE WORK SHALL COMPLY WITH THE REQUIREMENTS OF SANS 1200 G.

STRIPPING TIMES OF FORMWORK AND PROPPING SHALL BE IN ACCORDANCE WITH SANS 1200G.

PROVIDE A 25x25mm CHAMFER TO ALL EXPOSED CORNERS.

ALL EXPOSED CONCRETE WORK TO BE OFF - SHUTTER FINISH.

CEMENT EXTENDERS (eg. FLY ASH) TO BE USED ONLY IF APPROVED BY THE ENGINEER.

ALL EXPOSED SLAB EDGES TO HAVE 40mm COVER.

ALL INSIDE LEVELS REFER TO CONCRETE AND NOT TO FINISHED FLOOR EXCEPT WHERE OTHERWISE INDICATED.

THE CONTRACTOR SHALL PROVIDE ALL POURING PROCEDURES, CONSTRUCTION METHODS AND POSITIONS OF CONSTRUCTION JOINTS PRIOR TO COMMENCEMENT OF PROJECT.

THE GRADES OF CONCRETE SHALL BE AS FOLLOWS:  
ALL STRUCTURAL CONCRETE CLASS 30/19  
SURFACE BEDS CLASS 30/19  
BLINDING LAYERS CLASS 10/19  
MASS CONCRETE CLASS 10/19  
PROFILING CONCRETE CLASS 30/19

CONCRETE SHALL BE CURED IN ACCORDANCE WITH SANS 1200 G.

TEMPLATES SHALL BE USED TO SET H.D.BOLTS IF POCKETS ARE NOT PROVIDED.

PANELS BETWEEN CONSTRUCTION JOINTS TO BE CAST CONSECUTIVELY

BEFORE CONCRETING TAKES PLACE ALL FOUNDATIONS ARE TO BE INSPECTED ON SITE BY THE GEOTECHNICAL ENGINEER.

THE FOUNDATION LEVELS INDICATED ARE APPROXIMATE ONLY. FINAL FOUNDING LEVELS ARE TO BE DETERMINED ON SITE BY THE GEOTECHNICAL ENGINEER.

THE DIFFERENCE BETWEEN FINAL FOUNDING LEVELS AND BOTTOM OF FOUNDATIONS SHOWN TO BE MADE UP WITH 10 MPa MASS CONCRETE.

UNLESS NOTED ALL FOUNDATIONS TO HAVE A MINIMUM OF 50mm THICK 10MPa CONCRETE BLINDING LAYER.

DURING CONSTRUCTION ALL EXCAVATIONS SHALL BE KEPT FREE OF WATER.

ALL INTERNAL AND EXPOSED CONCRETE SHALL BE SHUTTERED. IF EXTERNAL CONCRETE IS NOT SHUTTERED, AN ADDITIONAL 25mm OF CONCRETE SHALL BE ADDED TO CREATE COVER OF 75mm.

THE BOTTOM OF ALL FOUNDATIONS ARE TO BE LEVEL. IF REQUIRED, STEPS MAY BE FORMED IN ACCORDANCE WITH SANS 10400, WITH THE APPROVAL OF THE ENGINEER.

TOP OF THE EXCAVATIONS IN CUT SHALL BE RIPPED & SCARIFIED FOR 150mm AND SHALL BE COMPACTED TO 95% MOD AASHTO AT OPTIMUM MOISTURE CONTENT.

ALL LEVELS FOR FOUNDATIONS SHALL BE CHECKED FOR ITS CORRECTNESS ON SITE.

**GENERAL NOTES:**

- 1) SPACER SLABS FOR HEAVY DUTY TYPE 2A & I MANHOLE COVERS AND FRAMES TO BE 900 x 900 x 75mm WITH 560Ø OPENING.
- 2) SPACER SLABS FOR MEDIUM DUTY TYPE 4 MANHOLE COVERS AND FRAMES TO BE 800 Ø x 75mm THICK WITH 560Ø OPENING.
- 3) ADAPTOR SLABS FOR HEAVY DUTY TYPE 2A & I MANHOLE COVERS AND FRAMES TO BE 900 x 900 x 125mm WITH 560Ø OPENING.
- 4) ADAPTOR SLABS FOR MEDIUM DUTY TYPE 4 MANHOLE COVERS AND FRAMES TO BE 860Ø WITH 560Ø OPENING.
- 5) OMIT ADAPTOR SLAB ON SHALLOW MANHOLES WHERE SHAFT SECTIONS ARE NOT REQUIRED.

**BRINK WORK NOTES:**

- 1) ALL PIPE CONNECTIONS TO MANHOLES TO HAVE FLEXIBLE JOINT AS PER DETAIL A.
- 2) BRICKWORK TO BE 220mm IN WIDTH (DOUBLE FACEBRICK WALLS).
- 3) ALL BRICKWORK TO BE PLASTERED INTERNALLY AND EXTERNALLY WITH 13mm 1:3 CEMENT MORTAR.
- 4) STEP IRONS TO BE PLACED AT 250mm CENTRES, STAGGERED LEFT AND RIGHT.

STRUCTURE LIST-NORTHERN OUTFALL SEWER				
MH. NAME	Y	X	INVERT LEVEL	DEPTH TO SUMP
MH25	-89 742.963	3 349 344.969	738.050	5.755
MH26	-89 750.601	3 349 334.998	738.892	6.710
MH27	-89 730.634	3 349 309.868	738.337	6.366
MH28	-89 724.256	3 349 253.676	737.000	5.362
MH29	-89 712.474	3 349 192.083	734.557	3.513
MH30	-89 677.086	3 349 122.483	732.000	2.380
MH31	-89 667.171	3 349 104.773	730.865	3.104
MH32	-89 615.319	3 349 043.321	728.706	2.018
MH33	-89 557.596	3 348 992.255	727.650	1.397
MH34	-89 555.277	3 348 935.259	727.531	1.748

PIPE LIST-NORTHERN OUTFALL SEWER				
PIPE NAME	START LEVEL	END LEVEL	Dis. (m)	Diam. (mm)
P25	732.295	732.232	11.312	355 mm Class 51
P26	732.182	732.021	30.911	355 mm Class 51
P27	731.971	731.688	55.394	355 mm Class 51
P28	731.638	731.325	61.364	355 mm Class 51
P29	731.043	730.653	76.832	355 mm Class 51
P30	729.620	729.518	19.049	355 mm Class 51
P31	727.761	727.359	79.158	355 mm Class 51
P32	726.688	726.303	75.823	355 mm Class 51

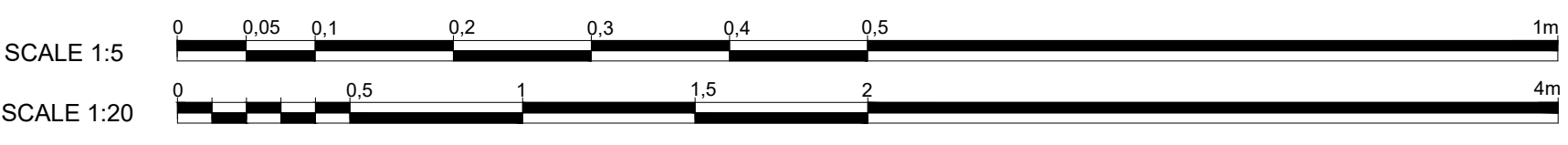
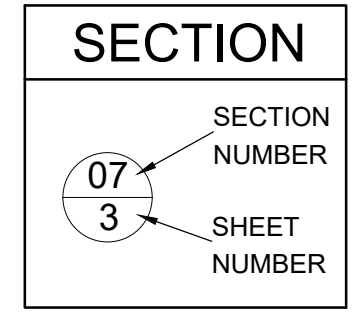

**FOR TENDER PURPOSES ONLY**

DESIGNED	N. NDLOVU
DRAWN	N. STUURMAN
CHECKED	B. SEAKE
ISSUED FOR TENDER	14/07/2021
NATURE OF REVISION	DATE

**ZIMILE**  
Consulting Engineers

INTERNATIONAL BUSINESS GATEWAY OFFICE PARK  
CNR PIONEER AVENUE AND ELIZABETH MIDRIDGE PARK  
TEL: (011) 466-8576  
FAX: (011) 466-8813  
E-MAIL: info@zimile.co.za

COPYRIGHT RESERVED ©

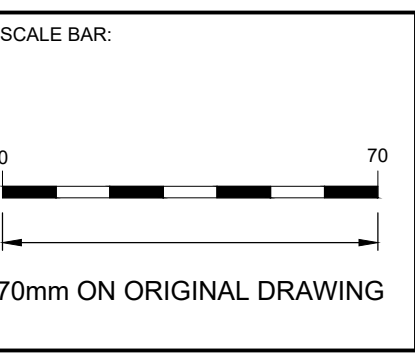

APPROVED:  
B. SEAKE  
FOR ZIMILE CONSULTING ENGINEERS

DESIGNATION: TECHNICAL MANAGER

DATE: \_\_\_\_\_ SIGNATURE: \_\_\_\_\_

PROJECT:  
UMZIMKHULU BULK SEWER

TITLE:  
355mmØ PIPE TYPE 1 MANHOLE DETAILS

PROJECT PHASE			
PRELIMINARY	TENDER	CONSTRUCTION	AS-BUILT
DATE:	JULY 2020		SCALE: AS SHOWN
DRAWING No.	J000096	WT	DE 202
CAD FILENAME	Mantle Details.dwg		SIZE: A1



STRUCTURE LIST-NORTHERN OUTFALL SEWER					
MH. NAME	Y	X	INVERT LEVEL	DEPTH TO SUMP	
MH25	-89 742.963	3 349 344.969	738.050	5.755	
MH26	-89 750.601	3 349 334.998	738.892	6.710	
MH27	-89 730.534	3 349 309.868	738.337	6.366	
MH28	-89 724.256	3 349 253.576	737.000	5.362	
MH29	-89 712.474	3 349 192.083	734.557	3.513	
MH30	-89 677.086	3 349 122.483	732.000	2.380	
MH31	-89 667.171	3 349 104.773	730.865	3.104	
MH32	-89 615.319	3 349 043.321	728.706	2.018	
MH33	-89 557.596	3 348 992.255	727.650	1.397	
MH34	-89 555.277	3 348 935.259	727.531	1.748	

PIPE LIST-NORTHERN OUTFALL SEWER					
NAME	START LEVEL	END LEVEL	Dis. (m)	Diam. (mm)	
P25	732.295	732.232	11.312	355 mm Class 51	
P26	732.182	732.021	30.911	355 mm Class 51	
P27	731.971	731.688	55.394	355 mm Class 51	
P28	731.638	731.325	61.364	355 mm Class 51	
P29	731.043	730.653	76.832	355 mm Class 51	
P30	729.620	729.518	19.049	355 mm Class 51	
P31	727.761	727.359	79.158	355 mm Class 51	
P32	726.688	726.303	75.823	355 mm Class 51	

**CONCRETE:**

ALL CONCRETE WORK SHALL COMPLY WITH THE REQUIREMENTS OF SANS 1200 G.  
 STRIPPING TIMES OF FORMWORK AND PROPPING SHALL BE IN ACCORDANCE WITH SANS 1200G.  
 PROVIDE A 25x25mm CHAMFER TO ALL EXPOSED CORNERS.  
 ALL EXPOSED CONCRETE WORK TO BE OFF - SHUTTER FINISH  
 CEMENT EXTENDERS (eg. FLY ASH) TO BE USED ONLY IF APPROVED BY THE ENGINEER.  
 ALL EXPOSED SLAB EDGES TO HAVE 40mm COVER.  
 ALL INSIDE LEVELS REFER TO CONCRETE AND NOT TO FINISHED FLOOR EXCEPT WHERE OTHERWISE INDICATED.

THE CONTRACTOR SHALL PROVIDE ALL POURING PROCEDURES, CONSTRUCTION METHODS AND POSITIONS OF CONSTRUCTION JOINTS PRIOR TO COMMENCEMENT OF PROJECT.  
 THE GRADES OF CONCRETE SHALL BE AS FOLLOWS:  
 ALL STRUCTURAL CONCRETE CLASS 30/19  
 SURFACE BEDS CLASS 30/19  
 BLINDING LAYERS CLASS 10/19  
 MASS CONCRETE CLASS 10/19  
 PROFILING CONCRETE CLASS 30/19  
 CONCRETE SHALL BE CURED IN ACCORDANCE WITH SANS 1200 G.  
 TEMPLATES SHALL BE USED TO SET H.D.BOLTS IF POCKETS ARE NOT PROVIDED.  
 PANELS BETWEEN CONSTRUCTION JOINTS TO BE CAST CONSECUTIVELY  
 BEFORE CONCRETING TAKES PLACE ALL FOUNDATIONS ARE TO BE INSPECTED ON SITE BY THE GEOTECHNICAL ENGINEER.  
 THE FOUNDATION LEVELS INDICATED ARE APPROXIMATE ONLY. FINAL FOUNDING LEVELS ARE TO BE DETERMINED ON SITE BY THE GEOTECHNICAL ENGINEER.

THE DIFFERENCE BETWEEN FINAL FOUNDING LEVELS AND BOTTOM OF FOUNDATIONS SHOWN TO BE MADE UP WITH 10 MPa MASS CONCRETE UNLESS NOTED ALL FOUNDATIONS TO HAVE A MINIMUM OF 50mm THICK 10MPa CONCRETE BLINDING LAYER.  
 DURING CONSTRUCTION ALL EXCAVATIONS SHALL BE KEPT FREE OF WATER.  
 ALL INTERNAL AND EXPOSED CONCRETE SHALL BE SHUTTERED. IF EXTERNAL CONCRETE IS NOT SHUTTERED, AN ADDITIONAL 25mm OF CONCRETE SHALL BE ADDED TO CREATE COVER OF 75mm.  
 THE BOTTOM OF ALL FOUNDATIONS ARE TO BE LEVEL. IF REQUIRED, STEPS MAY BE FORMED IN ACCORDANCE WITH SANS 10400, WITH THE APPROVAL OF THE ENGINEER.  
 TOP OF THE EXCAVATIONS IN CUT SHALL BE RIPPED & SCARIFIED FOR 150mm AND SHALL BE COMPACTED TO 95% MOD AASHTO AT OPTIMUM MOISTURE CONTENT.  
 ALL LEVELS FOR FOUNDATIONS SHALL BE CHECKED FOR ITS CORRECTNESS ON SITE.

**GENERAL NOTES:**

- 1) SPACER SLABS FOR HEAVY DUTY TYPE 2A & I MANHOLE COVERS AND FRAMES TO BE 900 x 900 x 75mm WITH 560Ø OPENING.
- 2) SPACER SLABS FOR MEDIUM DUTY TYPE 4 MANHOLE COVERS AND FRAMES TO BE 800 Ø x 75mm THICK WITH 560Ø OPENING.
- 3) ADAPTOR SLABS FOR HEAVY DUTY TYPE 2A & I MANHOLE COVERS AND FRAMES TO BE 900 x 900 x 125mm WITH 560Ø OPENING.
- 4) ADAPTOR SLABS FOR MEDIUM DUTY TYPE 4 MANHOLE COVERS AND FRAMES TO BE 860Ø WITH 560Ø OPENING.
- 5) OMIT ADAPTOR SLAB ON SHALLOW MANHOLES WHERE SHAFT SECTIONS ARE NOT REQUIRED.

**BRINK WORK NOTES:**

- 1) ALL PIPE CONNECTIONS TO MANHOLES TO HAVE FLEXIBLE JOINT AS PER DETAIL A.
- 2) BRICKWORK TO BE 220mm IN WIDTH (DOUBLE FACEBRICK WALLS).
- 3) ALL BRICKWORK TO BE PLASTERED INTERNALLY AND EXTERNALLY WITH 13mm 1:3 CEMENT MORTAR.
- 4) STEP IRONS TO BE PLACED AT 250mm CENTRES, STAGGERED LEFT AND RIGHT.

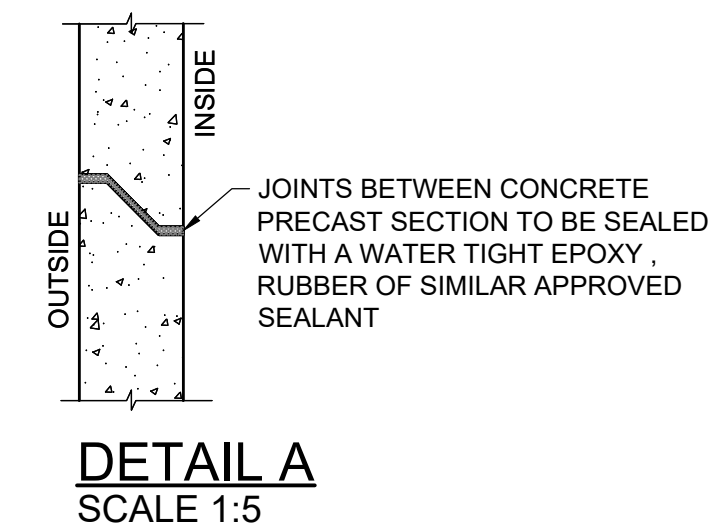
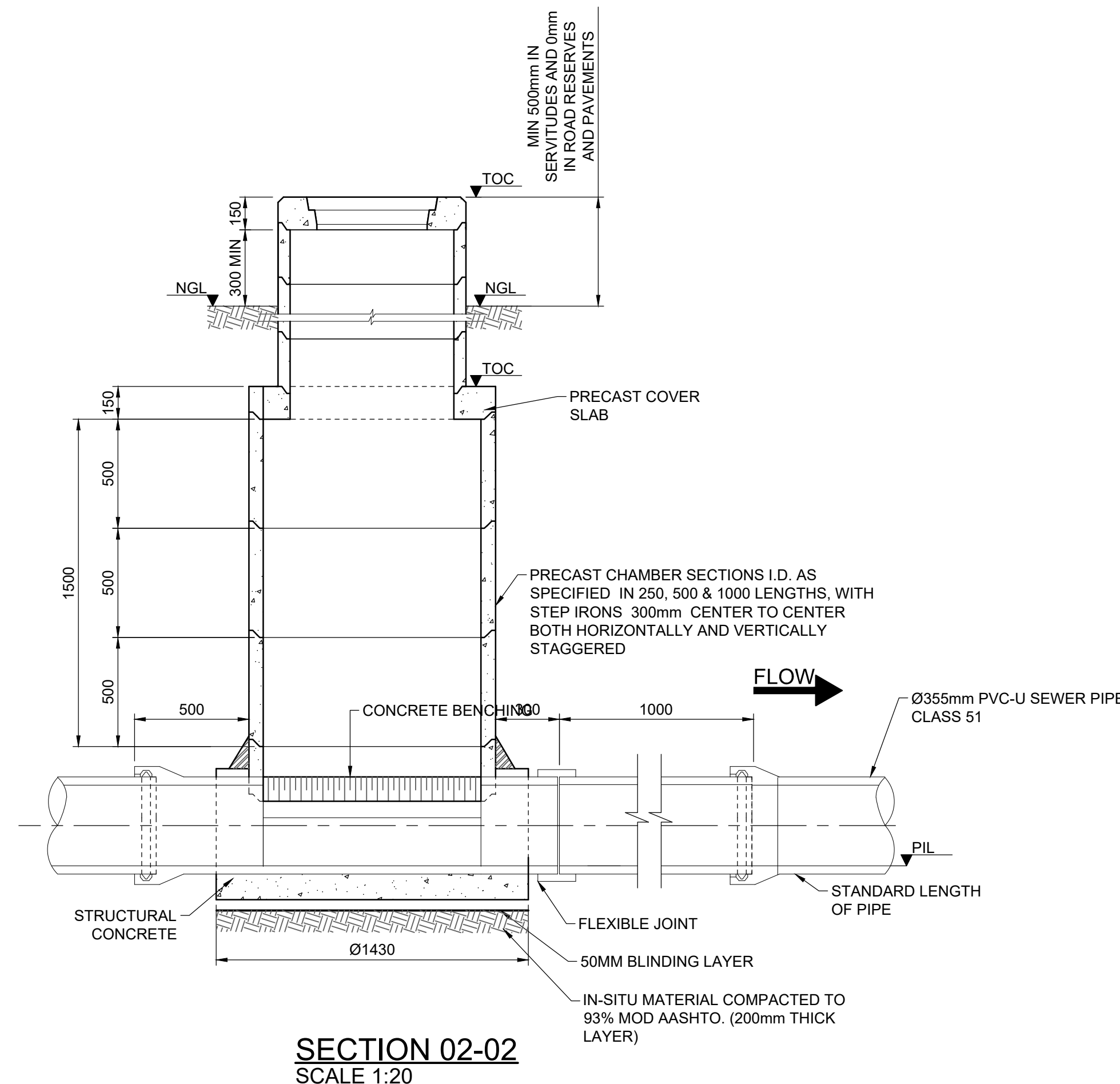
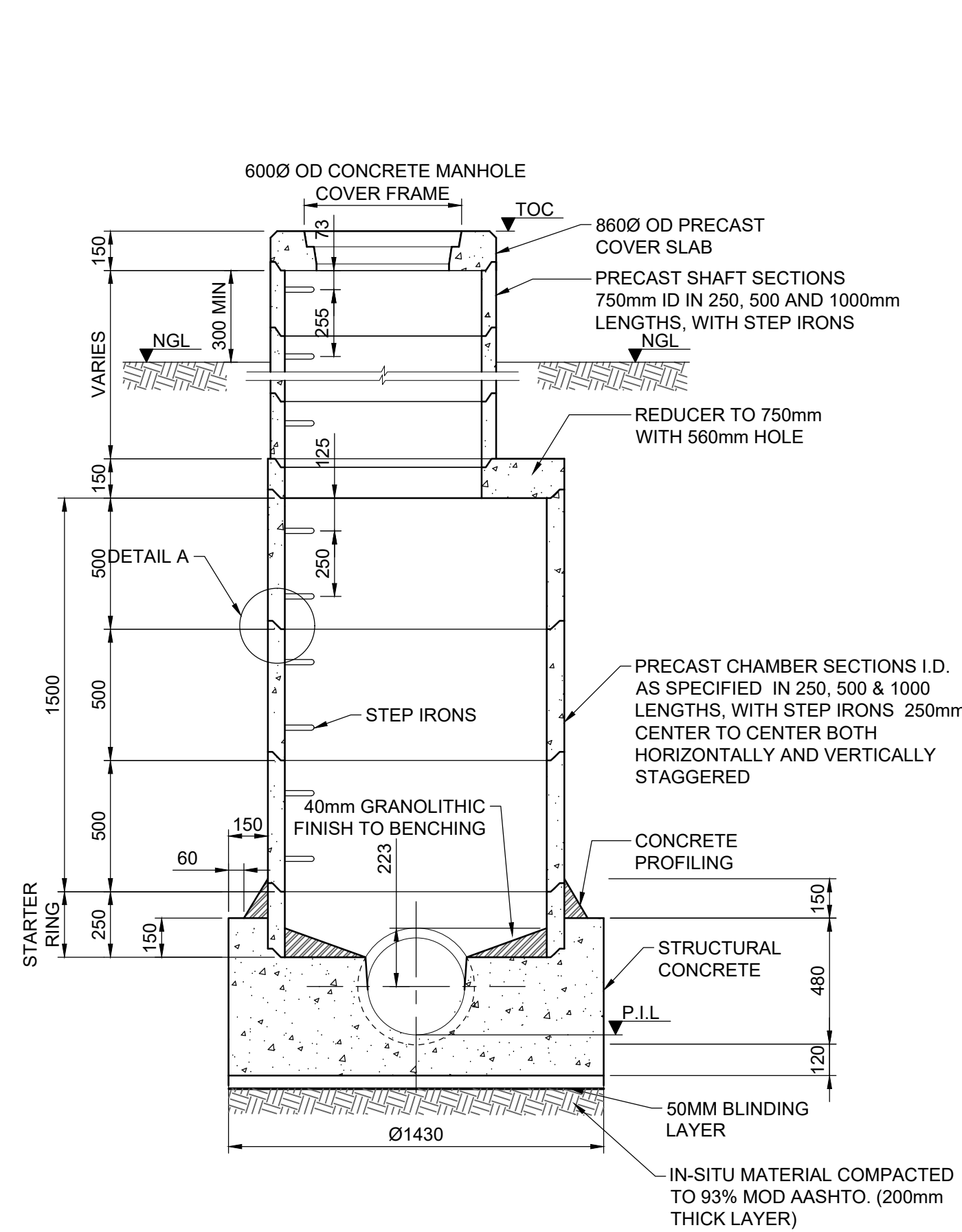
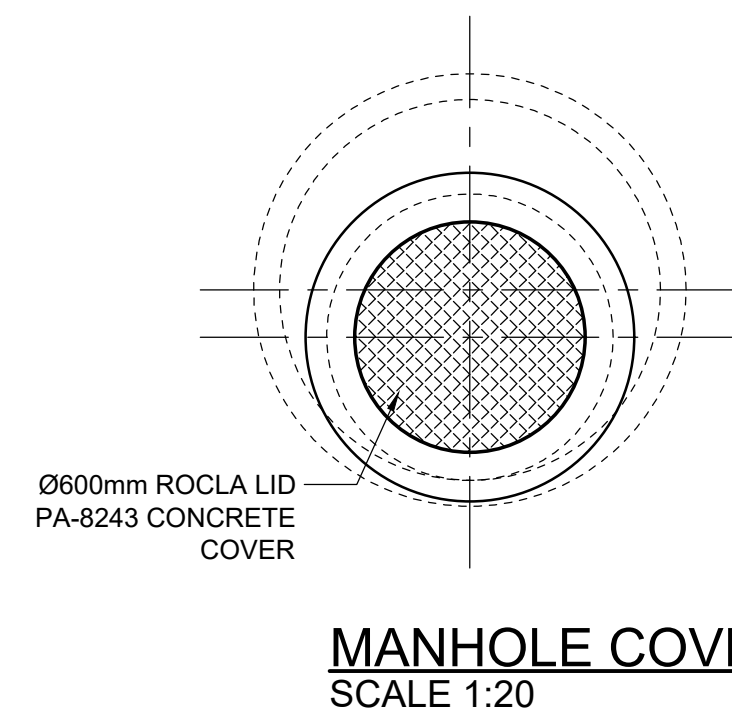
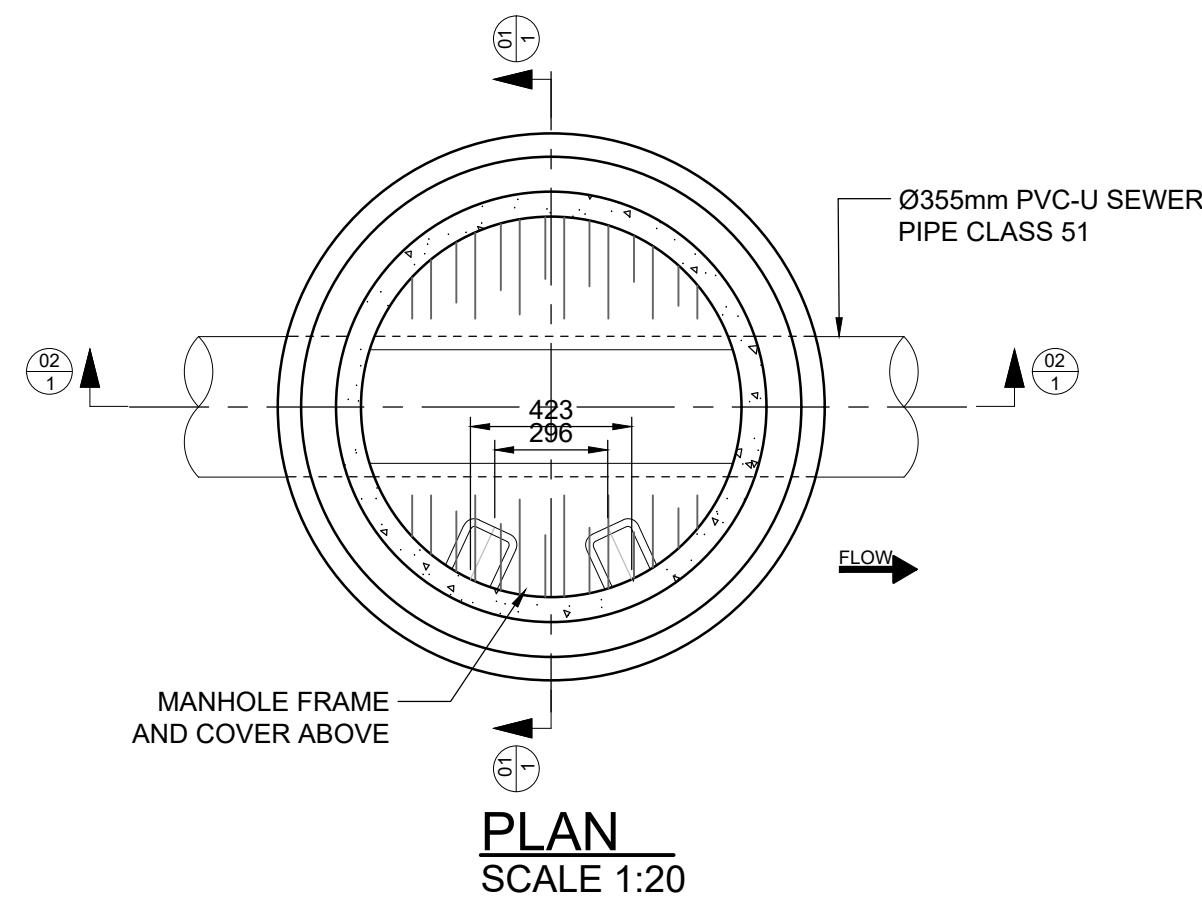

SECTION	
SECTION NUMBER	07
SHEET NUMBER	3

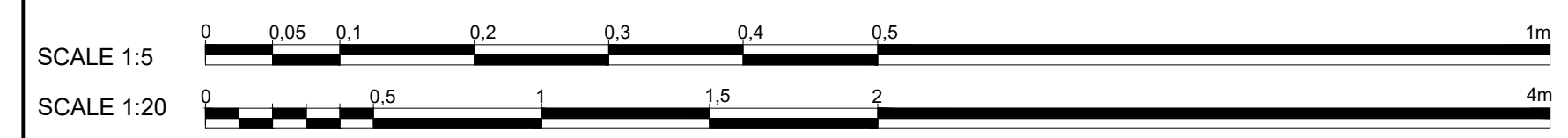

DESIGNED	DRAWN	CHECKED	DATE
N. NDLOVU	N. STUURMAN	B. SEAKE	14/07/2021

**ZIMILE Consulting Engineers**  
 INTERNATIONAL BUSINESS GATEWAY OFFICE PARK  
 CNR PIONEER AVENUE AND ELIZABETH MIDRIDGE PARK  
 TEL: (011) 466-8576 FAX: (011) 466-8813  
 E-MAIL: info@zimile.co.za  
 COPYRIGHT RESERVED ©

SCALE BAR: 70mm ON ORIGINAL DRAWING

CLIENT:

APPROVED: **B. SEAKE**  
 FOR ZIMILE CONSULTING ENGINEERS  
 DESIGNATION: TECHNICAL MANAGER  
 DATE: \_\_\_\_\_ SIGNATURE: \_\_\_\_\_

PROJECT: **UMZIMKHULU BULK SEWER**

TITLE: **355mmØ PIPE TYPE 2 MANHOLE DETAILS**

PROJECT PHASE			
PRELIMINARY	TENDER	CONSTRUCTION	AS-BUILT
DATE:	JULY 2020	SCALE:	AS SHOWN
DRAWING No.	J000096	WT	DE 203
CAD FILENAME	Y:\Current Projects\WATER DEPARTMENT\J000096 - Umzimkhulu Bulk Sewer Procurement Stage1 - Tender Drawings\03 - Station 01 Working Drawings\J000096-WT-DE-203_RevA_355mm Dia Pipe Type 2 Sewer Manhole Details.dwg		REVISION
			A
			A1

**FOR TENDER PURPOSES ONLY**



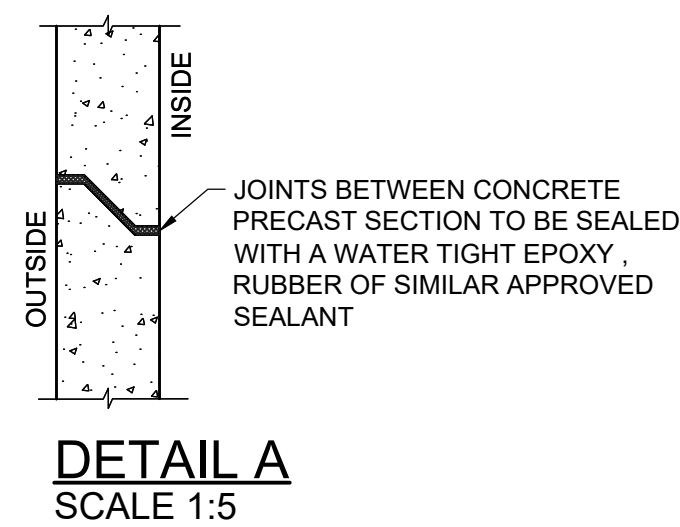
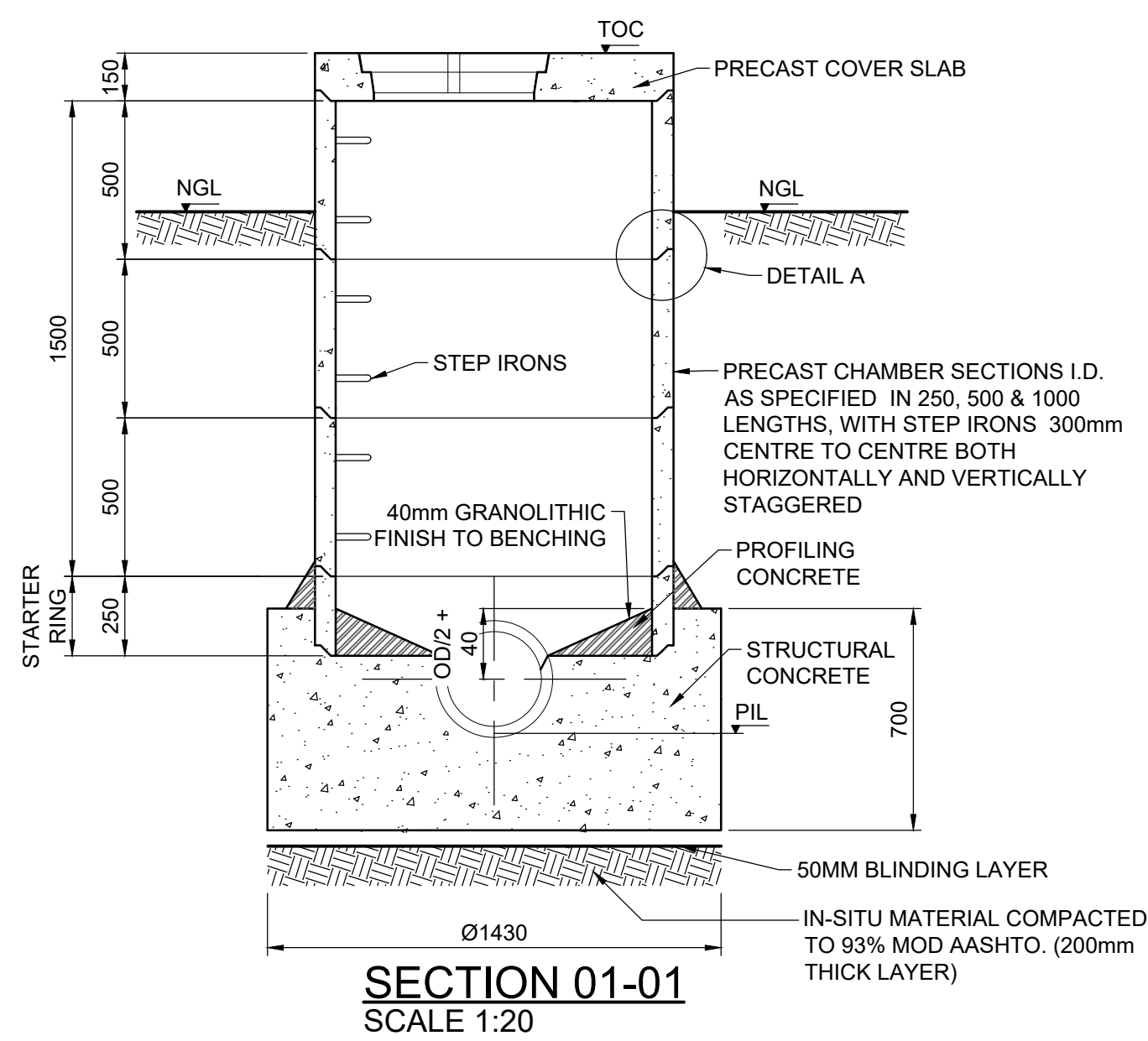
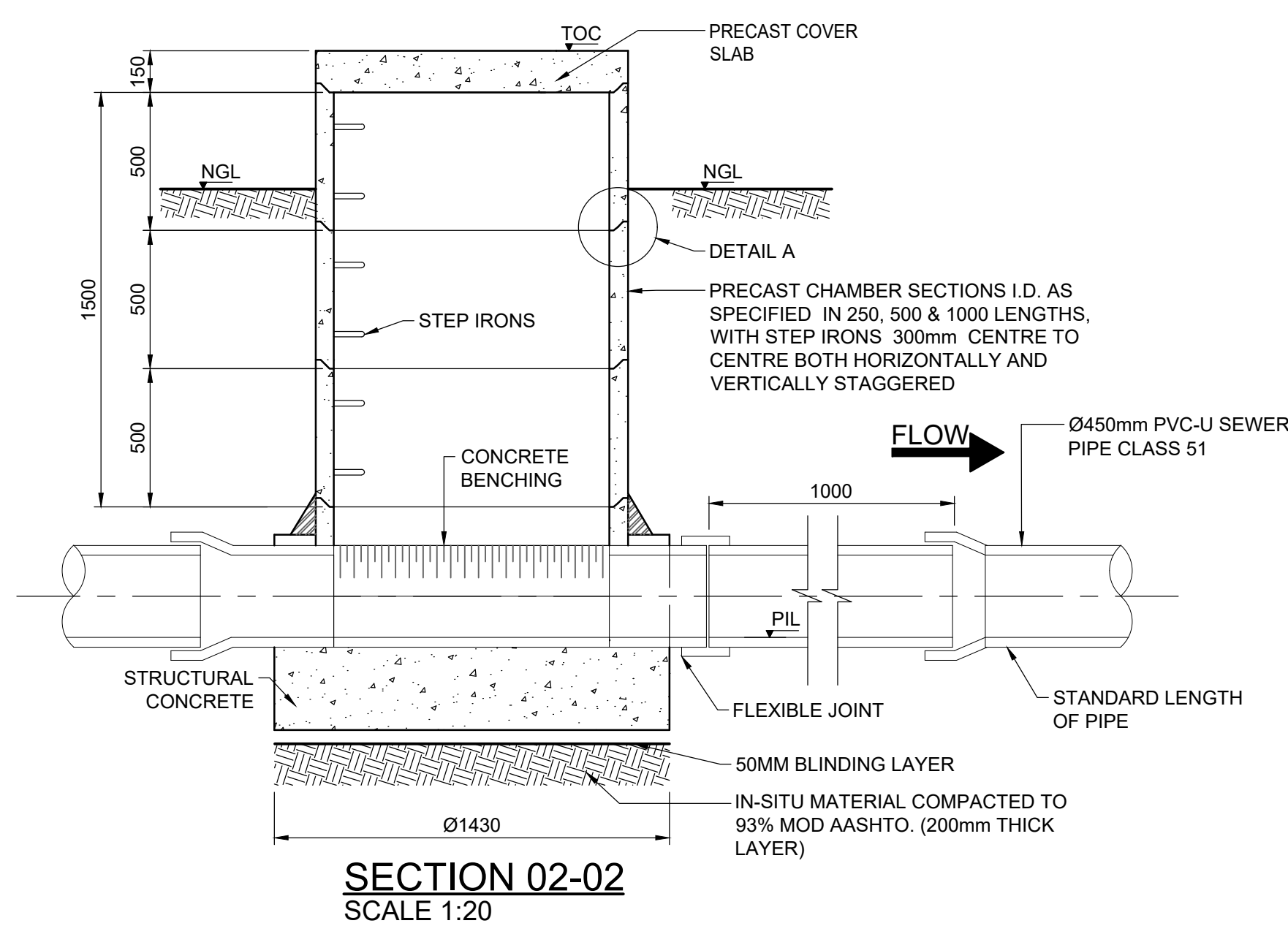
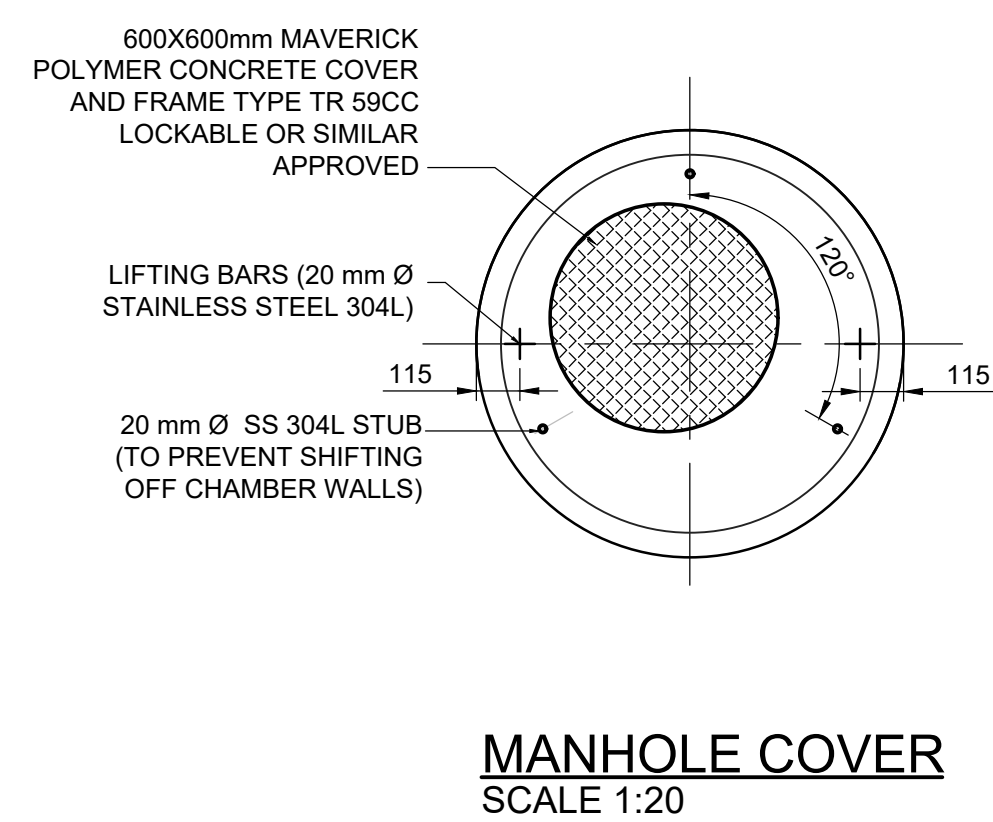
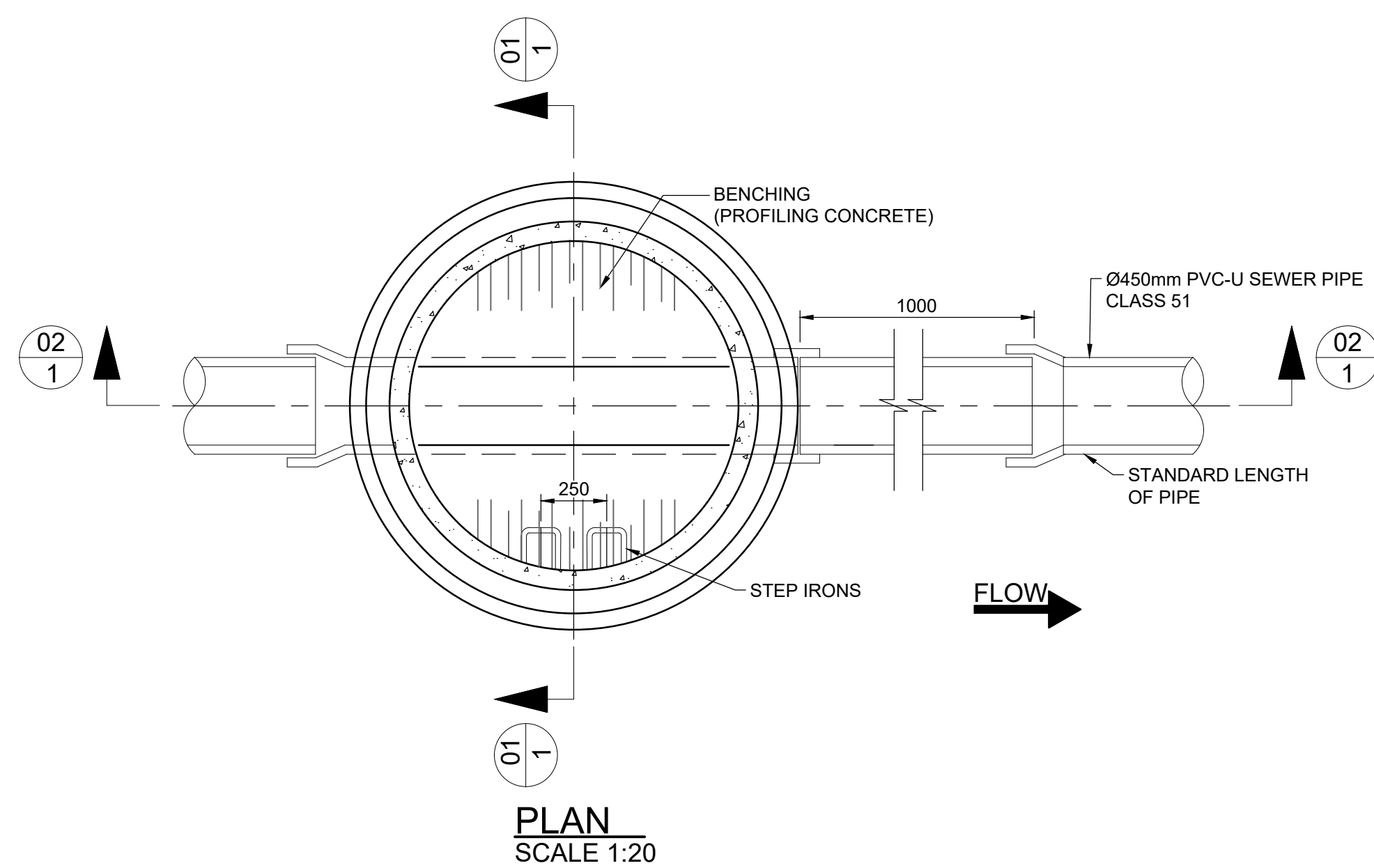

**CONCRETE:**

ALL CONCRETE WORK SHALL COMPLY WITH THE REQUIREMENTS OF SANS 1200 G.

STRIPPING TIMES OF FORMWORK AND PROPPING SHALL BE IN ACCORDANCE WITH SANS 1200G.

PROVIDE A 25x25mm CHAMFER TO ALL EXPOSED CORNERS.

ALL EXPOSED CONCRETE WORK TO BE OFF-SHUTTER FINISH.

CEMENT EXTENDERS (eg. FLY ASH) TO BE USED ONLY IF APPROVED BY THE ENGINEER.

ALL EXPOSED SLAB EDGES TO HAVE 40mm COVER.

ALL INSIDE LEVELS REFER TO CONCRETE AND NOT TO FINISHED FLOOR EXCEPT WHERE OTHERWISE INDICATED.

THE CONTRACTOR SHALL PROVIDE ALL POURING PROCEDURES, CONSTRUCTION METHODS AND POSITIONS OF CONSTRUCTION JOINTS PRIOR TO COMMENCEMENT OF PROJECT.

THE GRADES OF CONCRETE SHALL BE AS FOLLOWS:  
 ALL STRUCTURAL CONCRETE CLASS 30/19  
 SURFACE BEDS CLASS 30/19  
 BLINDING LAYERS CLASS 10/19  
 MASS CONCRETE CLASS 10/19  
 PROFILING CONCRETE CLASS 30/19

CONCRETE SHALL BE CURED IN ACCORDANCE WITH SANS 1200 G.

TEMPLATES SHALL BE USED TO SET H.D. BOLTS IF POCKETS ARE NOT PROVIDED.

PANELS BETWEEN CONSTRUCTION JOINTS TO BE CAST CONSECUTIVELY

BEFORE CONCRETING TAKES PLACE ALL FOUNDATIONS ARE TO BE INSPECTED ON SITE BY THE GEOTECHNICAL ENGINEER.

THE DIFFERENCE BETWEEN FINAL FOUNDING LEVELS AND BOTTOM OF FOUNDATIONS SHOWN TO BE MADE UP WITH 10 MPa MASS CONCRETE.

UNLESS NOTED ALL FOUNDATIONS TO HAVE A MINIMUM OF 50mm THICK 10MPa CONCRETE BLINDING LAYER.

DURING CONSTRUCTION ALL EXCAVATIONS SHALL BE KEPT FREE OF WATER.

ALL INTERNAL AND EXPOSED CONCRETE SHALL BE SHUTTERED. IF EXTERNAL CONCRETE IS NOT SHUTTERED, AN ADDITIONAL 25mm OF CONCRETE SHALL BE ADDED TO CREATE COVER OF 75mm.

THE BOTTOM OF ALL FOUNDATIONS ARE TO BE LEVEL. IF REQUIRED, STEPS MAY BE FORMED IN ACCORDANCE WITH SANS 10400, WITH THE APPROVAL OF THE ENGINEER.

TOP OF THE EXCAVATIONS IN CUT SHALL BE RIPPED & SCARIFIED FOR 150mm AND SHALL BE COMPACTED TO 95% MOD AASHTO AT OPTIMUM MOISTURE CONTENT.

ALL LEVELS FOR FOUNDATIONS SHALL BE CHECKED FOR ITS CORRECTNESS ON SITE.

**GENERAL NOTES:**

- 1) SPACER SLABS FOR HEAVY DUTY TYPE 2A & I MANHOLE COVERS AND FRAMES TO BE 900 x 900 x 75mm WITH 560Ø OPENING.
- 2) SPACER SLABS FOR MEDIUM DUTY TYPE 4 MANHOLE COVERS AND FRAMES TO BE 800 Ø x 75mm THICK WITH 560Ø OPENING.
- 3) ADAPTOR SLABS FOR HEAVY DUTY TYPE 2A & I MANHOLE COVERS AND FRAMES TO BE 900 x 900 x 125mm WITH 560Ø OPENING.
- 4) ADAPTOR SLABS FOR MEDIUM DUTY TYPE 4 MANHOLE COVERS AND FRAMES TO BE 860Ø WITH 560Ø OPENING.
- 5) OMIT ADAPTOR SLAB ON SHALLOW MANHOLES WHERE SHAFT SECTIONS ARE NOT REQUIRED.

**BRICK WORK NOTES:**

- 1) ALL PIPE CONNECTIONS TO MANHOLES TO HAVE FLEXIBLE JOINT AS PER DETAIL A.
- 2) BRICKWORK TO BE 220mm IN WIDTH (DOUBLE FACEBRICK WALLS).
- 3) ALL BRICKWORK TO BE PLASTERED INTERNALLY AND EXTERNALLY WITH 13mm 1:3 CEMENT MORTAR.
- 4) STEP IRONS TO BE PLACED AT 250mm CENTRES, STAGGERED LEFT AND RIGHT.

STRUCTURE LIST-NORTHERN OUTFALL SEWER				
MH. NAME	Y	X	INVERT LEVEL	DEPTH TO SUMP
MH34	-89 555.277	3 348 935.259	727.531	1.748
MH45	-89 572.921	3 348 882.213	728.000	2.547
MH46	-89 619.846	3 348 846.635	728.421	3.312
MH47	-89 696.590	3 348 863.981	728.078	3.413
MH48	-89 774.621	3 348 881.618	727.811	3.987
MH49	-89 860.996	3 348 901.141	727.505	3.783
MH50	-89 948.628	3 348 927.278	727.410	4.195
MH51	-90 025.290	3 348 950.144	727.100	4.726
MH52	-90 107.231	3 348 974.583	727.000	4.712
MH53	-90 192.101	3 349 016.127	726.743	4.978
MH54	-90 263.955	3 349 051.298	726.575	5.651
MH55	-90 335.808	3 349 086.470	726.484	6.010
MH56	-90 392.860	3 349 114.397	726.756	6.259
MH57	-90 438.434	3 349 147.759	726.529	6.364
MH58	-90 488.428	3 349 184.357	726.511	6.753

PIPE LIST-NORTHERN OUTFALL SEWER				
PIPE NAME	START LEVEL	END LEVEL	Dis. (m)	Diam. (mm)
P44	725.783	725.503	54.657	450 mm CLASS 51
P45	725.453	725.159	57.640	450 mm CLASS 51
P46	725.109	724.715	77.433	450 mm CLASS 51
P47	724.665	724.265	78.753	450 mm CLASS 51
P48	724.215	723.772	87.307	450 mm CLASS 51
P49	723.722	723.265	90.200	450 mm CLASS 51
P50	723.215	722.815	78.753	450 mm CLASS 51
P51	722.765	722.338	84.261	450 mm CLASS 51
P52	722.288	721.815	93.246	450 mm CLASS 51
P53	721.765	721.365	78.753	450 mm CLASS 51
P54	721.315	720.915	78.753	450 mm CLASS 51
P55	720.865	720.548	62.273	450 mm CLASS 51
P56	720.498	720.215	55.233	450 mm CLASS 51
P57	720.165	719.855	60.711	450 mm CLASS 51

**SECTION**

SECTION NUMBER: 07

SHEET NUMBER: 3

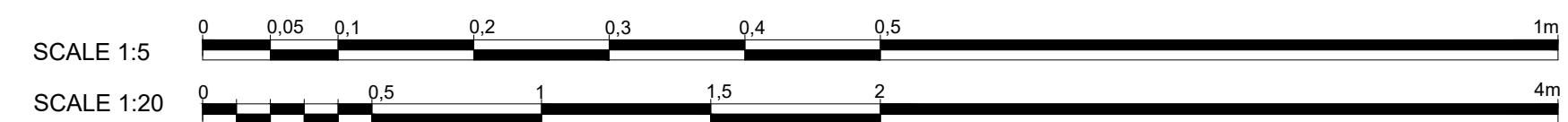

DESIGNED	N. NDLOVU
DRAWN	N. STUURMAN
CHECKED	B. SEAKE
ISSUED FOR TENDER	14/07/2021
NATURE OF REVISION	DATE

**ZIMILE** CONSULTING ENGINEERS

INTERNATIONAL BUSINESS GATEWAY OFFICE PARK  
 CNR PIONEER AVENUE AND ELIZABETH MIDRIDGE PARK  
 TEL: (011) 466-8576 FAX: (011) 466-8813  
 E-MAIL: info@zimile.co.za

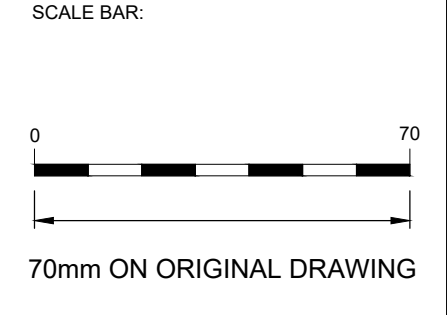

CLIENT:

APPROVED: B. SEAKE  
 FOR ZIMILE CONSULTING ENGINEERS  
 DESIGNATION: TECHNICAL MANAGER  
 DATE: \_\_\_\_\_ SIGNATURE: \_\_\_\_\_

PROJECT: UMZIMKHULU BULK SEWER

TITLE: 450mmØ PIPE TYPE 1 MANHOLE DETAILS

PROJECT PHASE			
PRELIMINARY	TENDER	CONSTRUCTION	AS-BUILT
DATE: JULY 2020	SCALE: AS SHOWN		
DRAWING No. J000096	WT	DE	204
CAD FILENAME	SHEET NO. 204		REVISION A
SIZE: A1			DATE: 14/07/2021

**FOR TENDER PURPOSES ONLY**



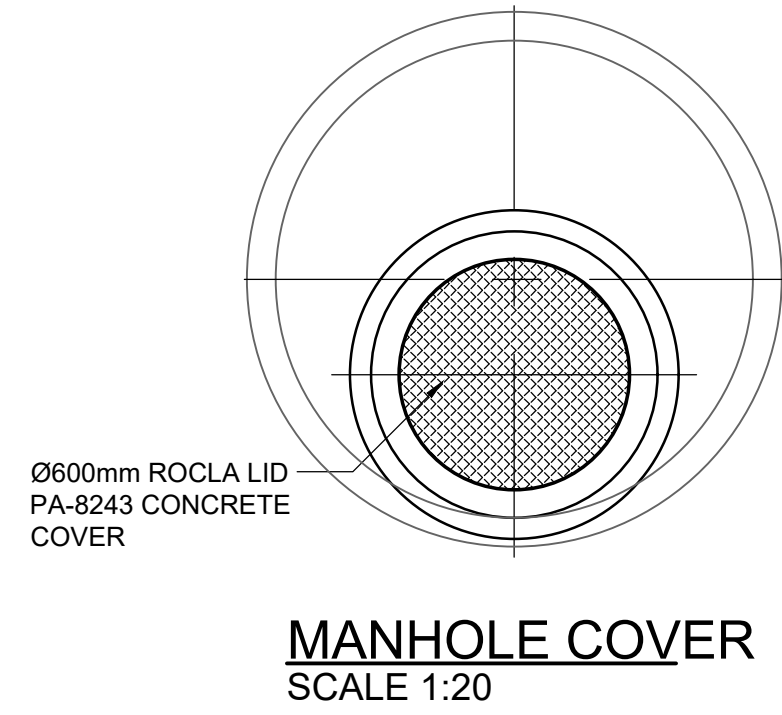
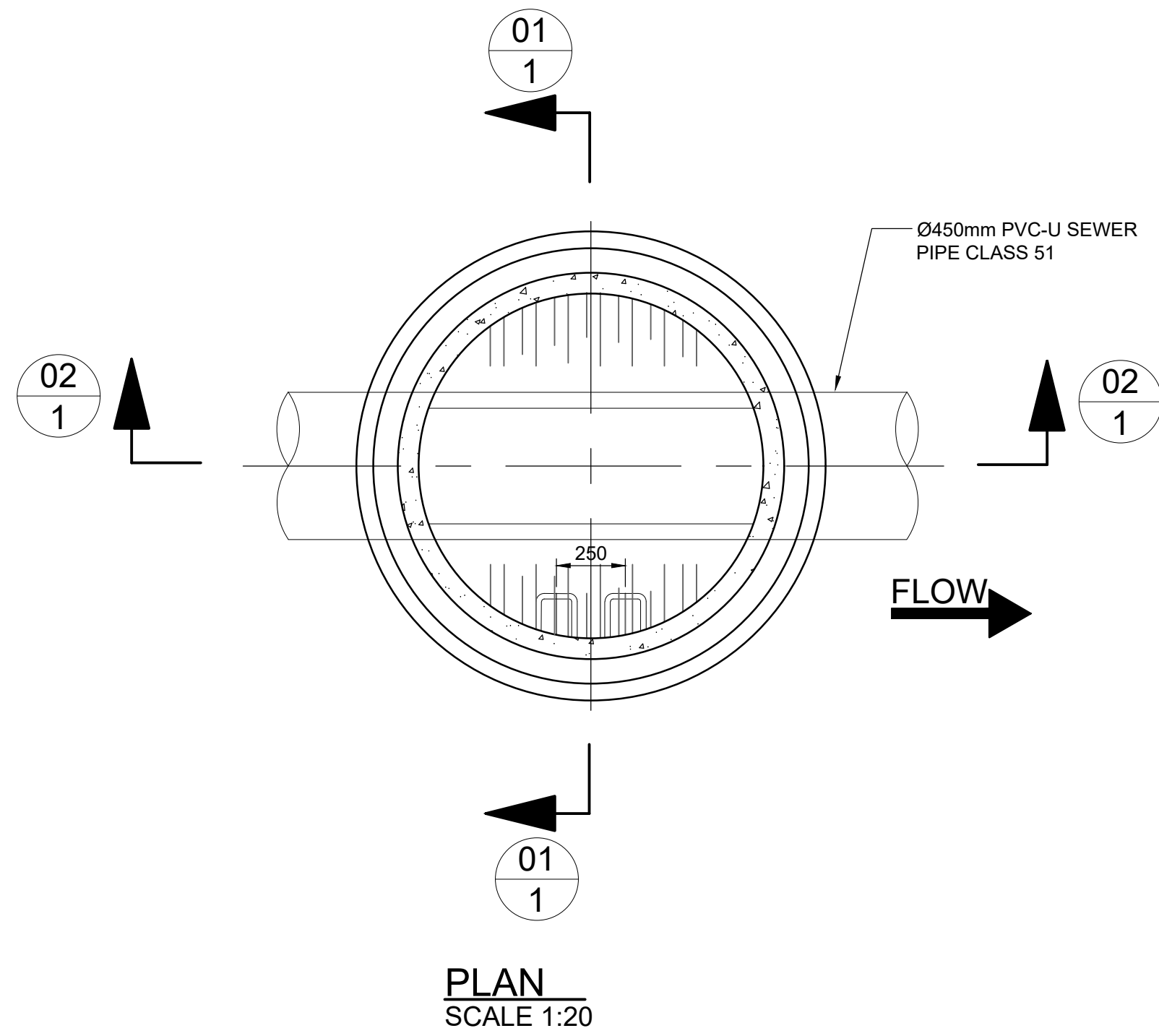

STRUCTURE LIST-NORTHERN OUTFALL SEWER				
MH. NAME	Y	X	INVERT LEVEL	DEPTH TO SUMP
MH34	-89 555.277	3 348 935.259	727.531	1.748
MH45	-89 572.921	3 348 882.213	728.000	2.547
MH46	-89 619.846	3 348 846.635	728.421	3.312
MH47	-89 696.590	3 348 863.981	728.078	3.413
MH48	-89 774.621	3 348 881.618	727.811	3.987
MH49	-89 860.996	3 348 901.141	727.505	3.783
MH50	-89 948.628	3 348 927.278	727.410	4.195
MH51	-90 025.290	3 348 950.144	727.100	4.726
MH52	-90 107.231	3 348 974.583	727.000	4.712
MH53	-90 192.101	3 349 016.127	726.743	4.978
MH54	-90 263.955	3 349 051.298	726.575	5.651
MH55	-90 335.808	3 349 086.470	726.484	6.010
MH56	-90 392.860	3 349 114.397	726.756	6.259
MH57	-90 438.434	3 349 147.759	726.529	6.364
MH58	-90 488.428	3 349 184.357	726.511	6.753

PIPE LIST-NORTHERN OUTFALL SEWER				
NAME	START LEVEL	END LEVEL	Dis. (m)	Diam. (mm)
P44	725.783	725.503	54.657	450 mm CLASS 51
P45	725.453	725.159	57.640	450 mm CLASS 51
P46	725.109	724.715	77.433	450 mm CLASS 51
P47	724.665	724.265	78.753	450 mm CLASS 51
P48	724.215	723.772	87.307	450 mm CLASS 51
P49	723.722	723.265	90.200	450 mm CLASS 51
P50	723.215	722.815	78.753	450 mm CLASS 51
P51	722.765	722.338	84.261	450 mm CLASS 51
P52	722.288	721.815	93.246	450 mm CLASS 51
P53	721.765	721.365	78.753	450 mm CLASS 51
P54	721.315	720.915	78.753	450 mm CLASS 51
P55	720.865	720.548	62.273	450 mm CLASS 51
P56	720.498	720.215	55.233	450 mm CLASS 51
P57	720.165	719.855	60.711	450 mm CLASS 51

**CONCRETE:**

ALL CONCRETE WORK SHALL COMPLY WITH THE REQUIREMENTS OF SANS 1200 G.

STRIPPING TIMES OF FORMWORK AND PROPPING SHALL BE IN ACCORDANCE WITH SANS 1200G.

PROVIDE A 25x25mm CHAMFER TO ALL EXPOSED CORNERS.

ALL EXPOSED CONCRETE WORK TO BE OFF - SHUTTER FINISH

CEMENT EXTENDERS (eg. FLY ASH) TO BE USED ONLY IF APPROVED BY THE ENGINEER.

ALL EXPOSED SLAB EDGES TO HAVE 40mm COVER.

ALL INSIDE LEVELS REFER TO CONCRETE AND NOT TO FINISHED FLOOR EXCEPT WHERE OTHERWISE INDICATED.

THE CONTRACTOR SHALL PROVIDE ALL POURING PROCEDURES, CONSTRUCTION METHODS AND POSITIONS OF CONSTRUCTION JOINTS PRIOR TO COMMENCEMENT OF PROJECT.

THE GRADES OF CONCRETE SHALL BE AS FOLLOWS:

- ALL STRUCTURAL CONCRETE CLASS 30/19
- SURFACE BEDS CLASS 30/19
- BLINDING LAYERS CLASS 10/19
- MASS CONCRETE CLASS 10/19
- PROFILING CONCRETE CLASS 30/19

CONCRETE SHALL BE CURED IN ACCORDANCE WITH SANS 1200 G.

TEMPLATES SHALL BE USED TO SET H.D.BOLTS IF POCKETS ARE NOT PROVIDED.

PANELS BETWEEN CONSTRUCTION JOINTS TO BE CAST CONSECUTIVELY

BEFORE CONCRETING TAKES PLACE ALL FOUNDATIONS ARE TO BE INSPECTED ON SITE BY THE GEOTECHNICAL ENGINEER.

THE FOUNDATION LEVELS INDICATED ARE APPROXIMATE ONLY. FINAL FOUNDING LEVELS ARE TO BE DETERMINED ON SITE BY THE GEOTECHNICAL ENGINEER.

THE DIFFERENCE BETWEEN FINAL FOUNDING LEVELS AND BOTTOM OF FOUNDATIONS SHOWN TO BE MADE UP WITH 10 MPa MASS CONCRETE

UNLESS NOTED ALL FOUNDATIONS TO HAVE A MINIMUM OF 50mm THICK 10MPa CONCRETE BLINDING LAYER.

DURING CONSTRUCTION ALL EXCAVATIONS SHALL BE KEPT FREE OF WATER.

ALL INTERNAL AND EXPOSED CONCRETE SHALL BE SHUTTERED. IF EXTERNAL CONCRETE IS NOT SHUTTERED, AN ADDITIONAL 25mm OF CONCRETE SHALL BE ADDED TO CREATE COVER OF 75mm.

THE BOTTOM OF ALL FOUNDATIONS ARE TO BE LEVEL. IF REQUIRED, STEPS MAY BE FORMED IN ACCORDANCE WITH SANS 10400, WITH THE APPROVAL OF THE ENGINEER.

TOP OF THE EXCAVATIONS IN CUT SHALL BE RIPPED & SCARIFIED FOR 150mm AND SHALL BE COMPACTED TO 95% MOD AASHTO AT OPTIMUM MOISTURE CONTENT.

ALL LEVELS FOR FOUNDATIONS SHALL BE CHECKED FOR ITS CORRECTNESS ON SITE.

**GENERAL NOTES:**

- 1) SPACER SLABS FOR HEAVY DUTY TYPE 2A & I MANHOLE COVERS AND FRAMES TO BE 900 x 900 x 75mm WITH 560Ø OPENING.
- 2) SPACER SLABS FOR MEDIUM DUTY TYPE 4 MANHOLE COVERS AND FRAMES TO BE 800 Ø x 75mm THICK WITH 560Ø OPENING.
- 3) ADAPTOR SLABS FOR HEAVY DUTY TYPE 2A & I MANHOLE COVERS AND FRAMES TO BE 900 x 900 x 125mm WITH 560Ø OPENING.
- 4) ADAPTOR SLABS FOR MEDIUM DUTY TYPE 4 MANHOLE COVERS AND FRAMES TO BE 860Ø WITH 560Ø OPENING.
- 5) OMIT ADAPTOR SLAB ON SHALLOW MANHOLES WHERE SHAFT SECTIONS ARE NOT REQUIRED.

**BRICK WORK NOTES:**

- 1) ALL PIPE CONNECTIONS TO MANHOLES TO HAVE FLEXIBLE JOINT AS PER DETAIL A.
- 2) BRICKWORK TO BE 220mm IN WIDTH (DOUBLE FACEBRICK WALLS).
- 3) ALL BRICKWORK TO BE PLASTERED INTERNALLY AND EXTERNALLY WITH 13mm 1:3 CEMENT MORTAR.
- 4) STEP IRONS TO BE PLACED AT 250mm CENTRES, STAGGERED LEFT AND RIGHT.

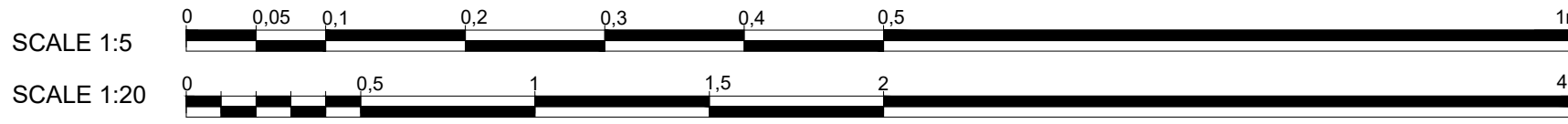
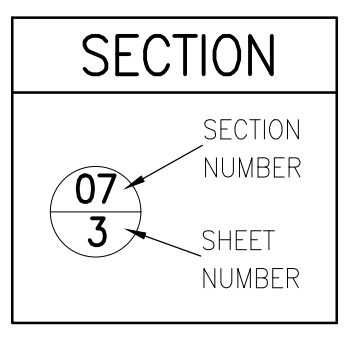
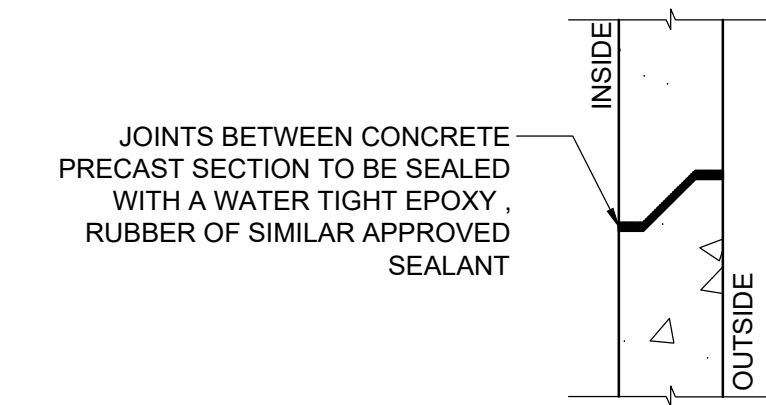
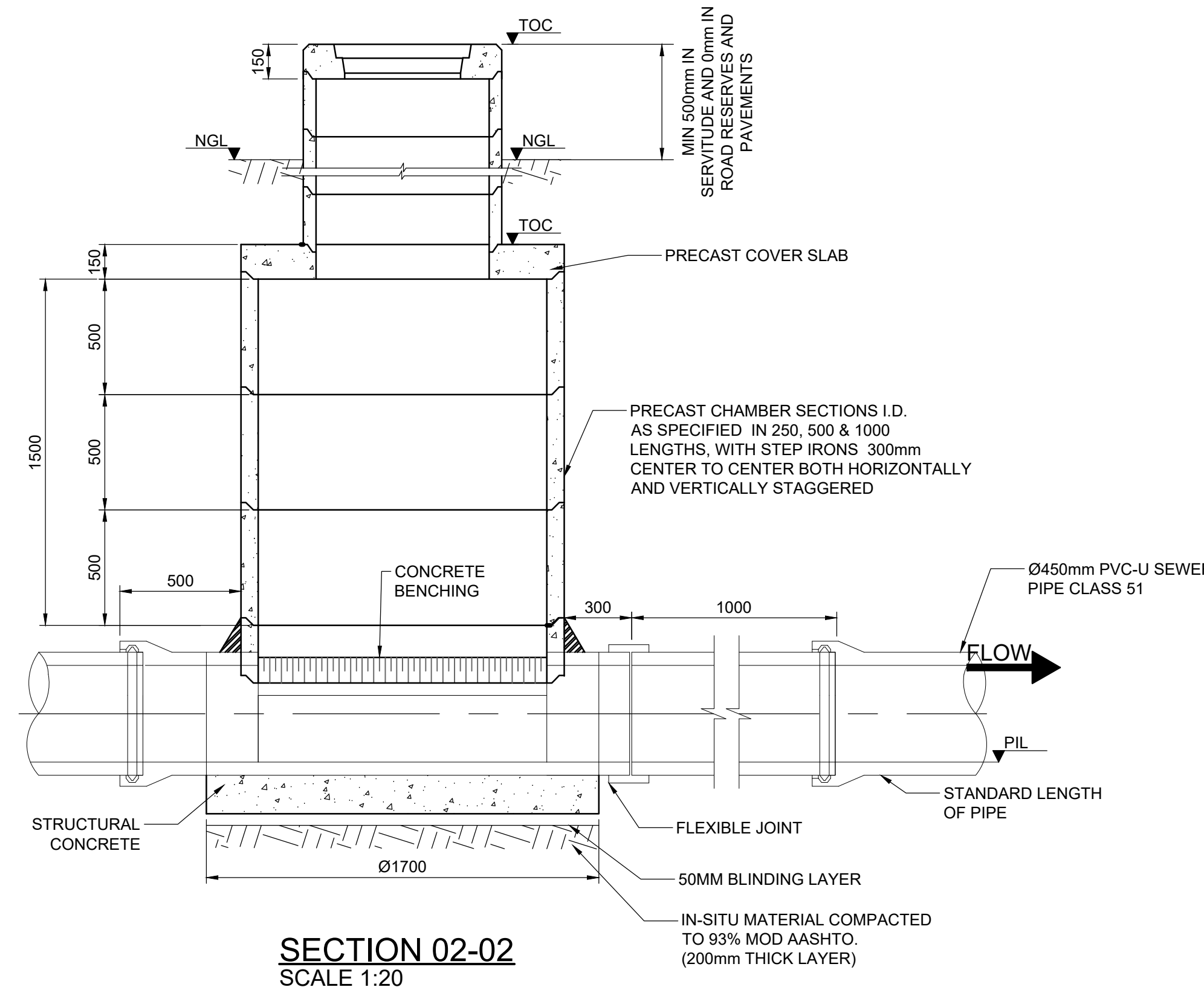
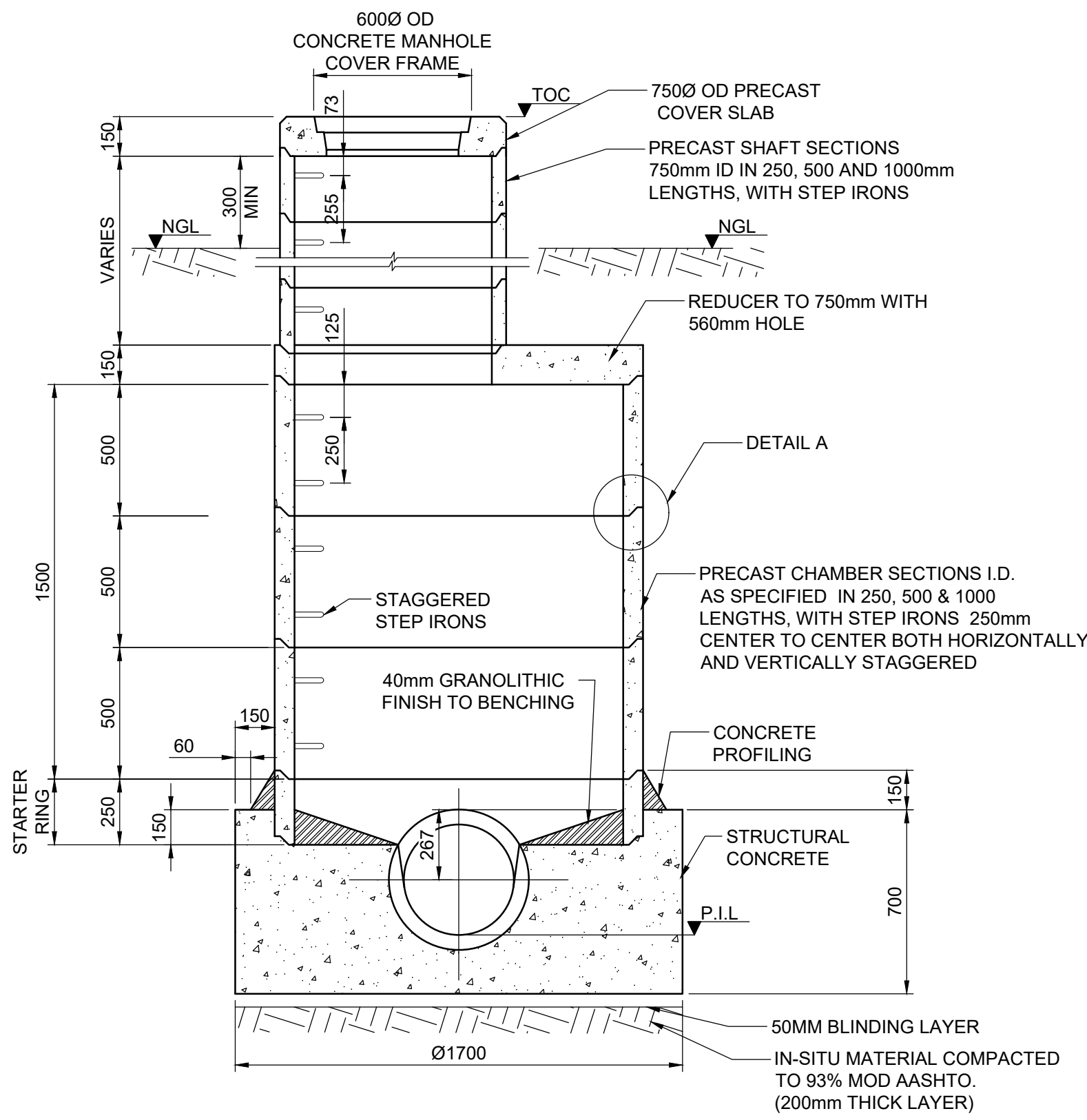

**FOR TENDER PURPOSES ONLY**

DESIGNED	N. NDLOVU	DRAWN	D. GLOY	CHECKED	B. SEAKE	DATE	14/07/2021	NATURE OF REVISION	NO.
	NAME		NAME		DATE				
INTERNATIONAL BUSINESS GATEWAY OFFICE PARK		CNR PIONEER AVENUE AND ELIZABETH MIDRIDGE PARK		COPYRIGHT RESERVED ©		E-MAIL: info@zimile.co.za		PROJECT PHASE	
APPROVED:		CLIENT:		APPROVED:		PROJECT:		PRELIMINARY	
B. SEAKE		HARIB GWALA DISTRICT MUNICIPALITY		B. SEAKE		UMZIMKHULU BULK SEWER		TENDER	
FOR ZIMILE CONSULTING ENGINEERS				DESIGNATION: TECHNICAL MANAGER		TITLE:		CONSTRUCTION	
DATE				DATE		450mmØ PIPE TYPE 2 MANHOLE DETAILS		AS-BUILT	
SIGNATURE				SIGNATURE				DATE: JULY 2020	
								SCALE: AS SHOWN	
								DRAWING No. J000096	
								REVISION	
								WT DE 205 A	
								A1	



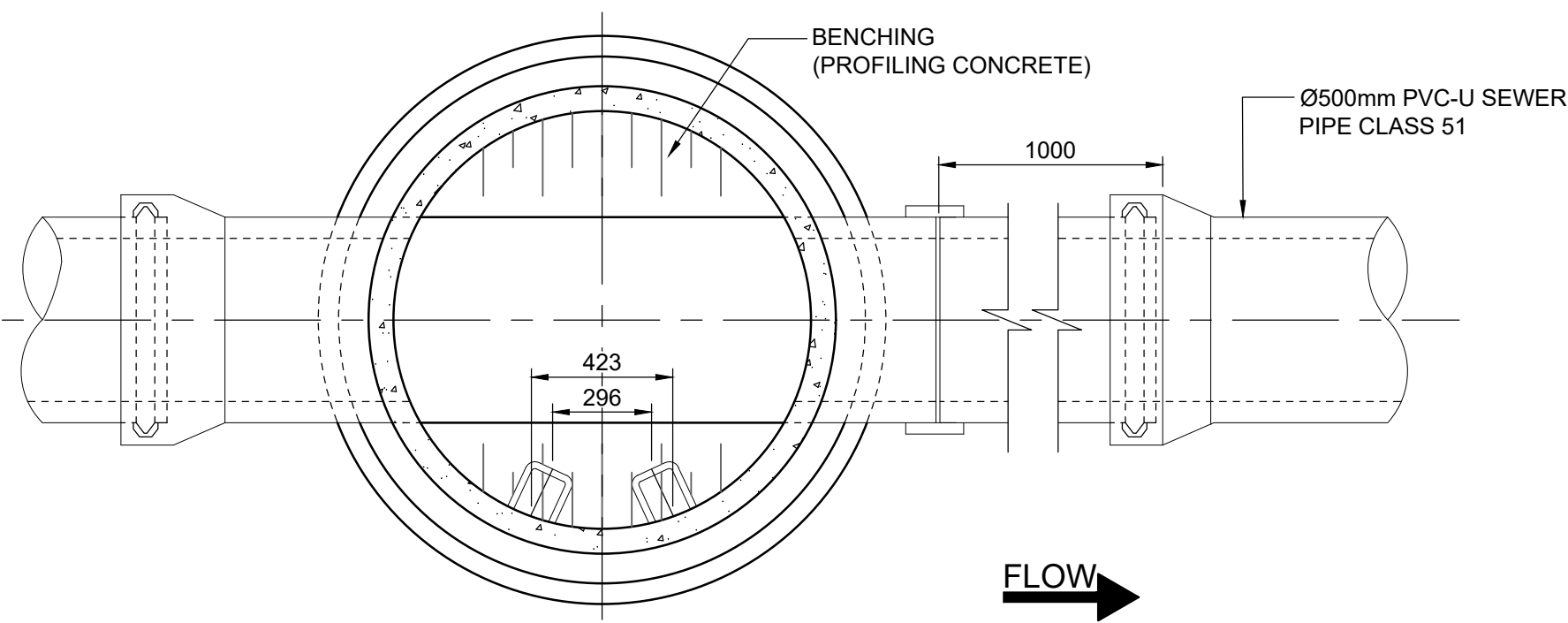

PLAN  
SCALE 1:20

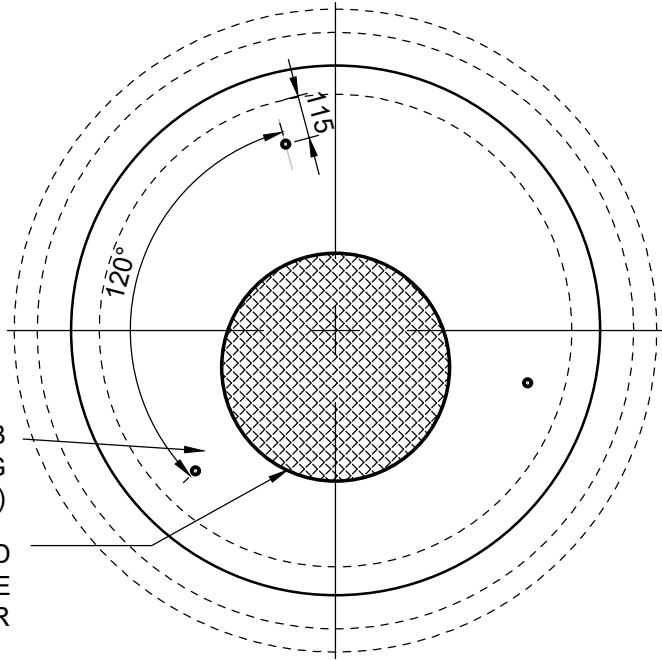

MANHOLE COVER  
SCALE 1:20

STRUCTURE LIST-NORTHERN OUTFALL SEWER				
MH. NAME	Y	X	RIM ELEVATION	RIM TO SUMP DEPTH
MH58	-90 488.428	3 349 184.357	726.511	6.753
MH59	-90 541.314	3 349 161.132	726.787	7.384
MH60	-90 573.024	3 349 189.680	727.074	7.933
MH61	-90 574.909	3 349 231.010	726.616	7.730
MH62	-90 577.831	3 349 246.320	726.515	7.725
MH63	-90 579.249	3 349 277.845	726.558	7.962
MH64	-90 578.066	3 349 296.407	726.383	7.901
MH65	-90 625.159	3 349 290.385	726.365	8.176
MH66	-90 634.602	3 349 310.606	726.219	8.167
MH67	-90 636.737	3 349 331.294	726.069	8.145
MH68	-90 649.982	3 349 410.095	725.681	8.314
MH69	-90 663.635	3 349 491.326	725.259	8.333
MH70	-90 676.894	3 349 498.781	725.157	8.326
MH71	-90 693.875	3 349 599.782	724.729	8.527
MH72	-90 707.139	3 349 678.675	723.816	8.259
MH73	-90 723.162	3 349 773.974	722.034	6.919
MH74	-90 710.468	3 349 796.593	723.238	8.286
MH77	-90 656.735	3 349 494.599	725.270	1.487

PIPE LIST-NORTHERN OUTFALL SEWER				
PIPE NAME	START LEVEL	END LEVEL	Dis. (m)	Diam. (mm)
P58	719.757	719.403	56.515	500 mm CLASS 51
P59	719.403	719.140	41.422	500 mm CLASS 51
P60	719.140	718.886	40.127	500 mm CLASS 51
P61	718.886	718.790	14.340	500 mm CLASS 51
P62	718.790	718.596	30.311	500 mm CLASS 51
P63	718.596	718.481	17.353	500 mm CLASS 51
P64	718.481	718.189	46.230	500 mm CLASS 51
P65	718.189	718.052	21.071	500 mm CLASS 51
P66	718.052	717.924	19.550	500 mm CLASS 51
P67	717.924	717.432	78.661	500 mm CLASS 51
P68	717.432	716.925	81.125	500 mm CLASS 51
P69	716.925	716.832	13.965	500 mm CLASS 51
P70	716.832	716.202	101.173	500 mm CLASS 51
P71	716.202	715.710	78.755	500 mm CLASS 51
P72	715.709	715.115	95.391	500 mm CLASS 51
P73	715.115	714.952	25.016	500 mm CLASS 51
P77	723.784	723.720	6.391	500 mm CLASS 51

**CONCRETE:**

ALL CONCRETE WORK SHALL COMPLY WITH THE REQUIREMENTS OF SANS 1200 G.

STRIPPING TIMES OF FORMWORK AND PROPPING SHALL BE IN ACCORDANCE WITH SANS 1200G.

PROVIDE A 25x25mm CHAMFER TO ALL EXPOSED CORNERS.

ALL EXPOSED CONCRETE WORK TO BE OFF-SHUTTER FINISH.

CEMENT EXTENDERS (eg. FLY ASH) TO BE USED ONLY IF APPROVED BY THE ENGINEER.

ALL EXPOSED SLAB EDGES TO HAVE 40mm COVER.

ALL INSIDE LEVELS REFER TO CONCRETE AND NOT TO FINISHED FLOOR EXCEPT WHERE OTHERWISE INDICATED.

THE CONTRACTOR SHALL PROVIDE ALL POURING PROCEDURES, CONSTRUCTION METHODS AND POSITIONS OF CONSTRUCTION JOINTS PRIOR TO COMMENCEMENT OF PROJECT.

THE GRADES OF CONCRETE SHALL BE AS FOLLOWS:  
ALL STRUCTURAL CONCRETE CLASS 30/19  
SURFACE BEDS CLASS 30/19  
BLINDING LAYERS CLASS 10/19  
MASS CONCRETE CLASS 10/19  
PROFILING CONCRETE CLASS 30/19

CONCRETE SHALL BE CURED IN ACCORDANCE WITH SANS 1200 G.

TEMPLATES SHALL BE USED TO SET H.D. BOLTS IF POCKETS ARE NOT PROVIDED.

PANELS BETWEEN CONSTRUCTION JOINTS TO BE CAST CONSECUTIVELY

BEFORE CONCRETING TAKES PLACE ALL FOUNDATIONS ARE TO BE INSPECTED ON SITE BY THE GEOTECHNICAL ENGINEER.

THE FOUNDATION LEVELS INDICATED ARE APPROXIMATE ONLY. FINAL FOUNDING LEVELS ARE TO BE DETERMINED ON SITE BY THE GEOTECHNICAL ENGINEER.

THE DIFFERENCE BETWEEN FINAL FOUNDING LEVELS AND BOTTOM OF FOUNDATIONS SHOWN TO BE MADE UP WITH 10 MPa MASS CONCRETE.

UNLESS NOTED ALL FOUNDATIONS TO HAVE A MINIMUM OF 50mm THICK 10MPa CONCRETE BLINDING LAYER.

DURING CONSTRUCTION ALL EXCAVATIONS SHALL BE KEPT FREE OF WATER.

ALL INTERNAL AND EXPOSED CONCRETE SHALL BE SHUTTERED. IF EXTERNAL CONCRETE IS NOT SHUTTERED, AN ADDITIONAL 25mm OF CONCRETE SHALL BE ADDED TO CREATE COVER OF 75mm.

THE BOTTOM OF ALL FOUNDATIONS ARE TO BE LEVEL. IF REQUIRED, STEPS MAY BE FORMED IN ACCORDANCE WITH SANS 10400, WITH THE APPROVAL OF THE ENGINEER.

TOP OF THE EXCAVATIONS IN CUT SHALL BE RIPPED & SCARIFIED FOR 150mm AND SHALL BE COMPACTED TO 95% MOD AASHTO AT OPTIMUM MOISTURE CONTENT.

ALL LEVELS FOR FOUNDATIONS SHALL BE CHECKED FOR ITS CORRECTNESS ON SITE.

**GENERAL NOTES:**

- 1) SPACER SLABS FOR HEAVY DUTY TYPE 2A & I MANHOLE COVERS AND FRAMES TO BE 900 x 900 x 75mm WITH 560Ø OPENING.
- 2) SPACER SLABS FOR MEDIUM DUTY TYPE 4 MANHOLE COVERS AND FRAMES TO BE 800 Ø x 75mm THICK WITH 560Ø OPENING.
- 3) ADAPTOR SLABS FOR HEAVY DUTY TYPE 2A & I MANHOLE COVERS AND FRAMES TO BE 900 x 900 x 125mm WITH 560Ø OPENING.
- 4) ADAPTOR SLABS FOR MEDIUM DUTY TYPE 4 MANHOLE COVERS AND FRAMES TO BE 860Ø WITH 560Ø OPENING.
- 5) OMIT ADAPTOR SLAB ON SHALLOW MANHOLES WHERE SHAFT SECTIONS ARE NOT REQUIRED.

**BRINK WORK NOTES:**

- 1) ALL PIPE CONNECTIONS TO MANHOLES TO HAVE FLEXIBLE JOINT AS PER DETAIL A.
- 2) BRICKWORK TO BE 220mm IN WIDTH (DOUBLE FACEBRICK WALLS).
- 3) ALL BRICKWORK TO BE PLASTERED INTERNALLY AND EXTERNALLY WITH 13mm 1:3 CEMENT MORTAR.
- 4) STEP IRONS TO BE PLACED AT 250mm CENTRES, STAGGERED LEFT AND RIGHT.

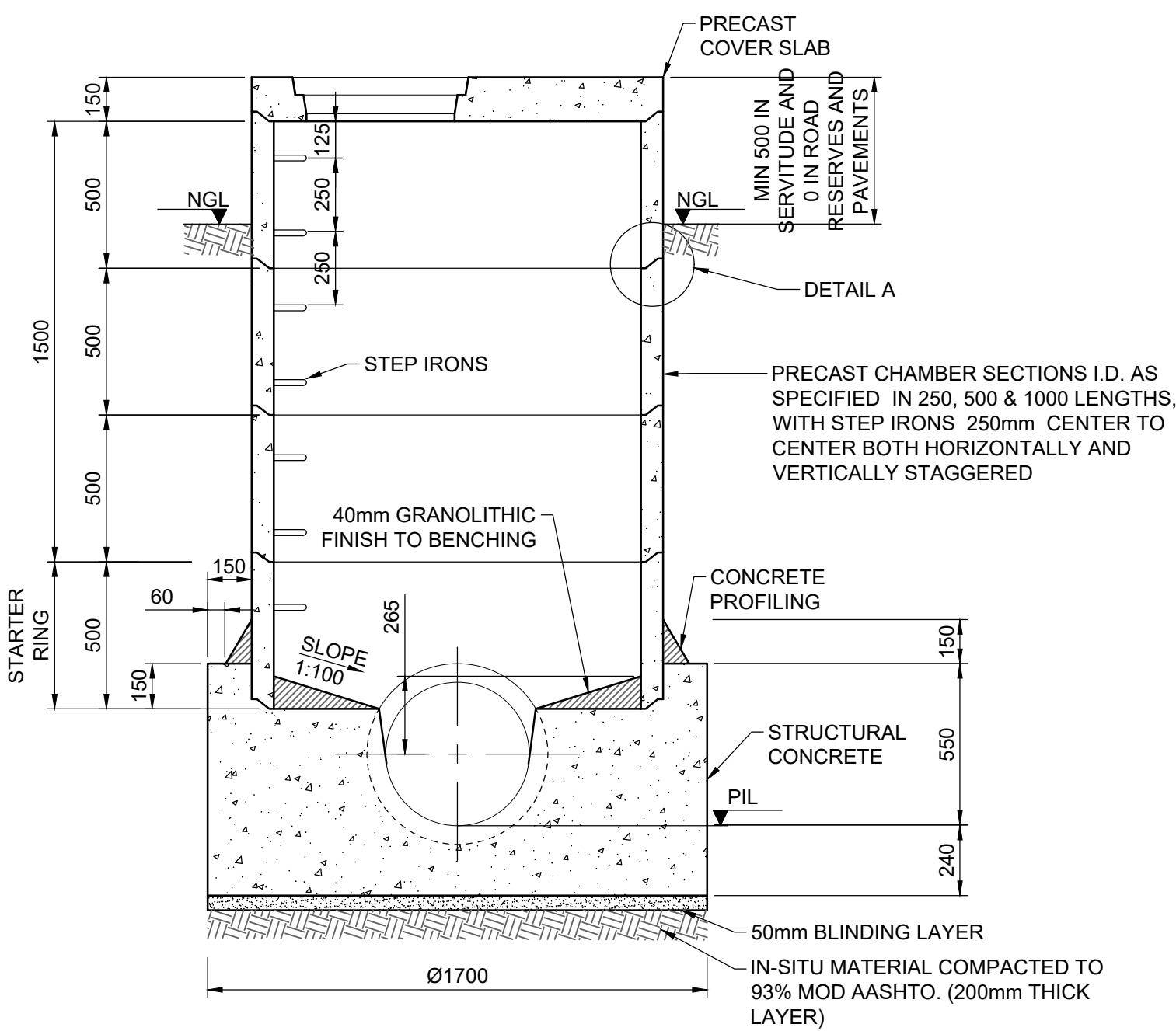

SECTION 01-01  
SCALE 1:20

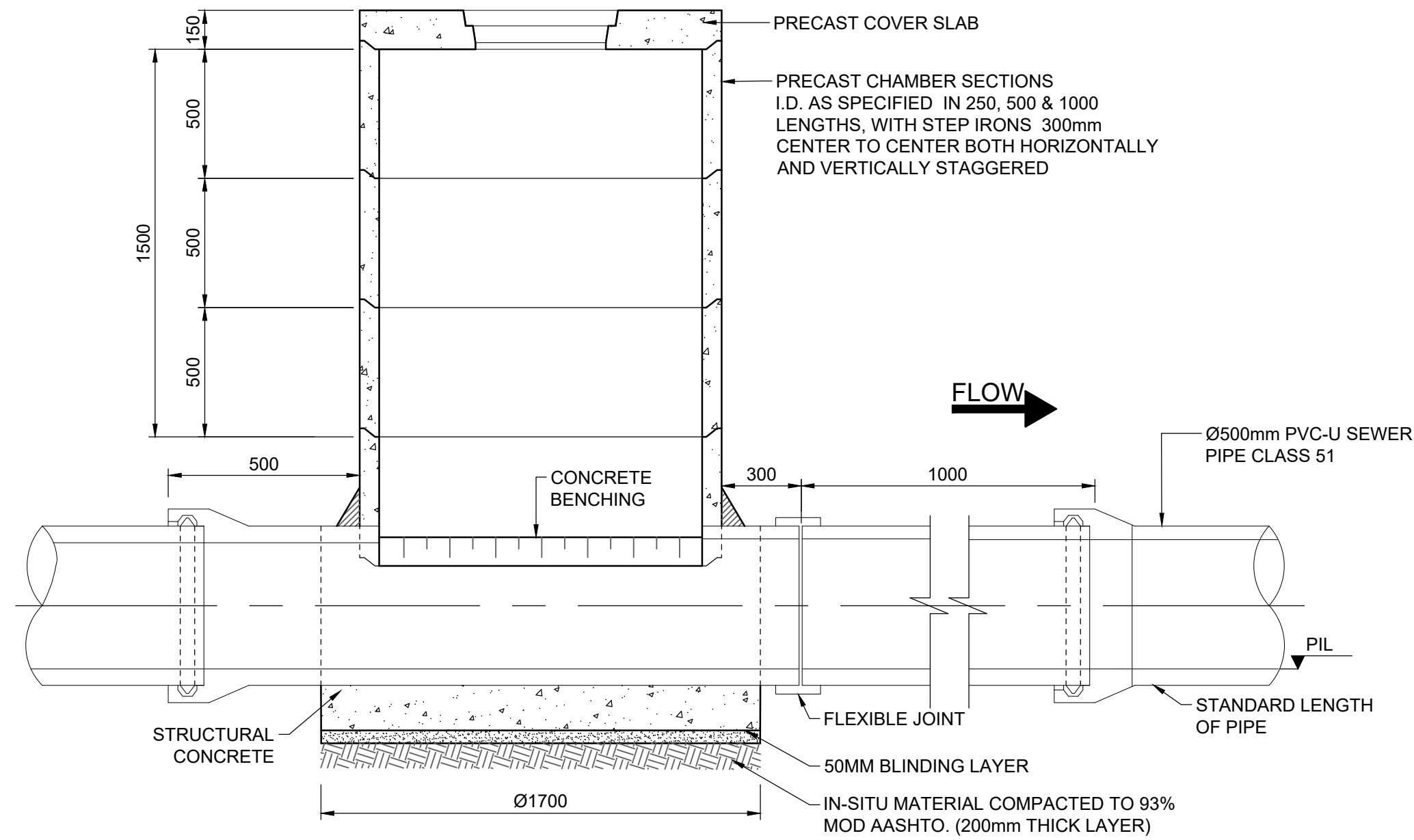

SECTION 02-02  
SCALE 1:20

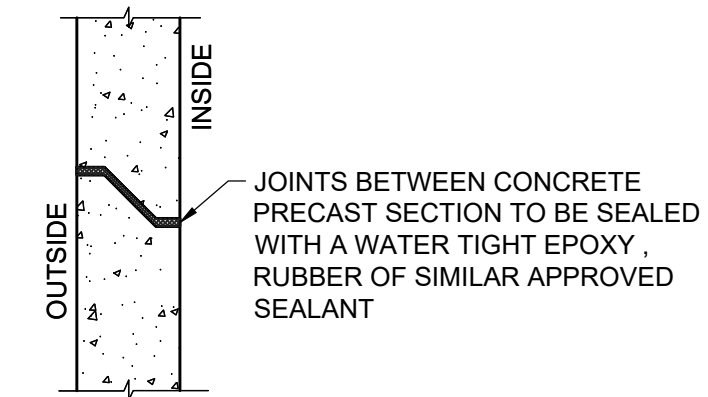

DETAIL A  
SCALE 1:5

SECTION	
07	SECTION NUMBER
3	SHEET NUMBER

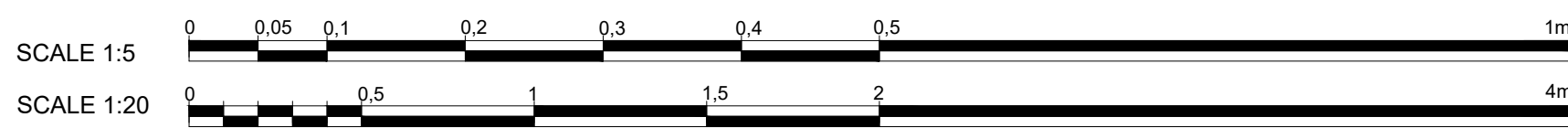

**FOR TENDER PURPOSES ONLY**

DESIGNED N. NDLOVU	DRAWN N. STUURMAN	CHECKED B. SEAKE	 INTERNATIONAL BUSINESS GATEWAY OFFICE PARK CNR PIONEER AVENUE AND ELIZABETH MIDRIDGE PARK TEL: (011) 466-8576 FAX: (011) 466-8813 E-MAIL: info@zimile.co.za COPYRIGHT RESERVED ©	SCALE BAR:  70mm ON ORIGINAL DRAWING	CLIENT:  MUNICIPALITY	APPROVED: B. SEAKE FOR ZIMILE CONSULTING ENGINEERS DESIGNATION: TECHNICAL MANAGER DATE: _____ SIGNATURE: _____	PROJECT: UMZIMKHULU BULK SEWER TITLE: 500mmØ PIPE TYPE 1 MANHOLE DETAILS	PROJECT PHASE						
								PRELIMINARY	TENDER	CONSTRUCTION	AS-BUILT			
ISSUED FOR TENDER		14/07/2021		DATE: JULY 2020		SCALE: AS SHOWN		DRAWING No. J000096		WT	DE	206	REVISION	A
NATURE OF REVISION		DATE		CAD FILENAME		21\Current Projects\WATER DEPARTMENT\200096 - Umzimkhulu Bulk Sewer\4. Procurement Stage1 - Tender Drawings\01 Water\01 Working Drawings\000096-WT-CC-CIP_Pack_000mm Dia Pipe Type 1 Sewer Manhole Details.dwg		SIZE		A1		Desena21 07 2021		



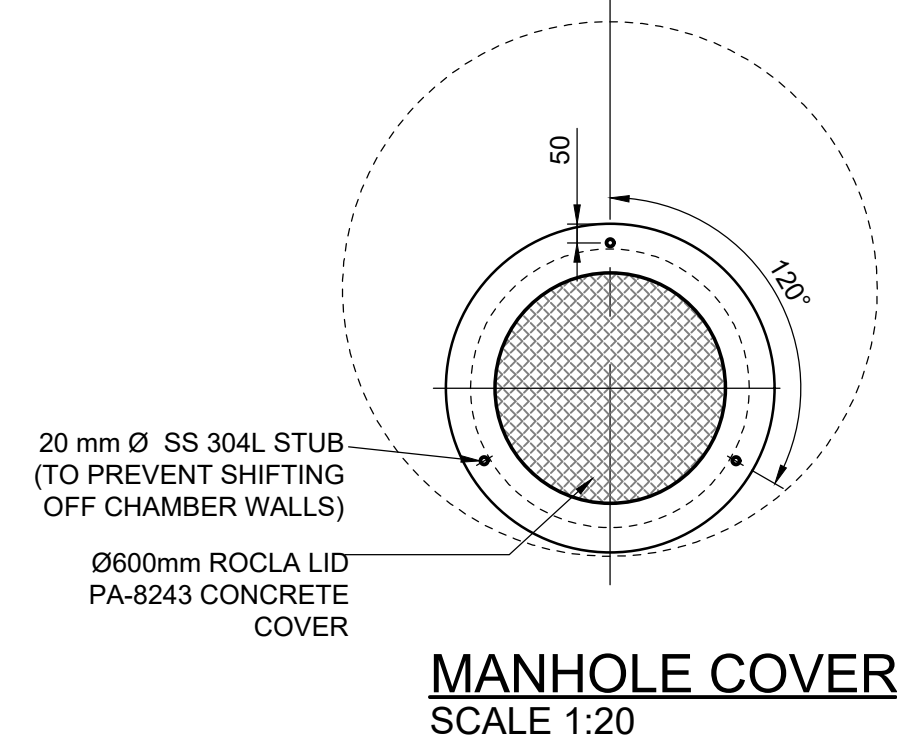
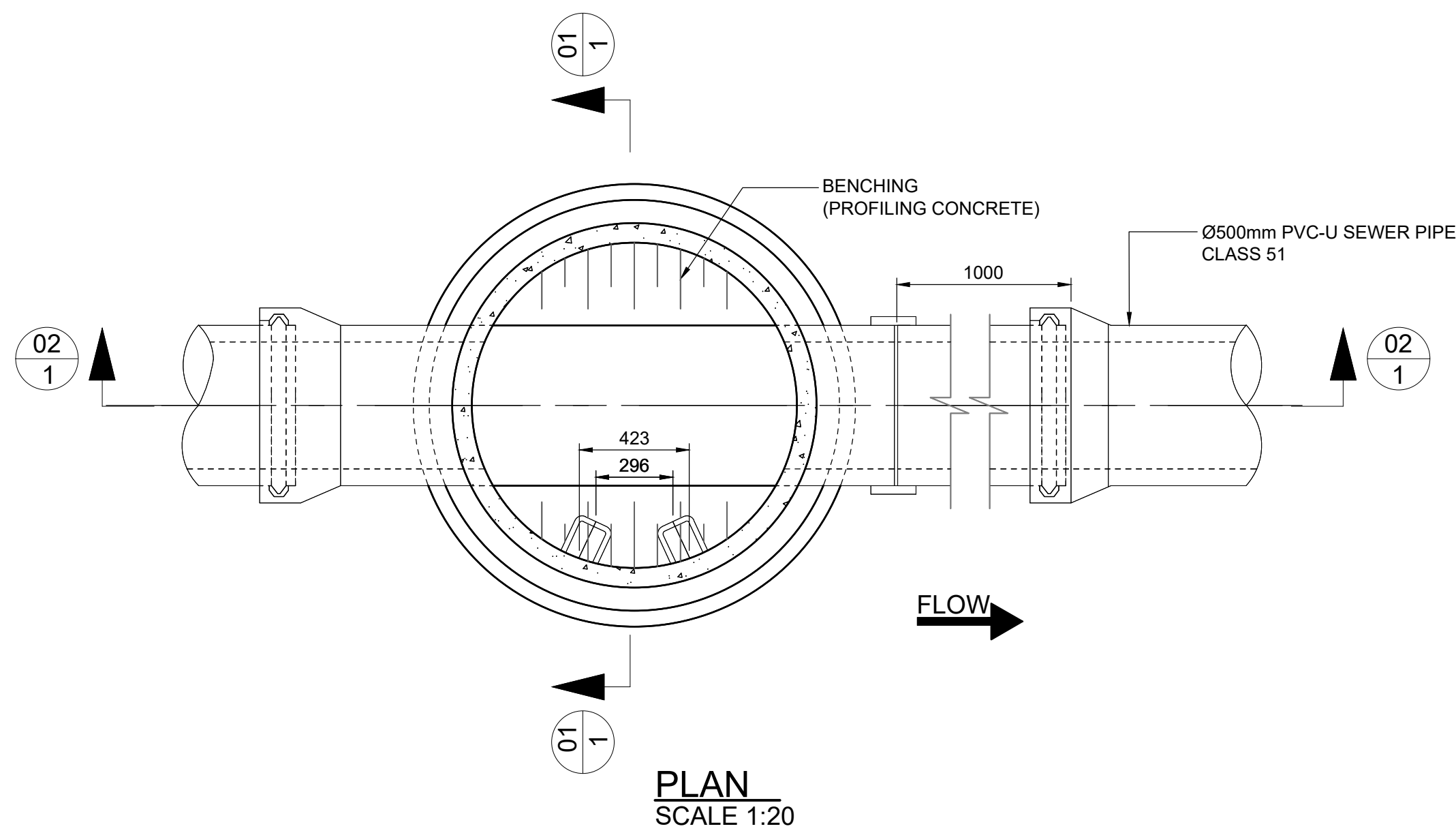

STRUCTURE LIST-NORTHERN OUTFALL SEWER				
MH. NAME	Y	X	INVERT LEVEL	DEPTH TO SUMP
MH58	-90 488.428	3 349 184.357	726.511	6.753
MH59	-90 541.314	3 349 161.132	726.787	7.384
MH60	-90 573.024	3 349 189.680	727.074	7.933
MH61	-90 574.909	3 349 231.010	726.616	7.730
MH62	-90 577.831	3 349 246.320	726.515	7.725
MH63	-90 579.249	3 349 277.845	726.558	7.962
MH64	-90 578.066	3 349 296.407	726.383	7.901
MH65	-90 625.159	3 349 290.385	726.365	8.176
MH66	-90 634.602	3 349 310.606	726.219	8.167
MH67	-90 636.737	3 349 331.294	726.069	8.145
MH68	-90 649.982	3 349 410.095	725.681	8.314
MH69	-90 663.635	3 349 491.326	725.259	8.333
MH70	-90 676.894	3 349 498.781	725.157	8.326
MH71	-90 693.875	3 349 599.782	724.729	8.527
MH72	-90 707.139	3 349 678.675	723.816	8.259
MH73	-90 723.162	3 349 773.974	722.034	6.919
MH74	-90 710.468	3 349 796.593	723.238	8.286
MH77	-90 656.735	3 349 494.599	725.270	1.487

PIPE LIST-NORTHERN OUTFALL SEWER				
PIPE NAME	START LEVEL	END LEVEL	Dis. (m)	Diam. (mm)
P58	719.757	719.403	56.515	500 mm CLASS 51
P59	719.403	719.140	41.422	500 mm CLASS 51
P60	719.140	718.886	40.127	500 mm CLASS 51
P61	718.886	718.790	14.340	500 mm CLASS 51
P62	718.790	718.596	30.311	500 mm CLASS 51
P63	718.596	718.481	17.353	500 mm CLASS 51
P64	718.481	718.189	46.230	500 mm CLASS 51
P65	718.189	718.052	21.071	500 mm CLASS 51
P66	718.052	717.924	19.550	500 mm CLASS 51
P67	717.924	717.432	78.661	500 mm CLASS 51
P68	717.432	716.925	81.125	500 mm CLASS 51
P69	716.925	716.832	13.965	500 mm CLASS 51
P70	716.832	716.202	101.173	500 mm CLASS 51
P71	716.202	715.710	78.755	500 mm CLASS 51
P72	715.709	715.115	95.391	500 mm CLASS 51
P73	715.115	714.952	25.016	500 mm CLASS 51
P77	723.784	723.720	6.391	500 mm CLASS 51

**CONCRETE:**

ALL CONCRETE WORK SHALL COMPLY WITH THE REQUIREMENTS OF SANS 1200 G.

STRIPPING TIMES OF FORMWORK AND PROPPING SHALL BE IN ACCORDANCE WITH SANS 1200G.

PROVIDE A 25x25mm CHAMFER TO ALL EXPOSED CORNERS.

ALL EXPOSED CONCRETE WORK TO BE OFF - SHUTTER FINISH

CEMENT EXTENDERS (eg. FLY ASH) TO BE USED ONLY IF APPROVED BY THE ENGINEER.

ALL EXPOSED SLAB EDGES TO HAVE 40mm COVER.

ALL INSIDE LEVELS REFER TO CONCRETE AND NOT TO FINISHED FLOOR EXCEPT WHERE OTHERWISE INDICATED.

THE CONTRACTOR SHALL PROVIDE ALL POURING PROCEDURES, CONSTRUCTION METHODS AND POSITIONS OF CONSTRUCTION JOINTS PRIOR TO COMMENCEMENT OF PROJECT.

THE GRADES OF CONCRETE SHALL BE AS FOLLOWS:  
 ALL STRUCTURAL CONCRETE CLASS 30/19  
 SURFACE BEDS CLASS 30/19  
 BLINDING LAYERS CLASS 10/19  
 MASS CONCRETE CLASS 10/19  
 PROFILING CONCRETE CLASS 30/19

CONCRETE SHALL BE CURED IN ACCORDANCE WITH SANS 1200 G.

TEMPLATES SHALL BE USED TO SET H.D.BOLTS IF POCKETS ARE NOT PROVIDED.

PANELS BETWEEN CONSTRUCTION JOINTS TO BE CAST CONSECUTIVELY

BEFORE CONCRETING TAKES PLACE ALL FOUNDATIONS ARE TO BE INSPECTED ON SITE BY THE GEOTECHNICAL ENGINEER.

THE FOUNDATION LEVELS INDICATED ARE APPROXIMATE ONLY. FINAL FOUNDING LEVELS ARE TO BE DETERMINED ON SITE BY THE GEOTECHNICAL ENGINEER.

THE DIFFERENCE BETWEEN FINAL FOUNDING LEVELS AND BOTTOM OF FOUNDATIONS SHOWN TO BE MADE UP WITH 10 MPa MASS CONCRETE.

UNLESS NOTED ALL FOUNDATIONS TO HAVE A MINIMUM OF 50mm THICK 10MPa CONCRETE BLINDING LAYER.

DURING CONSTRUCTION ALL EXCAVATIONS SHALL BE KEPT FREE OF WATER.

ALL INTERNAL AND EXPOSED CONCRETE SHALL BE SHUTTERED. IF EXTERNAL CONCRETE IS NOT SHUTTERED, AN ADDITIONAL 25mm OF CONCRETE SHALL BE ADDED TO CREATE COVER OF 75mm.

THE BOTTOM OF ALL FOUNDATIONS ARE TO BE LEVEL. IF REQUIRED, STEPS MAY BE FORMED IN ACCORDANCE WITH SANS 10400, WITH THE APPROVAL OF THE ENGINEER.

TOP OF THE EXCAVATIONS IN CUT SHALL BE RIPPED & SCARIFIED FOR 150mm AND SHALL BE COMPACTED TO 95% MOD AASHTO AT OPTIMUM MOISTURE CONTENT.

ALL LEVELS FOR FOUNDATIONS SHALL BE CHECKED FOR ITS CORRECTNESS ON SITE.

**GENERAL NOTES:**

- 1) SPACER SLABS FOR HEAVY DUTY TYPE 2A & I MANHOLE COVERS AND FRAMES TO BE 900 x 900 x 75mm WITH 560Ø OPENING.
- 2) SPACER SLABS FOR MEDIUM DUTY TYPE 4 MANHOLE COVERS AND FRAMES TO BE 800 Ø x 75mm THICK WITH 560Ø OPENING.
- 3) ADAPTOR SLABS FOR HEAVY DUTY TYPE 2A & I MANHOLE COVERS AND FRAMES TO BE 900 x 900 x 125mm WITH 560Ø OPENING.
- 4) ADAPTOR SLABS FOR MEDIUM DUTY TYPE 4 MANHOLE COVERS AND FRAMES TO BE 860Ø WITH 560Ø OPENING.
- 5) OMIT ADAPTOR SLAB ON SHALLOW MANHOLES WHERE SHAFT SECTIONS ARE NOT REQUIRED.

**BRINK WORK NOTES:**

- 1) ALL PIPE CONNECTIONS TO MANHOLES TO HAVE FLEXIBLE JOINT AS PER DETAIL A.
- 2) BRICKWORK TO BE 220mm IN WIDTH (DOUBLE FACEBRICK WALLS).
- 3) ALL BRICKWORK TO BE PLASTERED INTERNALLY AND EXTERNALLY WITH 13mm 1:3 CEMENT MORTAR.
- 4) STEP IRONS TO BE PLACED AT 250mm CENTRES, STAGGERED LEFT AND RIGHT.

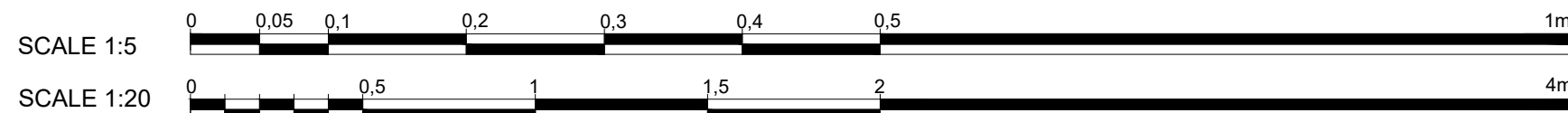
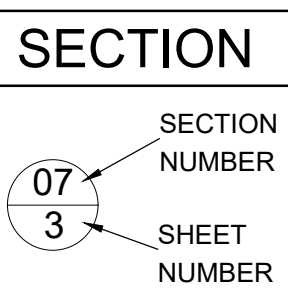
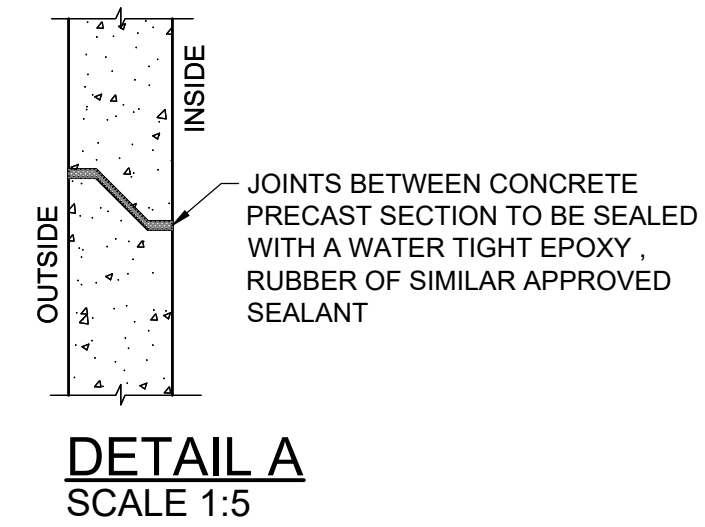
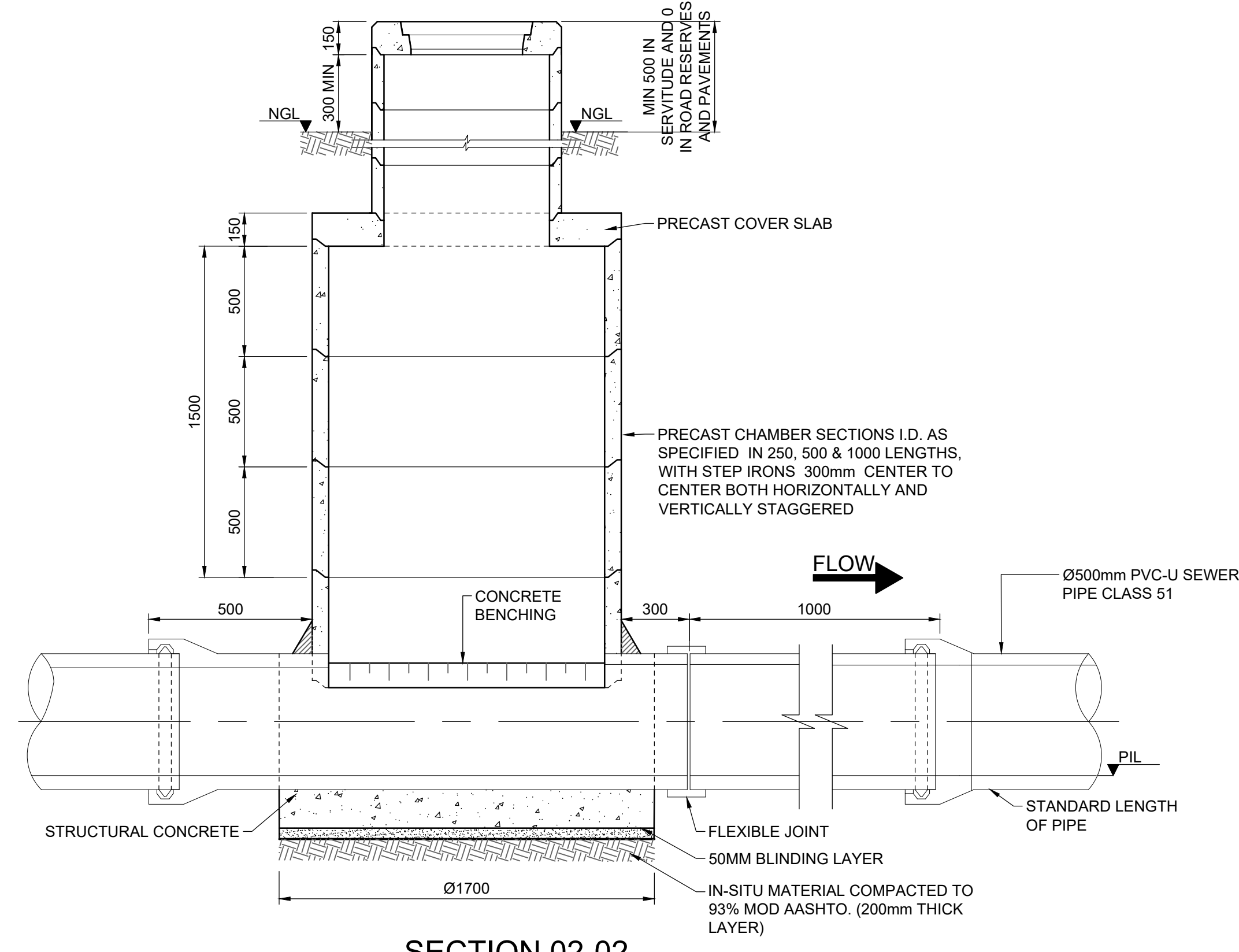
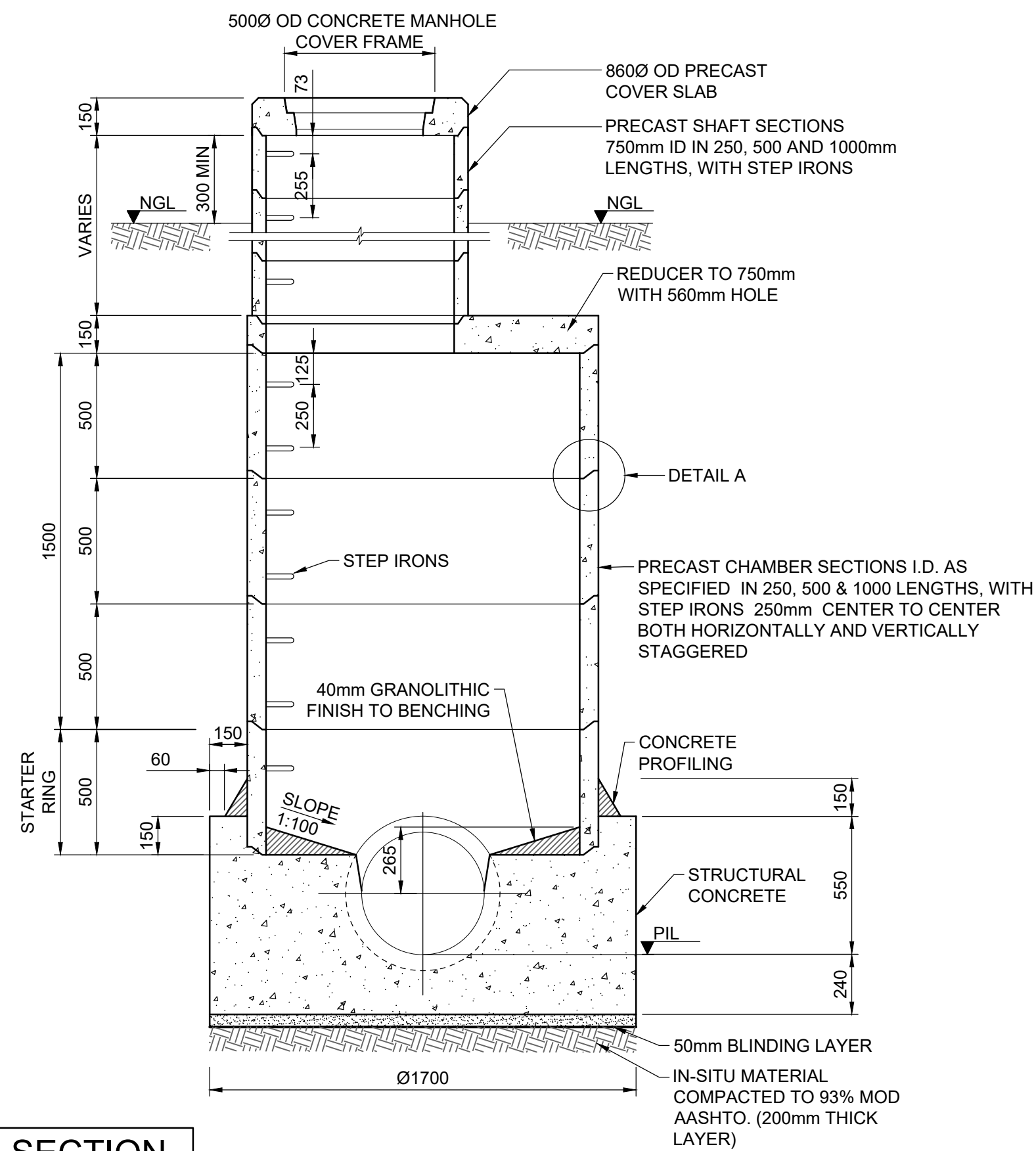

**FOR TENDER PURPOSES ONLY**

NO.	NATURE OF REVISION	DATE
A	ISSUED FOR TENDER	14/07/2021

DESIGNED	N. NDLOVU
DRAWN	N. STUURMAN
CHECKED	B. SEAKE

**ZIMILE Consulting Engineers**  
 INTERNATIONAL BUSINESS GATEWAY OFFICE PARK  
 CNR PIONEER AVENUE AND ELIZABETH MIDRIDGE PARK  
 TEL: (011) 466 - 8576  
 FAX: (011) 466 - 8813  
 E-MAIL: info@zimile.co.za  
 COPYRIGHT RESERVED ©

SCALE BAR:  
 0 70  
 70mm ON ORIGINAL DRAWING

CLIENT:

APPROVED:  
 B. SEAKE  
 FOR ZIMILE CONSULTING ENGINEERS  
 DESIGNATION: TECHNICAL MANAGER  
 DATE: \_\_\_\_\_ SIGNATURE: \_\_\_\_\_

PROJECT:  
 UMZIMKHULU BULK SEWER  
 TITLE:  
 500mmØ PIPE TYPE 2 MANHOLE DETAILS

PROJECT PHASE			
PRELIMINARY	TENDER	CONSTRUCTION	AS-BUILT
DATE:	JULY 2020	SCALE:	AS SHOWN
DRAWING No.	J000096	WT	DE 207
CAD FILENAME	Y:\Current Projects\WATER DEPARTMENT\J000096 - Umzimkhulu Bulk Sewer Procurement Stage1 - Tender Drawings\02 - Manhole Working Drawings\J000096-WT-DE-207_RevA_500mm Dia Pipe Type 2 Sewer Manhole Details.dwg		REVISION
			A
			A1